

ON SALE JULY 26th

SEPTEMBER ISSUE ON SALE  
AUGUST 22nd

|24| Grundig Yacht Boy 220

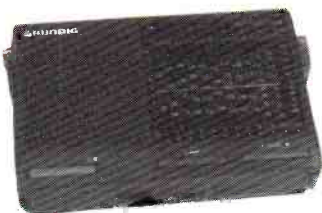

**Cover** Small short wave receivers, such as the Grundig Yacht Boy 220, are ideal to take abroad — if only to let you listen to the BBC World Service.

EDITOR: Dick Ganderton, C.Eng., MIEE, G8V FH  
ART EDITOR: Steve Hunt  
EDITORIAL ASSISTANT: Sharon George  
TECHNICAL ARTIST: Rob Mackie

**Editorial & Advertising**

Enefco House, The Quay,  
Poole, Dorset BH15 1PP  
Poole (0202) 678558 (24hrs)  
FAX (0202) 666244  
Prestel MBX 202671191

ADVERTISEMENT DEPARTMENT  
ADVERTISEMENT MANAGER  
Roger Hall G4TNT  
(071-731 6222)  
Dave Gadsden G4NXV  
ADVERTISEMENT PRODUCTION  
Marcia Brogan

## © COPYRIGHT

PW Publishing Limited 1990  
Copyright in all drawings, photographs and articles published in *Short Wave Magazine* is fully protected and reproduction or imitation in whole or in part is expressly forbidden. All reasonable precautions are taken by *Short Wave Magazine* to ensure that the advice and data given to our readers is reliable. We cannot however guarantee it and we cannot accept legal responsibility for it. Prices are those current as we go to press.

## CONTENTS

# Short Wave Magazine

Cirkit Satellite System Modifications	10	<i>Peter Rouse GU1DKD</i>
Please QSL SWM Review	16	<i>P. E. W. Allely GW3KJW</i>
Grundig Yacht Boy 220	24	<i>John Bird</i>
Using a Solar Radio Telescope Part 4	26	<i>Ron Ham</i>
RTTY Data Decoder Program	29	<i>Ian Wraith</i>
An Easily Built 16-30MHz Converter for the R210 Receiver Part 2	30	<i>Bryan Robertson G4POL</i>
DXpedition to Ecuador	33	<i>Two Weeks DXing in Ecuador</i>

## REGULARS

First Word	2	<i>Editorial</i>
A Word in Edgeways	2	<i>Your Letters</i>
What's New	4	<i>Latest News &amp; Products</i>
Grassroots	6	<i>Club News</i>
Trading Post	7	<i>Readers' Adverts</i>
Rallies	12	<i>Where to Go</i>
Scanning	14	<i>For the Scanning Enthusiast</i>
Subscriptions	17	<i>Save Some Money</i>
Airband	20	<i>Aeronautical Radio News</i>
Services	25	<i>Important Information</i>
SWM PCB Service	26	<i>PCBs for SWM Projects</i>
Starting Out	34	<i>For the Beginner</i>
RADIOLINE	48	<i>News &amp; Info Hotline</i>
Advertisers' Index	56	<i>Find that Advert</i>
Bookcase	58	<i>Book Reviews</i>
Book Service	59	<i>Order Your Technical Books</i>

## SEEN &amp; HEARD

Amateur Bands Round-Up	38	<i>Paul Essery GW3KFE</i>
Decode	40	<i>Mike Richards G4WNC</i>
Info in Orbit	42	<i>Lawrence Harris</i>
Band II DX	44	<i>Ron Ham</i>
Television	46	<i>Ron Ham</i>
Long Medium & Short	49	<i>Brian Oddy G3FEX</i>
LW Maritime Radio Beacons	57	<i>Brian Oddy G3FEX</i>



# FIRST WORD

Have you thought about joining the SWM/HCJB DXpedition to Ecuador next May?

It should be a great opportunity to not only have a fantastic holiday but also to be able to DX those stations which are out of reach from the UK.

Several readers have asked what there will be for their wives to do. I can assure you that there will be plenty of opportunities for all the normal tourist activities as well as the radio orientated ones. We are hoping that any licensed amateurs who travel to Quito on the DXpedition will be able to operate, if they wish of course, from the exotic locations which the party will visit.

Places are strictly limited so you would be well advised to reserve your place now.



The 'Word in Edgeways' column this month is one of the largest that I can remember. George Millmore certainly stirred up a hornets' nest with his letter regarding the usefulness of Morse in the modern world.

I have been able to print only a selection from readers - some of them were long enough to make complete articles in themselves!

Do you ring *RadioLine* each week. *RadioLine* has now been running for over six months and although it obviously has its band of followers I would like to see more readers using the service.

I am interested to hear from you so that I can ensure that the content of the weekly message is what you want to hear. Without your feedback I am working in the dark when I write the script.

## A WORD IN EDGEWAYS

**IF YOU HAVE ANY POINTS OF VIEW THAT YOU WANT TO AIR PLEASE WRITE TO THE EDITOR. IF YOUR LETTER IS USED YOU WILL RECEIVE A £5 VOUCHER TO SPEND ON ANY SWM SERVICE.**

The Editor reserves the right to shorten any letters for publication but will try not to alter their sense. Letters must be original and not have been submitted to other magazines. The views expressed in letters published in this magazine are not necessarily those of Short Wave Magazine.

**Dear Sir**

This is my last letter to the press. I feel I must make some comment reference the letter from Mr Millmore of the Isle of Wight, in June SWM. He says "very few c.w. transmissions between 150kHz and 30MHz. What kind of world is he in as regards radio? I left school at 14, got a job as a telegraph operator at 15. I was at sea a good many years. I am an avid listener of c.w. whenever or whoever it's from, shipping particularly of interest. CW is universal and has no limits as to range. Every country has its many stations in communicating to and from ships. I have heard ships in every ocean including Australia. I have books containing some 900 coast stations. Then there are two and three letter beacons for navigation, I have a list of 10000. You can learn Morse by listening to their slow Morse. For interest, if Mr Millmore draws a circle from

Wootton including the Faeroe (?) Isles, the Med and Black Sea, in that area alone he will hear the many ferries as they travel from port to port. The frequency 500kHz is universal and busy at all times.

I am now over 80 and this is my one hobby. Buy the right gear and the right books on frequencies and he will find many pages devoted to c.w. stations. For me c.w. is sweet music. I am not very interested in broadcast.

Another advantage of c.w. is there can be more than one station transmitting and you can still concentrate on one transmission. Try sorting out a number of speech transmissions under those conditions. I am not a Ham. The circle I mention above covers the area I listen to while I have breakfast each day. Wishing you good luck George, but please don't abandon Morse. It's so interesting.

**A. W. MANN  
MILFORD-ON-SEA**

**Dear Sir**

As a regular reader of SWM I feel I must congratulate you on the excellence of your magazine. The 'R210' articles were of special interest to me, and 'Trading Post', although overloaded with Japanese black boxes there are always a few traditional ex-government receivers on offer.

Reading through old copies of Short Wave, Wireless World, etc. memories come flooding back of Lisle Street WC2, Upper Saint Martins Lane, WC2, Wardour Street, WI to name a few, or the fabulous shops they contained from the late 40s to the mid 60s. A regular Eldorado for radio enthusiasts, for a few pounds you buy your first R1155, a R107 or the king of the receivers the AR88, the art of discovering work radio frequencies, both amateur and commercial, without the aid of a digital readout and memory recall. Ah, happy days.

That progress I suppose, so I'm told. Often the world of radio cannot look back, but I wonder if the younger hams know what a time they missed. No matter what you asked for it could be found in those Aladin's caves, nothing to much bother, no doubt you'll shake your collective heads and mutter under your breath 'senility', but the latest craze coming out of 'black box' country is a remote control device as used with television, all you have to do is relax in your armchair across the room and switch on, how lazy can we get? What's the purpose?

I know I will be attacked verbally by all the Kamikazi black box owners, but one man's meat, etc. I do have a few receivers myself and a very understanding wife, bless her, very necessary in my case, but happiness for me is using skill to find that elusive station you require, and when you have succeeded and the realisation that it was not a memory bank of oriental design, but your own brain that guided you. It's a lovely feeling. Still, it would be a funny old world if we all though alike, would it not.

Thanks again for the R210 article, please let's have more of the same.

**MR R. SHAW  
POOLE  
DORSET**

# A WORD IN EDGEWAYS

**Dear Sir**

Mr Millmore is to be congratulated (letters June 90), he has provoked me into putting pen to paper and I will no doubt not be alone amongst the amateur community!

Is Morse still needed and is it still in use? Hundreds of thousands of amateurs world-wide would say "Yes"

If Mr Wotton in fact can't hear them perhaps he should check his receiver or even switch on the b.f.o. and make sure the aerial hasn't dropped off!

The vocal minority have

been advocating the death of Morse for many years but the fact remains that it won't lie down. Over nearly forty years of operation I have not noticed any appreciable reductions in the use on the amateur bands. It will remain for as long as amateurs find it useful for simple and reliable communication.

Come on Mr Wotton, have a crack at it! Who knows, you may even discover another dimension to your hobby!

Don't you think there must be some reason why Morse is still with us after 150 years!  
**D. A. BUNDEY  
BATH, AVON**

**Dear Sir**

It is quite obvious that the reason Mr Millmore (June '90) failed to learn the Morse code was because of defective hearing. Anyone who can go through the amateur bands from 160m to 10m and not hear Morse code being transmitted on every available code section has a very serious hearing problem.

Some 75% of amateurs use Morse code and enjoy doing so, 5% of the transmissions from this station are done in Morse code.

It would appear that Mr Millmore not only advocates the abolition of Morse, but in his last sentence also has a half gripe at the RAE. Perhaps he would like to have this abolished also. To suggest that electronic gimmickry replace the Morse code is nothing short of sacrilege.

It takes a lot more discipline and dedication to learn Morse, than to learn to press the right button. Apes are capable of operating electronic appliances, such as computers, as was adequately demonstrated on a recent television programme from the States.

If Mr Millmore finds the Morse code and possibly the RAE so irksome I would suggest he takes up another hobby and leave amateur radio to the people who are prepared to put themselves under considerable discipline in order to obtain a licence.

Spare a thought for the Russians, Chinese, Japanese, etc, who not only have to learn the code but English as well!

**WILLIAM MITCHELL  
E15GQ  
CO WICKLOW  
REP OF IRELAND**

**Dear Sir**

I have just read George Millmore's letter in June 1990, where he states that if one scans between 150kHz-30MHz very few, if any, Morse transmissions are heard.

My RX picks up, without exaggeration, hundreds of Morse transmissions. The m.w. bands are a constant babble of Morse between coast stations and ferries/deepsea vessels moving in/out of European ports. The s.w. bands are packed with Morse transmissions between international stations and deepsea vessels sailing the seven seas.

I am now extremely worried! Am I hearing things?  
**BRIAN SINGLETON, FRECKLETON, LANCOS**

**Dear Sir**

Having been a short wave listener for the past three years and spent 90% of that time listening on the amateur bands, I have heard some interesting points of view.

However of late the most talked about subject must be the Novice Licence. I don't see why the A-licences are so against new blood coming into amateur radio. Is it because they feel their personal use of the amateur bands is now threatened and that in the future it will deteriorate into an expensive CB like system? I don't think any idiot CB user (of which I agree there are too many) would go to the trouble and expense of becoming an amateur. Secondly I think amateurs who feel any new licensee should be regarded as an inferior operator should think back to when they first operated on the amateur bands. I'm sure they must have made a few mistakes and waffled on a bit also.

Everyone has to learn, so come on chaps, how about a bit of an arrangement for the newly licensed and future licencees, of which I hope to be one! Radio is a fascinating hobby and it has to be available to all. Instead of complaining about the novice licence let's consider the genuine enthusiast of which I am one, who needs help and guidance from the licensed fraternity who are in a privileged position to be able to comment on those who are struggling to be a part of a rewarding hobby in which friends can be made in this country or any other without even leaving your seat!

Good luck to all who sat the RAE in May. Roll on August when we get our results, I'm getting very anxious, how about you?  
**MARTIN WILLIAMS  
MID GLAM  
SOUTH WALES**

**Dear Sir**

I must question the comments by George Millmore, June 1990, that "between 150kHz and 30MHz very few, if any, Morse transmissions will be heard". There are thousands of stations using the code. Apart from radio amateurs themselves who find that Morse reduces language barriers and gets through the QRM where voice wouldn't at much lower powers, there are maritime d.f. beacons using two or three letter call signs, shipping (I heard Danish news to ships in c.w.), mystery single letter beacons (U, K, W, etc) are all over the place, many so called 'number stations' are transmitting 'cut numbers' to the more proficient spies who don't need a voice reading them and even aircraft such as Aeroflot airliners. I basically agree with the letter's sentiments but Morse will stay for a few more years yet.

**SIMON MASON, HULL, HUMBERSIDE**

**Dear Sir**

Re Phil Townsend's letter in the June SWM.

Out of curiosity I had to look up the quotations in Mr Townsend's letter in the June SWM. I find the wording is the same as in my Vol II of Tucker & Wilkinsons, although my edition is 1954.

Mr Townsend is of course right to bring the subject forward. If you care to look at the specifications for a Matching Unit you will probably find that the insertion loss is about 0.5dB. That does not seem a great amount until you realise that 0.5dB is a little more than 10%. Add to that the loss in ordinary co-axial which can easily be another 10%, even at 14MHz, you will see 20% of your received signal has disappeared before it has reached the receiver. For the transmitting amateur the output power has been reduced by 20% in warming up his matching unit and co-axial cable before it reaches the aerial.

An answer that goes

some way toward overcoming the losses in a matching unit is to either leave the unit uncovered or to house it in a wooden or non-conducting material. Keep the antenna system above ground including the matching unit, couple only by inductive link with a faraday screen. Isolate the unit as far as possible from metal objects, pipes, etc, and of course the rig. See ARRL Antenna Handbooks 13th edition and earlier, the 14th edition does not cover this subject so well. Also HF Antennas For All Locations, Moxon G6XN.

The popular 'Transmatch' is quite a lossy device by the way, see pages 4-7 in the ARRL Antenna Handbook 14th edition, "insertion loss was measured at less than 0.5dB at 600 watts of power on 7MHz!" Less than 0.5dB could mean 0.49dB loss, but whatever the figure a loss approaching 60 watts is really unacceptable.

**PETER BUCHAN  
CAMBRIDGE**



# WHAT'S NEW

## Unusual Uses

Radio equipment gets used in the oddest of places. Bulgin's tough, water-proof, Buccaneer cable connectors are playing a vital part in the Shearwater Project, Dyfed Wildlife Trust's attempt to re-introduce a colony of Manx Shearwaters to Cardigan Island. The products are being used to connect up a solar-powered sound system, broadcasting the birds' calls, which experts hope will attract the species back to the island.

The committee have initiated a new phase of the project, the experimental use of sound recordings to create an audible impression of an established colony. Following an initial £600 donation from Crest Holdings - whose logo is a stylised shearwater - a wide range of industries not normally involved in conservation became interested in the project, supplying equipment and carrying out research and development on the Trust's behalf.

The resulting sound broadcasting equipment package comprised a sophisticated stand-alone solar-powered static-RAM recorder capable of broadcasting up to 55W of bird call, switching itself on and off automatically. It was designed to operate unattended even in severe maritime weather for up to five years with minimal maintenance. Its ETI amplifier is installed in a die-cast aluminium case and the Trust, recognising that the connections from the case to the rest of the equipment would have to be waterproof and rugged enough to withstand the hostile marine environment for up to five years, asked the advice of A F Bulgin & Co plc.

Bulgin's Buccaneer cable connectors are manufactured in the UK to specification IP68 of BS5490, making them suitable for extended continuous use in wet or hostile environments. The flex-mounted half of each unit locks to its partner with a specially designed threaded 'collar' which prevents accidental disconnection, while their virtually indestructible, black glass-filled nylon bodies combined with their wide operating temperature range (-20°C to +70°C) ensure total reliability even under the most rigorous conditions.

The equipment was air-lifted out to Cardigan Island by a Sea King helicopter and was activated at the end of February - the start of the Shearwaters' 1990 breeding season.



## Radio Newsreel

The BBC radio programme that pioneered on-the-spot news reporting is celebrating its fiftieth anniversary on the air in July.

*Radio Newsreel*, first broadcast from war-torn London in July 1940, continues today as one of the flagship news programmes on the BBC World Service. Up to three editions daily bring listeners world-wide news of events as they happen with despatches from BBC correspondents all over the world. The programme is also re-broadcast by a growing number of radio stations - currently 64 in 25 countries.

In 1988 the programme was renamed simply *Newsreel* and the original signature tune *Imperial Echoes*, performed by the Central Band of the RAF was superseded by a new rendering from the BBC Radiophonic Workshop.

## Changes to the World Service

The BBC World Service is to make changes to some of the language services in which it broadcasts and the hours devoted to those broadcasts. The package of changes, the first part of a major review of World Service for its next three-year funding period, was agreed after details discussions with the Foreign and Commonwealth Office.

### The changes in detail

Russian up by 3 hours 30 mins a week to 49 hours 30 mins

Mandarin Chinese up by 3 hours 30 mins a week to 24 hours 30 mins

Vietnamese up by 1 hour 45 mins a week to 10 hours 30 mins

English to Western Europe up by 3 hours 30 mins a week

English to the subcontinent up by 1

hour a week (a special 15 minute programme every weekday instead of just once a week)

English to East Asia up by 1 hour a week (a special 15 minute programme every weekday instead of just once a week)

English to South and East Asia - a new service to encourage the learning of English of 5 hours a week

Malay, currently 1 hour 45 mins a week, to cease

Japanese, currently 7 hours a week, to cease

Latin America - direct broadcasts are being decreased by 10 hours 30 mins a week in Spanish and 1 hour 45 mins in Brazilian but more resources are being put into rebroadcasts for local stations.

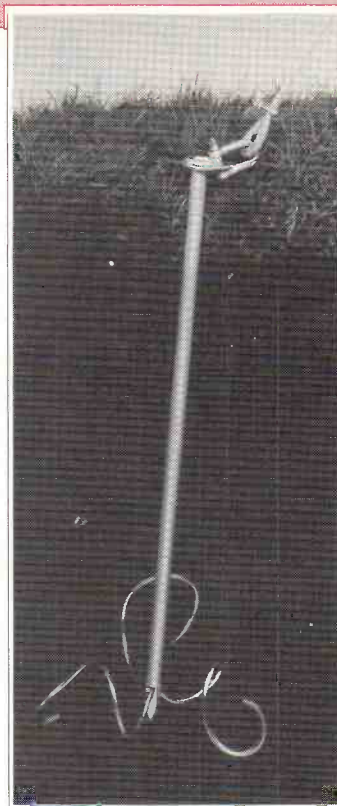

## Gale Warnings

We have all seen the images of havoc caused by the storms at the beginning of the year. Are you ready for the next gale, whenever that may be?

The Holtwood Ground Anchor is a device which can provide a strong anchorage point in almost any location in a matter of a couple of minutes. The anchor comprises a hardened steel tube which is knocked into the ground with a hammer. Inside this tube are three steel rods which are then driven out into the ground, curling like a pig's tail as they take a firm grip of the subsoil. All that is left showing above the ground is the anchorage ring which is an integral part of the anchor.

**Holtwood Engineering Ltd, 11 Brassey Drive, Holtwood, Aylesford, Kent ME20 7QL. Tel: (0622) 710921.**



# WHAT'S NEW

## Portable 'Scope

A full-function, dual-trace, 15MHz, battery/mains, miniature, portable oscilloscope has been designed and manufactured by Black Star Ltd.

The 1502 has two Y (vertical) channels, provided to enable timing and amplitude comparisons, and signal add/subtract. It has a 40 x 30mm display area with 5 x 4 divisions. The 1502 operates independently of mains power from its own optional rechargeable battery pack (six C-size cells) or from 48-62Hz a.c. mains supplies of 220 or 240V ( $\pm 10\%$ ). The mains supply recharges the battery pack while the 1502 is in use.

Vertical sensitivity is switchable in 1-2-5 steps from 10mV/div to 50V/div and the input accepts standard 1M $\Omega$  compatible probes. There is a switched choice of d.c. or a.c. coupling and a bandwidth of 15MHz over the full input range. As well as signal add/subtract already noted, chopped or alternate vertical display modes are available. The horizontal timebase is switch selected in 1-2-5 steps from 100ns/div to 0.5s/div, a total of 21 sweep speeds and an X-Y display facility is also provided.

The 1502 offers a full complement of triggering functions, with Auto or Normal modes; Channel 1, Channel 2 or External sources, a.c., d.c., TV line or TV frame sync source and +ve or -ve slope. These features make it ideal for engineers who regularly carry out on-site servicing of displays, TV equipment and v.d.u.s but who cannot afford the encumbrance of a conventional 'scope, or who cannot guarantee access to a mains supply.

Housed in a tough, moulded ABS case with tilt stand, the 1502 measures just 219 x 240 x 98mm and weighs 2.6kg, making it ideal for go-anywhere use. An optional protective carrying case with strap is available.

The instrument is supplied with 2 probes, a mains lead and full instruction manual, and is available now at the UK

## Stereo TV in Central Scotland

NICAM Digital Stereo comes to ITV and Channel 4 in Central Scotland from June 29 as part of an IBA initiative to bring the new digital audio technology to almost 80% of British viewers by the end of the year.

NICAM stands for Near-Instantaneously Companded Audio Multiplex. It adds a special digital signal to a standard television transmission to enable reception of stereo sound with quality similar to Compact Disc. The system can also be used to provide a second language soundtrack.

In order to receive NICAM, it is necessary to have a TV set or video cassette recorder incorporating a NICAM decoder. In the last year or two, a wide variety of receivers and v.c.r.s have been produced with the option of NICAM sound. Older sets with stereo speakers will probably not be stereo equipped.

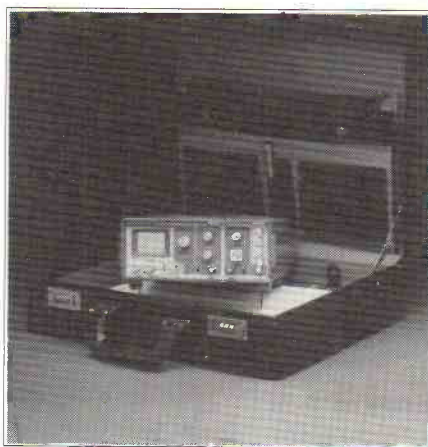

price of £375 plus VAT.

**Black Star Ltd, 4 Harding Way, Somersham Road, St Ives, Huntingdon, Cambs PE17 4WR. Tel: (0480) 62440**

## On The Move

**Garex Electronics**, with its long established reputation for the supply of reconditioned commercial radio-telephone equipment and spares, mobile antennas, scanning receivers and weather satellite systems is moving to new and larger premises at **Station Yard, South Brent, Devon** on August 6.

Very conveniently located just off the main A38 road between Exeter and Plymouth, visitors will be made particularly welcome at their retail counter between 10am and 5pm Monday to Friday.

## UK Spec CB

The TSM404UK will be of particular interest to car owners since it has the speaker mounted on the front of the radio. The radio incorporates a sophisticated volume squelch system that eliminates unwanted interference from car or truck ignition systems - only allowing the squelch circuit to work when an f.m. transmission is present.

With selectable roger bleep and tone controls built-in the radio will retail for £79.95.

**Nevada, 189 London Road, North End, Portsmouth, Hampshire PO2 9AE. Tel: (0705) 662145**

## Tandy Modifications

Owners of the Tandy PRO-2004 and PRO-2005 scanners may be interested to know of a modification available that adds a search and remember facility. There are two modifications modules available. The PS-90 has two modes of operation, a simple mode where frequencies found during a search are stored in the ten monitor memories and a complex mode where the frequencies are stored directly in the scanners main memory.

The SS-45 module has only one mode of operation and this stores the frequencies found during a search in the monitor memories.

For full details on these modules and information on fitting them, contact:

**B S Sutherland, 336 Charlton Road, Bristol BS10 6JZ. Tel: (0272) 500742**

## RAE Courses

**Belfast:** The College of Technology, Belfast. RAE classes on Tuesdays, 1730 to 2000. Enrolment week starts Monday September 3. Contact, Mr J E Wilson G13NEB. Tel: 327244 ext 297.

**Manchester:** North Trafford College, Talbot Road, Stretford. RAE classes on Monday evenings or Wednesday mornings, Morse Code on Tuesday evenings or Wednesday afternoons, Amateur TV on Wednesday mornings and Advanced Morse Code classes on Monday evenings. Lecturer is J T Beaumont G3NGD. Enrolment dates are September 5, 6 and 7.

**Clacton-on-Sea:** Green Lodge Education Centre, Old Road, Clacton-on-Sea. RAE classes start September 1990. Enrolment is during the week commencing September 10. Reg Taylor G0NIP. Tel: (0255) 430466.

**London:** City of Westminster College (formerly Paddington College), 25 Paddington Green, London W2. RAE and Morse classes start September 1990. Ann James. Tel: 071-723 8826.

**Leeds:** Joseph Priestley Institute, Morley, Nr Leeds. RAE classes on Wednesday evenings from 7 - 9pm. Morse classes on Tuesday evenings from 7 - 9pm. Electronics classes on Thursday evenings from 7 - 9pm. Enrolment starts September 3. Contact the college on Leeds 532782.

**Harrow:** Weald College, Brookshill, Harrow, Middlesex. RAE classes start Wednesday September 26 at 6.45pm. Enrolment details on 081-954 9571.

**Nottingham:** Arnold & Carlton College of Further Education, Digby Avenue, Mapperley, Nottingham. Full RAE course starts Wednesday September 12 at 6.30pm. Short RAE course starts Thursday September 13 at 6.30pm. Morse classes start Wednesday September 12 at 7pm. Construction classes start Tuesday September 11 at 7pm. Ron Wilson. Tel: (0602) 876503.

**Cardiff:** British Telecom HQ, 25 Pendwyallt Road, Coryton, Cardiff. RAE classes start Tuesday September 25 from 7 - 9pm. C.G. Barry GW3BUT. Tel: (0222) 628430 daytime

**Brentford:** Brentford Community Education Centre, Brentford School, Clifden Road, Brentford. RAE classes on Wednesdays from 7 - 9pm. Morse classes start on Thursday September 27 from 7 - 9pm. G1ZRY. Tel: 081-876 3183.

**Stockport:** Avondale Adult Education Centre, Heathbank Road, Cheadle Heath, Stockport. Morse classes on Monday evenings from 7 - 9pm, RAE classes Tuesday evenings from 7 - 9pm. Rik Whittaker G4WAU. Tel: 061-427 4730 evenings and weekends.

**Romford:** Havering College of Further and Higher Education, Quarles Campus, Tring Gardens, Harold Hill, Romford. RAE classes on Tuesdays evenings, Morse classes on Thursday evenings. Contact Stuart Woosnam G0NKP or Chris Potarzycki G0NJR via the college.

**Bristol:** Brunel College of Technology, Ashley Down, Bristol. RAE classes on Monday evenings from September 10, Morse classes on Tuesday evenings from September 11, Practical classes on Thursday evenings. Enrolment on September 4 or 5. David Heald. Tel: (0272) 241241 ext 2190.

**Hounslow:** Science and Technology Department, The Henley College, Deanfield Avenue, Henley-on-Thames. RAE classes on Wednesday evenings from 7 - 9.30pm. Bob Humphreys. Tel: (0491) 579988 ext 298.

**Cambridge:** Chesterton Community College, Gilbert Road, Cambridge. RAE classes on Monday evenings 7 - 9pm. Lessons start on Monday September 24. Enrolment is on September 10 or 11, 7 - 9pm. Lecturer is Martin Mann G4FFO. Tel: (0223) 860150.



# GRASSROOTS

Lorna Mower

**Bromley & District ARS** meet 3rd Tuesdays, 7.30pm at The Victory Social Club, Kechill Gardens, Hayes, Kent. August 12 is an operating evening. Geoffrey Milne G3UMI on 081-462 2689.

**Bedford & District ARC** meet Tuesdays at Allens Club, Hurst Grove, Bedford. August 7/14 are social evenings and the 21st is Preparations for Special event stations GBOJDC/GB0BOB. Glenn G0GBI on Bedford 266443.

**Reading & District ARC** have a Boat Trip to Burghfield on August 2, an illustrated talk on the club's history by G4JTR on the 9th and a Special Event Station at the Knowl Hill Steam Rally in aid of Hospital Radio Reading on the 11th. Meetings at The Woodley Pavilion, Woodford Park, Haddon Drive, Woodley, 8pm. Mike Anthony G4THN on Bradfield 744042.

**Binstead ARS** meet Mondays, 7.30pm at Brickfields Shire Horse Centre, Newnham Rd, Binstead, Nr Ryde, Isle Of Wight. Derek Barnes G4VJF on Isle of Wight 611912.

**Salop ARS** meet Thursdays, 8pm at "Ye Olde Bucks Head", Frankwell, Shrewsbury. August 2 is a Visit to the BBC transmitter at Woofferton and the 16th is a talk by the Chief Engineer at Beacon Radio on his work. Fred Hall G3NSY on Shrewsbury 790457.

**Gravesend ARS** meet Mondays, 8pm at the Coach & Horses Public House, Parrock Street. Phil Jobson G3HLF on Gravesend 534571.

**Bromsgrove & District ARC** meet 2nd Fridays, 8pm at Avoncroft Arts Centre. Details from Trevor Harper G0KIN, 5 Chesworth Rd, Harwood Park, Bromsgrove, Worcestershire B60 2HF. Tel: Bromsgrove 33173.

**Horndean & District ARC** meet 1st Thursdays, 7.30pm at Horndean Community School, Barton Cross, off Catherington Lane. August 2 is Maritime Ramblings by Doug G4BEO. F. Charrett G3COO on Havant 483676.

**Mid-Warwickshire ARS** meet 2nd & 4th Tuesdays, 8pm at 61 Emscote Rd (St Johns Ambulance HQ). August 14 is a families' evening get-together. Mike Newell G1HGD on Kenilworth 513073.

**Chesham & District ARS** meet Wednesdays, 8pm at The Stable Loft, Bury Farm, Pednor Rd. Liz Cabban G0ETU on Chorley Wood 83911.

**Norfolk ARC** have Meteor Scatter by G4IJE on August 1, a Club Outing to Worburn Rally on the 5th, a Real Radio evening on the 15th and Amateur Radio Programmes for the Micro on the 22nd. Wednesdays, 7.30pm in The Norfolk Dumpling, The Livestock Market, Harford, Norwich. Steve Sewell G4VCE on Mulbarton 78258.

**Rugby ATS** meet Tuesdays, 7.30pm at the Cricket Pavilion, outside Rugby Radio Station. July 29 is their 2nd Annual Car Boot Sale, August 7 is a St Kilda Island talk and the 14th is a 144MHz direction finding competition round four. Kevin Marriott G8TWH on Coventry 441590.

**Southgate ARC** have a talk on Nicam Stereo by Gerry Meek of Fergusons on August 9 and a DF equipment checking evening on the 23rd. Meetings at the Holy Trinity Church Hall (Upper), Winchmore Hill, London N21, 7.45pm. Brian Shelton on 081-360 2453.

**Stevenage & District ARS** have a committee meeting at 81 Whomerley Rd on July 26. 1st & 3rd Tuesdays, 8pm in Ground Floor Lecture Room, "D" Block, Ridgemoor Training Enterprise, Ridgemoor Park. Peter Daly G0GTE on Stevenage 724991.

**West Manchester RC** meet Wednesdays at Astley & Tyldesley Miners Welfare Club, Meanley Rd, Gin Pit Village, Astley, Frank Hilton G4NRN, 46 Hamilton Street, Atherton, Manchester M29 0AT. Tel: 0942 884614.

**Trowbridge & District ARC** meet 1st & 3rd Wednesdays, 8pm at the Territorial Army Centre, Bythesea Rd. August 1 is a Visit from G1YOA to talk on Auroral Prediction and Magnetometers and the 15th is a natter night. Ian G0GRI on Bratton 830383.

**Keighley ARS** meet twice monthly, 8pm in the Clubroom, rear of Victoria Hall. July 31 is Visit YPL Television, August 7/21 are natter nights and the 14th is night on the air G0KRS. Kathy on Bradford 496222.

**South Bristol ARC** have a Film & Slide Bring & Buy evening by Ron Gardner on August 1, a 2m Activity evening on the 8th, DX Broadcast TV Activity on the 15th and Top Band Activity evening on the 22nd. Wednesdays at Whithchurch Folkhouse, East Dundry Rd, Whithchurch. Len Baker G4RZY on Whithchurch 832222.

**Delyn RC** meet every other Tuesday, 8pm in the Daniel Owen Centre, Mold. July 31 is the work of Jodrell Bank by a well-known scientist and August 14 is an Open Forum and discussion night. Steve Studdart on Deeside 819618.

**Aylesbury Vale RS** meet 1st & 3rd Wednesdays, 8pm at Hardwick Village Hall, Aylesbury, Bucks. Martyn Baker G0GMB on Milton Keynes 560026.

**Farnborough & District RS** meet 2nd & 4th Wednesdays, 7.30pm at the Railway Enthusiasts Club, 103 Hawley Lane (by M3 bridge). Tim FitzGerald G4UQE on Camberley 29231.

**Derby & District ARS** have a Junk Sale on August 1, Rally Preparation on the 8th and Solid State Amplifiers by G2SP on the 15th. Wednesdays, 7.30pm at 119 Green Lane, Derby. Kevin Jones G4FPY on Derby 669157.

**Felixstowe & District ARS** have a talk on the Novice Licence by a speaker from the RSGB on August 6 and a DF Hunt and Barbecue on the 19th. Alternate Mondays, 8pm in the Back Room of the Ferry Boat Inn, Felixstowe Ferry. Paul Whiting G4YQC on Ipswich 642595 daytime.

**Wimbledon & District ARS** meet 2nd & last Fridays, 7.30pm in St Andrews Church Hall, Herbert Rd. July 27 is a pre-camp meeting, August 10 is a night on the air (at camp), 4/12 is WDARS Summer camp and the 13th is a CATS v WDARS Quiz at CATS. Nick Lawlor G6AJY on 081-330 2703.

**Yeovil ARS** have a natter night on July 26, Designing iFet Amplifiers G3MYM on August 2, Designing iFet Oscillators G3MYM on the 9th, Tuned Circuits G3MYM on the 16th and SSB G3MYM on the 23rd. Thursdays, 7.30pm at The Recreation Centre, Chilton Grove. David Bailey G1MNM QTHR or their Chairman Adrian G4JBH on Yeovil 28341.

**Carlisle & District ARS** meets Mondays, 7.30pm in the Morton Community Centre, Wigton Rd. Roy Brammell G0HNQ on Wigton 44766.

**Cheshunt & District ARC** meet Wednesdays, 8pm in the Church Room, Church Lane, Wormley. August 1/15 are natter nights and the 22nd is a Portable evening. Roger Frisby G4OAA on Hoddesdon 464795.

**Sutton & Cheam RS** have a 144MHz low power contest on July 28, a 432MHz low power contest on the 29th, committee meeting on August 1 and a natter night on the 6th. Meet

3rd Thursdays, 7.30pm at Downs Lawn Tennis Club, Holland Ave, Cheam with natter nights on 1st Mondays in the Downs Bar. John Puttock G0BVV at 63 Alexandra Ave, Sutton, Surrey SM1 2PA.

**Vale of Evesham ARC** meet 1st Thursdays, 8pm at the MEB Club, Old Worcester Rd, Evesham. August 2 is Technical Ceramics by G8BKL. Ken Sheldon G4NIJ on Evesham 860202.

**Plymouth RC** meet Tuesdays, 7.30pm at Frederick Street Community Centre (just off King Street). Bob Slater on 0752 361842.

**Acton, Brentford & Chiswick ARC** have a discussion on Variable low-power stabilised power supplies on August 21. Tuesdays, 7.30pm at the Chiswick Town Hall, High Rd, Chiswick, London W4. Details from P. Truitt at above address.

**Morecombe Bay ARS** meet Tuesdays, 7.30pm at Trimpell Sports & Social Club, Outmoss Lane, Morecombe, Lancs. Details from Derek Wood G4ZJL, 29 Oakville Rd, Higher Heysham, Nr Morecombe, Lancashire LA3 2TB. Tel: Heysham 52042.

**Banbury ARS** meet 2nd & 4th Wednesdays in the Lounge Bar of the 'Three Pigeons' Public House, Castle Street. Bryan Thornton G1HIO, 21 Valley Road, Banbury, Oxon OX16 9BQ. Tel: Banbury 251774.

**Coventry ARS** meet Fridays, 8pm at Baden Powell House, 121 St Nicholas St, Radford. July 27/August 3 are nights on the air and Morse tuition, August 10 is a computer night and the 17th is an outdoor operation evening. Neil Blair G7ASZ on Coventry 523629.

**Chelmsford ARS** have DF events on July 29/August 3 and a club meeting on August 7. 1st Tuesdays, 7.30pm at Marconi College, Arbour Lane. Roy Martyr G3PMX on Chelmsford 353221 Ext 3815 office.

**Wirral ARS** have Workshop Practices by G3PYV on August 1 and a fox hunt on the 15th. 1st & 3rd Wednesdays, 8pm in the Club Room of Ivy Farm, Arrowe Park Rd, Birkenhead (opposite Landican cemetery gates). Alec Seed G3FOO at 31 Withert Ave, Bebington, Wirral L63 5NE.

**East Kent RS** meet 1st & 3rd Thursdays, 7.30pm in the Cabin Youth Centre, Kings Rd, Herne Bay. August 2 is an Operating night at Bishopstone and the 16th is a Barbecue. Brian Tutt G4ZZK on Herne Bay 366232.

**South Manchester RC** meet Fridays, 8pm at Sale Moor Community Centre, Norris Rd, Sale. Ian Butterworth on 061-231 5870.

**Club Secretaries:..**  
Send all details of your club's  
up-and-coming events to:  
**'Grassroots', Short Wave Magazine,**  
**Enefco House, The Quay,**  
**Poole, Dorset BH15 1PP**



# TRADING POST

**FOR SALE** Uniden Bearcat Scanner UBC 200XLT covers up to 956MHz, unwanted present, complete with mains adaptor still under warranty. Cost £230 will accept £155 o.n.o. K. Faulkner, Site 24, Cuttles Ridge, old Ballygowan Rd, Comber, Co Down BT23.

**FOR SALE** AOR-2001 25-550MHz, 20 memories, scan and search facilities, power pack, instructions and box, £210 o.n.o. Neil Carstairs, 17 Lea Close, Claines, Worcester WR3 7PR. Tel: Worcester 51849.

**FOR SALE** Drake R7 receiver and Drake MS4 speaker, £500. Owen Murphy. Tel: Epsom 726539.

**FOR SALE** AOR-2002 scanner as new complete with all accessories and original carton, £250. Brian Russell. Tel: Fordingbridge 56157.

**FOR SALE** Uniden Bearcat 200XLT, in very good condition, with second antenna and box, £165. W. Davis. Tel: Welwyn Garden 332636.

**FOR SALE** Matsui MR-4099 receiver, with manual, boxed, as new, £45 carr extra. Denco GP coils, 2-5 red, blue, yellow. Also 3-5 blue range. Seon Smyth, 'De Porres', 67 East Princes Street, Helensburgh G84 7DG. Tel: Helensburgh 71181.

**FOR SALE** Grundig Satellit 1400 professional, excellent condition, little used, £80. Reason for sale purchase of Trio 1000. J. Poulton. Tel: Newtown 626153.

**FOR SALE** Black Jaguar BJ200 MkII hand-held v.h.f./u.h.f. scanner, complete with battery charger, a.c. power supply and d.c. power supply, earphone, case, etc, all in good condition. Genuine reason for sale, £165 the lot. K. Jones, 3 Cobham Close, Canterbury, Kent CT1 1YL.

**EXCHANGE** Trio R2000 C with v.h.f. VC10 converter, cost £756, plus manuals. **For** AOR-2002 plus AR-1000 or similar. Reason for Exchange have purchased FRG-8800 (accessories please). E. Sands, 14 Timon Ave, Bootle, Merseyside L20 9DZ. Tel: 051-521 7794.

**FOR SALE** Bearcat 200XLT scanner, as new, 200 memories, includes charger, NiCads, case, headset, rubber duck and telescopic antennas, £165 o.n.o. **Wanted** ERA microreader MkII preferred or Spectrum computer. M. Hoey. Tel: Blackpool 32410.

**FOR SALE** Tono 550 communication terminal c.w., RTTY, ASCII, baudot receiving rate 45, 50, 56, 74, 100, two -page display, etc, mint condition, boxed, manual, etc, £300. J. Wingrove. Tel: 071-228 4835.

**FOR SALE** ERA microreader MkI, unwanted Christmas gift, used twice, original box and manual, £110 o.v.n.o. H. Davies. Tel: Aberdare 876586.

**FOR SALE** Realistic PRO-2005, seven months old, reason for sale, too big to go mobile, £270. M. Downes. Tel: 071-922 4819 (8am-4pm).

**FOR SALE** AR-800E scanner 75-105, 118-136, 140-174, 405-495, 830-950, charger, boxed, mint condition, £120. M. Hayes. Tel: Folkestone 872048.

**FOR SALE** Kenwood Trio R2000 without VC v.h.f. converter manual and leads, £425 or near offer, immaculate well cared for set. Mr Cope. Tel: Burton-on-Trent 790193 day or night.

**FOR SALE** Sony Air-7, mint condition, £135. AB1S wide-band amplifier, 25-2100MHz, mint, £45. Sony ICF-601L excellent 12 band short wave receiver, mint £45. T. Wood G4MIZ. Tel: Haywards Heath, West Sussex 241567.

**FOR SALE** Signal R-528 hand-held aircraft band receiver, good condition, civil airband crystals included, £50. Ray Hubbard on Byfleet, Surrey 340468.

**FOR SALE** AOR AR-950 compact, lightweight, mobile/base scanner, 100 memories, covers complete civil and military airband, cellular, etc, still under guarantee, boxed, as new, £175. J. Ryder. Tel: Bristol 861589.

**FOR SALE** Kenwood R-1000 with FRT-7700 antenna tuner, excellent condition and full working order, manual, instructions, etc, £200. Reg Hunt. Tel: Steyning, West Sussex 816289.

**FOR SALE** Sony 2001D, 20 months old, hardly used, as new, will accept £170. Can deliver over reasonable distance, phone any evening after 7.30pm. Mr N. Wirsten. Tel: Selkirk 22857.

**FOR SALE** AOR AR-900 v.h.f./u.h.f. hand-held scanner, 108-136, 137-174, 220-290, 291-380, 406-470, 830-950MHz, £150. J. Cottingham, 'Brenton', School Lane, Snittery, Gainsborough, Lincolnshire DN21 4TS.

**FOR SALE** Lowe HF-225 receiver, gene pad, whip aerial & deluxe case, £375. Sony AN1 aerial, £38. All only three weeks old, genuine reason for sale. E. Hargreaves. Tel: Horsforth, Leeds 589346 after 6pm.

**WANTED** Hamgear PMX preselector, mains powered, must be in good working condition and unmodified, reasonable price paid. Mr E. Chorley. Tel: 081-204 7734 after 6pm

**FOR SALE** Tandy Realistic PRO-32A, hand-held scanner with handbook and frequency lists, £99. A. Cockburn. Tel: 031-669 8972.

**FOR SALE** or SWAP Kenwood R820 h.f. receiver, boxed with manual. Yaesu FRG-9600 v.h.f./u.h.f. receiver scanner comes with discone aerial RDK converter to h.f. book, manual, w.h.y. in top quality digital h.f. receivers? L. Rogers. Tel: Reading 812476.

**FOR SALE** Matsui MR-4099 receiver, as new and boxed, £65. Log periodic beam 100-1300MHz, 12dB gain, £35. C Edwards. Tel: Swansea 467384.

**FOR SALE** Tandy PRO-2004 scanner, manual, books, £200. Datong D70 Morse tutor and hi-mound key, £50. Cambridge Z88 computer, extra 32k ram, £150. All as new. W. Willes. Tel: Dorchester 251721.

**WANTED** Pan-crusader, Elizabethan or similar 12-band radio receiver, good condition and working, cash or exchange. I will cover Securicor or postal charges. Mr J. Flaherty, 25 William Street, Twyn Merthyr, South Wales. Tel: Merthyr Tydfil 75025.

**HELP NEEDED** with a survey of airband radio users for a new book by Graham Duke (author of ARB Air Traffic Control). Send for survey form to G. R. Duke, 4 Ridgeway Grove, Newport, Gwent NP9 5AN.

**FOR SALE** Panasonic RF-B65 receiver with s.s.b., 153kHz-30MHz, 36 memories, m.p.u., £110. Fairmate HP-100E scanner, 25-550, 830-1300MHz, three antennas, NiCads, charger, 1000 memories, £175. Mint condition, boxed, manuals, still under guarantee. Keith Ferry on 081-570 5603.

**FOR SALE** Racal RA17, £135. Hamgear preselector, £45. Grove Tun-4 preselector, new, £70. Codar CR66 550kHz-30MHz, £14. US Aircraft c.w. TX, 5.3-7MHz, 28V, £15. Norman Melrose on 081-319 3157.

**FOR SALE** AOR AR-2002, 25-1300MHz scanner, £320. AOR-2001, 25-550MHz scanner, £120. Bearcat 10kHz-30MHz all-mode s.w. receiver, £170. 40-channel, hand-held 4W-CB transceiver (Realistic), £60. C. Wood. Tel: 0889 563495 (Staffs).

**FOR SALE** Racal RA-17 h.f. receiver, £140. Eddystone 730/4 h.f. receiver, £70. Pye Europa u.h.f. on RB6, RB11, SU8, RX needs retuning, £30. Eric Carvill. Tel: Eastbourne 768656.

**FOR SALE** SEMQRM eliminator MkII, 100kHz-60MHz, £60. Yaesu FRT-7700 a.t.u., £45. Both new and unused. Offers. Mr T. Best. Tel: Gosport 521756.

**FOR SALE** Eddystone 830, general coverage receiver, 300kHz-30MHz, speaker, spare valves, handbook, £120. Eddystone 888 with manual, £60. Army 128 TX/RX QRP c.w., circuit, £40. Eddystone EC10II, £20. J. Stirrat. Tel: Sittingbourne, Kent 473996.

**FOR SALE** Signal R532 v.h.f. airband receiver in good working order, £125. Keith. Tel: Bristol 248679 daytime or 685767 evenings.

**FOR SALE** Yaesu FRT-7700, a.t.u. and FF5, i.f. filter, £45 for the two. Boxed, as new. **Wanted** small 2m hand-held. D. Garner, 26 Wordsworth Ave, Warrington, Cheshire. Tel: Warrington 55924.

**FOR SALE** Lowe HF-225 with keypad and a.m. detector, boxed with manual, six months old, £425. N. Hartford. Tel: Telford 583388.

**SWAP** Realistic PRO-2009 v.h.f./u.h.f. 68-88, 144-174, 410-512 base scanner and manual for h.f. receiver or sell for £90 o.n.o. D. Simpson, 42 Wareham Way, Sunnybrow, Crook, Co Durham DL15 0NG.

**SWM AUGUST 90 TP**

Write out your advertisement in BLOCK CAPITALS - up to a maximum of 30 words plus 12 words for your address - and send it together with your payment of £2.30, to Trading Post, Short Wave magazine, Enerco House, The Quay, Poole, Dorset BH1 1PP. You must send the flash from this page, or your subscription number as proof of purchase of the magazine. Advertisements from traders, apparent traders or for equipment which it is illegal to possess, use or which cannot be licensed in the UK will not be accepted.



# When you are ready to graduate to real listening Look to Lowe

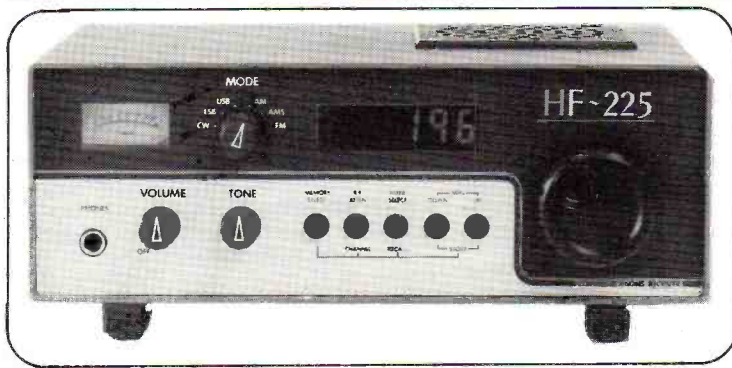

- |               |  | Price          | Carr          |
|---------------|--|----------------|---------------|
| <b>HF-225</b> | HF general coverage receiver, 30kHz to 30MHz.....  | <b>£425.00</b> | <b>£10.00</b> |
|               | (The HF-225 has been voted "Receiver of the Year" by World Radio and TV Handbook, against all other manufacturers' products) |                |               |
|               | Options  |                |               |
| <b>D-225</b>  | Synchronous AM and FM detector.....  | <b>£39.50</b>  | <b>£1.00</b>  |
| <b>K-225</b>  | Keypad for direct frequency entry.....   | <b>£39.50</b>  | <b>£1.00</b>  |
| <b>B-225</b>  | Internal NiCd battery pack.....  | <b>£49.00</b>  | <b>£2.50</b>  |
| <b>W-225</b>  | Active whip aerial.....  | <b>£19.50</b>  | <b>£2.50</b>  |
| <b>C-225</b>  | Delux carrying case for HF-225..   | <b>£23.86</b>  | <b>£3.00</b>  |
| <b>S-225</b>  | Wharfedale speaker and lead.....   | <b>£49.50</b>  | <b>£3.00</b>  |



- |                |  |                |               |
|----------------|--|----------------|---------------|
| <b>R-5000</b>  | Kenwood HF communications receiver. 100kHz to 30MHz..... | <b>£875.00</b> | <b>£10.00</b> |
|                | Options  |                |               |
| <b>DCK-2</b>   | 12volt dc power kit.....                                 | <b>£9.29</b>   | <b>£1.00</b>  |
| <b>VC-20</b>   | VHF converter for 108 to 174MHz.....                     | <b>£167.21</b> | <b>£3.00</b>  |
| <b>VS-1</b>    | Speech synthesiser for R-5000..                          | <b>£32.26</b>  | <b>£1.00</b>  |
| <b>YK88A-1</b> | 6kHz AM crystal filter.....                              | <b>£48.05</b>  | <b>£1.00</b>  |
| <b>YK88C</b>   | 500Hz CW filter.....                                     | <b>£46.08</b>  | <b>£1.00</b>  |
| <b>YK88CN</b>  | 270Hz CW filter.....                                     | <b>£54.64</b>  | <b>£1.00</b>  |
| <b>YK88SN</b>  | 1.8kHz SSB filter.....                                   | <b>£46.74</b>  | <b>£1.00</b>  |
| <b>SP-430</b>  | External speaker unit.....                               | <b>£40.81</b>  | <b>£2.50</b>  |



- |                |  |                 |               |
|----------------|--|-----------------|---------------|
| <b>NRD-525</b> | JRC communications receiver. 90kHz to 34MHz.....   | <b>£1095.00</b> | <b>£10.00</b> |
|                | Options  |                 |               |
| <b>CMK165</b>  | VHF/UHF converter. 34-60, 114-174, 423-456MHz..... | <b>£391.35</b>  | <b>£10.00</b> |
| <b>CMH530</b>  | RTTY demodulator.....                              | <b>£102.19</b>  | <b>£1.50</b>  |
| <b>CMH532</b>  | RS232 interface unit.....                          | <b>£91.75</b>   | <b>£1.50</b>  |
| <b>CFL231</b>  | 300Hz CW filter.....                               | <b>£126.37</b>  | <b>£1.00</b>  |
| <b>CFL232</b>  | 500Hz CW filter.....                               | <b>£126.37</b>  | <b>£1.00</b>  |
| <b>CFL233</b>  | 1kHz RTTY filter.....                              | <b>£126.37</b>  | <b>£1.00</b>  |
| <b>CFL218A</b> | 1.8kHz SSB filter.....                             | <b>£117.89</b>  | <b>£1.00</b>  |
| <b>NVA88</b>   | Matching external loudspeaker...                   | <b>£62.86</b>   | <b>£2.50</b>  |

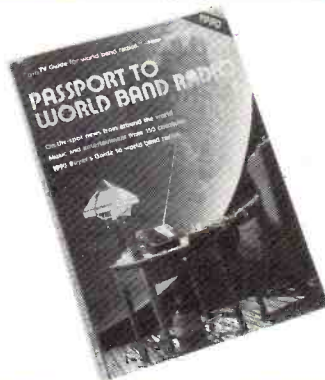

## THE LISTENERS' BOOK OF THE YEAR ..... £12.95

Never has a title been so well chosen as the "Passport to World Band Radio". This is the one book which seems to contain everything you need to know about listening to the amazingly diverse world of radio broadcasting. Let's just run through what this book contains:—

Obviously it has a complete listing of all short wave broadcasters, not simply in order of frequency, but also listing by language and country of origin, AND also the timing of the broadcasts. Almost two hundred pages of such information would make the book worthwhile on its own, but you also have detailed reviews and comment from an acknowledged and respected authority on such matters covering no less than forty radio receivers ranging from the sublime to the gor-blimey. To add to all this, you also get over a hundred pages of general news, views, and information.

The "Passport" is an absolutely indispensable companion to the short wave listener and the price is so reasonable for so much information. Get one soon before they are out of print.

The price for this constant companion. Slightly less than that for a pedigree dog. It's £12.95 for callers, or we can send it to you for an extra £1.55 for postage and packing.

# FREE

Send four first class stamps to cover the postage and we will send you, by return of post, you FREE copy of "THE LISTENERS GUIDE" (2nd edition), a commonsense look at radio listening on the LF, MF and HF bands. Its unique style will, I am sure, result in a "good read" but underneath the humour lies a wealth of experience and expertise. You will also receive detailed leaflets on our range of receivers and a copy of our current price list.

## LOWE ELECTRONICS LIMITED

Chesterfield Road, Matlock, Derbyshire DE4 5LE Telephone 0629 580800 (4 lines) Fax 580020 Telex 377482



# 26 YEARS IN SHORTWAVE

## When it comes to scanners Look to Lowe

### AR-3000 – The Ultimate Receiver



It is an acknowledged fact that AOR are the foremost manufacturer of VHF/UHF monitoring receivers in the world. In the AR-3000, even AOR have excelled themselves, because they have produced what is without doubt the ultimate receiver for wide band monitoring use.

Designed for the professional market, the AR-3000 is nevertheless affordable by the listening enthusiast, and the specification is enough to make any keen listener want this astounding receiver. Brief details:—

Imagine a frequency coverage from 100kHz to 2036Mhz: that's from below Radio 4 on the Long Wave to beyond satellites on 1.7GHz; and there are no gaps in the tuning range. Any frequency within this astounding range is yours to use as you wish.

Imagine all mode facilities, including AM, FM (communications), FM (broadcast), Upper Sideband, Lower Sideband, and even CW. Yours to command with the AR-3000.

Imagine tuning in 50Hz steps for accuracy on SSB/CW, with any step available at your choice from 50Hz to 100kHz, selectable in 50Hz increments. For really high speed tuning you can even increase all the steps by a factor of 10 by a touch of the main tuning knob.

Imagine 400 memory channels in 4 banks of 100, with each bank having its own priority channel, and each bank having its own programmable search system.

Imagine High speed scanning at 20 channels per second, with each memory channel having frequency, mode, and RF attenuator setting stored safely in it.

Imagine having a real time clock for accurate logging.

Imagine having a built in RS-232 computer interface for total control by a personal computer.

Imagine having all this with the outstanding performance which AOR built in to their famous AR-2002, but have now improved on for the AR-3000.

The AR-3000 is the monitor's dream receiver, and it is finally becoming available for general sale now that the Government orders have been fulfilled. Contact us right away for details of delivery schedules, and be prepared to own the best receiver anyone has yet produced.

AR-3000 — a dream come true.

**AR-3000.....£765 carr by Securicor £10**

For the past 26 years Lowe Electronics have specialised in seeking out the best in radio and bringing it to our customers. Those customers will also tell you that we have another speciality — looking after them. Whatever is best in radio, we sell. Whatever we sell, we back with really expert advice and service. We are pleased to represent the best companies in the receiver world, and in addition to the AOR range shown here, we also distribute receivers from Signal Communications and WIN, two of the top names in Airband radio. For full information and a copy of our Airband Guide, simply send us four first class stamps and mention that you saw our ad. in Short Wave Magazine". Happy listening.

Shops in **GLASGOW** Telephone 041-945 2626. **DARLINGTON** Telephone 0325 486121. **CAMBRIDGE** Telephone 0223 311230  
**BARRY** Telephone 0446 721304. **LONDON** Telephone 081-429 3256. **BOURNEMOUTH** Telephone 0202 577760  
 All branches are closed all day Monday.



# Short Wave Magazine

£1.60

AUGUST 1990

## REVIEWED

**Grundig Yacht Boy 220  
World Receiver**

## PLUS

**CIRKIT WEATHER  
SATELLITE RECEIVER**  
*Improvements to this  
popular system*

## AND

**Regular Features  
for Scanning,  
Airband  
and Broadcast  
Enthusiasts**



ISSN 0037-4261



9 770037 426005

*For The Radio Listener*



# NEVADA introduce the world's

# FIRST

## 1000 CHANNEL PROGRAMMABLE SCANNER

### the Fairmate HP100E

*packed full of the latest features*

- 8 - 600MHz and 830 - 1300MHz frequency coverage
- An incredible 1000 channel memory capacity
- 10 independent search bands
- A fast 40 channel per second search speed
- User-selectable search steps from 5kHz to 995kHz
- Modes - AM, FM and new Wideband FM for commercial reception
- Selectable 10dB attenuator
- Keypad and rotary tune controls

Each Fairmate 100E comes complete with:

- Full set of high capacity Ni-Cads
- Two antennas (one VHF, one UHF)
- Carry case
- Shoulder strap
- Belt clip
- DC cable
- Earpiece for private listening

**All this for  
£249**



**NEW LIMITED EDITION  
HP100E 'WBF' WIDE BAND VERSION  
COVERS 1-600MHz, 830-1300MHz,  
PRICE £289**

**Send £2  
for our latest Catalogue  
packed full of information  
on Scanners, Amateur & CB Radio**

**use your credit card for same day despatch  
HOTLINE: 0705 662145 FAX: 0705 690626**

**NEVADA  
COMMUNICATIONS**



# CIRKIT SATELLITE SYSTEM MODIFICATIONS

Peter Rouse (GU1DKD)

Last month we reviewed the Cirkit v.h.f. weather satellite receiver and although it passed the tests with flying colours, the original designers could not have foreseen the recent installation of high-powered paging transmitters less than 100kHz away from the satellite band edge.

This year for the first time, to my utter amazement, I started suffering problems with the National Paging services which operate on 138.075 and 138.175MHz. Despite living in the Channel Islands which are some 90 miles away from the English coast, on some days these transmissions completely obliterate the low level signals from the orbiting satellites. It is now estimated that hundreds of individuals, schools and colleges have had to modify or even close-down their stations because of these transmissions. The problem clearly lies with the ceramic filters and to my knowledge the vast majority of manufacturers producing receivers for this band use the same or similar 50kHz bandwidth roofing filters. However, whilst admitting the filters are to blame I must also query why these high powered transmitters with their 100W f.s.k. signals were given an allocation alongside an Earth-Space allocation in what appears to be disregard of ITU recommendations.

However, in some respects I am grateful for the interference because it led to an improvement in the performance of my own receiver during the process of trying to cure the problem.

## Cascading filters

Virtually any bi-directional filter of the type employed in these receivers can be cascaded, i.e. simply connect them nose-to-tail. However, you cannot just do this ad infinitum because of such problems

**Curing paging transmitter breakthrough, improving the signal-to-noise ratio, better stability for the demodulator oscillator and a simple squelch operated relay switch for turning-on a tape recorder.**

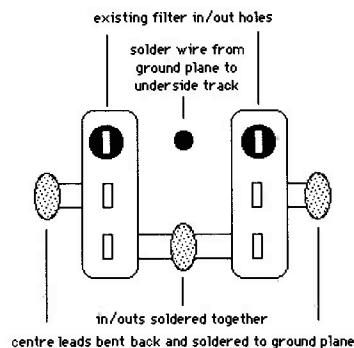

**Fig. 2: Top view of cascaded filter mounting arrangement and connections. It is important that a wire is soldered both sides of the old filter ground point to maintain earthing to other parts of the circuit.**

as group delay and insertion loss. The Cirkit receiver uses two filters. The one straight after the mixer is followed by a simple amplification stage which outputs to the second filter which in turn feeds into the i.f. i.c.

My initial move was to simply cascade a second filter onto each of the existing ones. I did not expect this to work, I simply wanted to see how much the insertion loss would affect the receiver's performance with a view to designing a further amplification/filter stage. To my utter surprise, it worked as it was. In fact

it did not just work but it considerably improved the overall signal-to-noise ratio.

Clearly what had happened was that the insertion loss had been traded-off against tighter bandwidth (the 50kHz is a shade too wide anyway but these are the closest off-the-shelf filters available). No attempt has been made to match the filters and the problem caused by the paging transmitters has gone.

I see no reason why a similar modification cannot be made to other receivers using the same filters and additional 50kHz roofing filters are available quite cheaply from both Cirkit Distribution and Maplin Electronic Supplies. As for the Cirkit receiver, I can thoroughly recommend the modification just for the improved noise factor alone. Simply unsolder the existing filters and solder a wire link into the existing hole for the centre ground pin. This maintains the earth to other parts of the circuitry. The paired filters are mounted side by side and in each case, the first filter has its input soldered to the original hole, the second has its output soldered to the original hole and centre ground pin of each is connected direct to the ground plane of the p.c.b. The remaining input/output connections from the filter are soldered together above the board.

You may need to re-trim T1 but that should be the only adjustment needed.

## Squelch Operated Relay

This simple circuit will allow the squelch to turn a relay on and off to control a tape recorder so that signals can be recorded whilst the station is unattended. Although it was designed for the Cirkit receiver it will also work with those scanners, such as the AOR, which employ the MC3357 f.m. i.f. chip.

On the circuit receiver, squelch output is available on pin 6 of the SL6601 chip and is brought out to a connection point on the p.c.b.. The turn-on, turn-off point is controlled by VR3 and when the squelch is closed, pin 6 goes high and then swings low when the squelch opens. This means that to operate a relay we only need a simple inverter/driver and this can be achieved using just two *npn* transistors. A BC109 and a BC107 are shown but in fact virtually any similar type will work. The capacitors simply slug the switching rate to stop the relay from chattering on marginal signals (for use with the MC3357 they can be omitted) and the values may need adjusting to suit the transistors used.

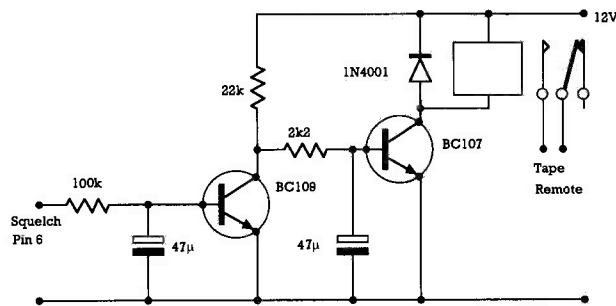

**Fig. 1: Tape recorder switching from the squelch pin. The circuit also works with any receiver using the MC3357 i.f. circuit.**



# CIRKIT SATELLITE SYSTEM MODIFICATIONS

Note that a ready made p.c.b. will not be available for this project. A couple of square inches of strip board is all that is needed to assemble the circuit anyway. If you are using it with the MC3357 then connect the input to pin-13.

## Demodulator Modification

The last modification concerns the master synchronisation oscillator in the demodulator reviewed in the May '89 issue.

The final 4.096kHz synchronisation signal is derived from an oscillator running at 4.194304MHz with subsequent division to the required frequency. In fact, the crystal's actual frequency is 4.194394MHz and in order to pull it down slightly a fairly high value resistor is used between the junction of the crystal and trimmer capacitor and pins 12 & 13 of IC1. It would appear that this resistor, R1 (22k $\Omega$ ) is to blame for slight drift due to temperature changes. Naturally, if the equipment is not subject to any major changes of room temperature and all is well then leave things as they are.

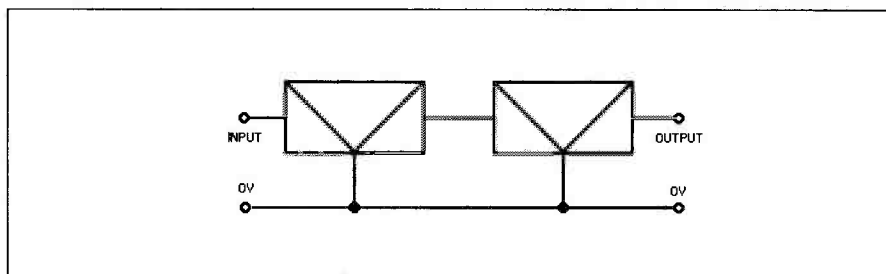

Fig. 3: 50kHz roofing filters cascaded in pairs to replace single filters.

However, if you do have the occasional leaning-picture syndrome then the cure is fairly simple. First replace the ceramic capacitor C2 with a high tolerance polystyrene 22pF type. Then reduce the value of R1 to 12k $\Omega$ . You may need to adjust the value up or down slightly for individual crystals but basically you should aim at getting the value as low as possible whilst still being able to trim the crystal to the exact required frequency. □

Abbreviations	
f.m.	frequency modulation
f.s.k.	frequency shift keying
i.c.	integrated circuit
i.f.	intermediate frequency
ITU	International Telegraphic Union
kHz	kilohertz
k $\Omega$	kilohms
MHz	megahertz
p.c.b.	printed circuit board
pF	picofarads
v.h.f.	very high frequency
W	watts

## LISTEN OUT FOR

**GB50BOB:** This station will be on the air from RAF Swinderby over the weekend of August 3/6 operated by the 204 ATC Squadron.

**GB50BOB:** The Science Museum Wroughton will be on the air using this special event callsign on August 12.

**GB4RAF:** The station will be manned at RAF Stanbridge on September 1.

**GB50RAF:** This time, the callsign will be on the air from September 1 to 11 from RAF Coningsby.

**GB0RAF:** The station will be on the air from the Lincoln Hamfest over the weekend of September 8/11.

**GB50BOB:** Also on the air over the weekend of September 8/11, this station will be at Hawkinge Battle Of Britain

Museum. The original BOB station ran from 10 July 1940 to 31 October 1940. This was the period for which the Rosette to Air Crew Europe Star was awarded.

**GB0COE:** This station will be on the air on September 23 providing talk-in for the Centre of England Radio Rally being held at the British Motorcycle Museum near the NEC as well as being on h.f. and v.h.f. for those wishing to contact the station.

**PRACTICAL  
WIRELESS  
PW**

**HAVE YOU SEEN THE  
LATEST EDITION OF  
PRACTICAL WIRELESS?**

**FEATURES INCLUDE: BUILD YOUR OWN DESK-TOP MICROPHONE,  
WAVECOM DECODER/ANALYSER REVIEW, VALVE TECHNOLOGY,  
PACKET RADIO UPDATE, COMPETITION CORNER, DAYTON HAMFEST REPORT FROM  
THE USA AND LOTS, LOTS MORE...  
ON SALE AT YOUR LOCAL NEWSAGENT NOW!**



# RALLIES

## \*Short Wave Magazine and Practical Wireless in attendance.

**\*July 29:** The Scarborough ARS Rally will be held at the Spa, Scarborough. Doors open at 11am. Many trade stands, large Bring & Buy, Morse exam and demonstration for the Morse examiners, refreshments and bar. Details from **Ian G4UQP (QTHR). Tel: (0723) 376847.**

**July 29:** The Rugby ATS will be holding their Car Boot Sale at Lodge Farm, Walcote, near Lutterworth, Leicestershire. Talk-in will be provided by GB8CBS on S22. Pitches are £5 for the whole day, entrance for visitors is 50p per car. Gates open at 10am. **David G4DDW. Tel: (0455) 552599.**

**\*August 12:** Hamfest '90 will be held at the Flight Refuelling Sports Grounds, Wimborne, Dorset. The event will feature Radio and Electronics Trade Stands, Craft & Gift Fair, Bring & Buy, a vintage wireless exhibition and full family entertainment. Talk-in on S22. Gates open at 10am. Free parking and overnight camping on the Saturday night by prior arrangement. **John G0API. Tel: (0202) 691649 or Rob G6DUN. Tel: (0202) 479038.**

**August 12:** The 1990 Derby Mobile Rally will take place once again at Lower Bemrose School, St Albans Road, Derby, just off the A511 Derby Ring Road. Gates open at 10.30am with all the usual attractions including the Giant Junk Sale. **Kevin Jones G4FPY, 20 Pinecroft Court, Oakwood, Derby DE2 2LL. Tel: (0332) 669157.**

**August 19:** The West Manchester Radio Clubs Red Rose Summer Rally will be held at the Bolton Sports and Exhibition Centre, Silverwell Street, Bolton.

**August 19:** The Royal Forest of Dean Radio Rally will be held at Speech House on the B4226. It will be a day out for all the family with a jazz band, magician, model racing cars, bouncing castle as well as the amateur radio attractions. **G4HZT. QTHR.**

**August 26:** The Three C's Rally will be held at the Tiddenfoot Leisure Centre, Linslade, Leighton Buzzard, Beds. Entrance fee is £1, children free. **A Perkins. Tel: (0582) 33885.**

**August 26:** The Open Day of the Galashiels & District ARS will be held at the Focus Centre, Livingstone Place, Galashiels. There will be trade stands, a Bring & Buy, catering and all the usual activities. Talk-in on S22.

**August 27:** The Huntingdon Junk Sale & Auction will be held at the Medway Centre, Coneygear Road, Huntingdon, Cambs. Doors open from 10am to 4pm, food and drink will be available all day. **G1YVS. Tel: (0836) 611025 or (0487) 830212 (eves).**

**\*September 2:** The Telford Rally will be held at the Raquet and Exhibition Centre in Telford. Doors open at 11am (10.30 for the disabled). There will be a hundred stands selling radio, TV, computer equipment and antennas, a flea market and refreshments.

**September 9:** The Vange ARS will be moving the rally this year to The Laindon Community Centre, Aston Road, Laindon, Basildon, Essex. Doors open from 10am to 4.30pm with admission at 50p. The rally will include many traders, a Bring & Buy, refreshments and free raffle. Talk-in on S22. **Doris Thompson. Tel: (0268) 552606.**

**\*September 9:** The Lincoln Hamfest will be held in the Exhibition Centre, Lincolnshire Showground. Gates open at 10.30am (10am for the disabled) and the rally closes at 5pm. All the usual trade stands will be there, along with the real ale bar. There will be lots of attractions for the whole family too. Caravans welcome by prior arrangement. Talk-in on S22 by the West Lincs RAYNET Group. **Sue Middleton. Tel: (0522) 531788.**

**\*September 15:** The 1990 Scottish Amateur Radio Convention will be held at Cardonald College, Glasgow. There will be free parking for hundreds of cars, the college dining hall will be open as well as snack bars, there's a licensed bar, three exhibition halls as well as all the usual amateur radio attractions. Doors open at 11am (10.30am for the disabled) with the admission at £1.50. **Tom Hughes. Tel: 041-427 0122.**

**\*September 16:** The British Amateur Radio Teledata Group annual rally will be held at Sandown Park Exhibition Centre, this time in the larger Surrey Hall. **Peter Nicol G8VXY. Tel: 021-453 2676.**

**September 16:** The Bristol Radio Rally will be held in Brunel's Great Train Shed, Temple Meads Station, Bristol. All the usual traders will be there, a large Bring & Buy, food and refreshments as well as displays and demonstrations. **D.S. Farr. Tel: (0272) 839855.**

**September 22:** A QRP Convention beside the Sea will be held in The Garnham Centre, United Reform Church, Back Chapel Lane, Gorleston, Great Yarmouth. Talk-in from 1315 on S22. Prize for the longest traveller and best home-brewed gear, big display of home-brewed QRP gear, light refreshments. Open from 1400-1730 (clocktime). Admission free. **G3OEP, QTHR.**

**\*September 23:** The Centre of England Amateur Radio Rally will be held at the British Motorcycle Museum, Bickenhill,

near the NEC. There will be a Bring & Buy, over 60 trade stands all in three large exhibition halls. There are concessionary rates for all who wish to visit the Museum and ample free parking. Doors open at 10.30am. Admission £1, concession for RAIBC members and Senior Citizens. Talk-in from GB0COE from 7.30am on S22. **Frank Martin G4UMF. Tel: (0952) 598173.**

**September 23:** The Peterborough Mobile Rally will be held in the Werrina Sports Stadium, Peterborough from 10am to 5pm. All the usual traders will be there, a Bring & Buy and tables may be hired on the day (space permitting). Talk-in is on S22 and SU22 by G3DQW. **Robert Maskill. Tel: (0836 542630) any evening.**

**September 30:** The 6th North Wakefield RC Rally will be held at Outwood Grange School, Potovens Lane, Outwood, near Wakefield. Admission is 50p at 11am - disabled 10.30am. Fully licensed bar with real ale, good selection of food from cafe, raffle, Bring & Buy, radio, computer and electronic traders and repeater groups. **Richard G4GCX on (0532) 622139.**

**\*October 7:** The Great Lumley Amateur Radio & Electronics Society will be holding their annual rally in the Community Centre, Great Lumley, near Chester-le-Street, Co. Durham. Doors open at 11am (10.30am for disabled). **Barry G1JDP. Tel: 091-388 5936.**

**October 14:** Computercations will be held again this year at Hillhead campsite on the Dartmouth road in Brixham, South Devon. **Bill Trezise. Tel: (0803) 522216.**

**October 20:** The G-QRP Club Mini Convention will be held in St Aiden's Church Hall, Manchester Road, Rochdale from 10am to 5pm. There will be a large social area, full lecture programme, equipment display, refreshments, Bring & Buy, Component/Kit Stands, Test Bench and lots more. Admission £1. **Rev George Dobbs G3RJV, QTHR.**

**\*October 20/21:** The 4th North Wales Radio Rally will be held at the Aberconwy Centre in Llandudno. The doors open at 11am on both days and the entrance fee is £1 with OAPs 50p and children under 14 free. **Mr B Mee. Tel: (0745) 591704.**

**\*October 26/27:** The Leicester Amateur Radio Show will again be held in the Granby Halls, Leicester.

**\*November 18:** The Bridgend Annual Amateur Radio Rally will be held in the Leisure Centre, as last year. However, for this year they are taking over the whole of the building to make more room! **Don Chennell GW4DUY. Tel: (0656) 863084.**



# ARE

COMMUNICATIONS  
THE SHOP WITH THE SMILE

WE SELL ALL WELL-KNOWN BRANDS  
LET US QUOTE FOR YOUR CHOICE  
KENWOOD — ICOM — STANDARD

**PHONE 081-997 4476**

IC-R100 Ours come with SSB capability, USB/LSB 500kHz-1800MHz

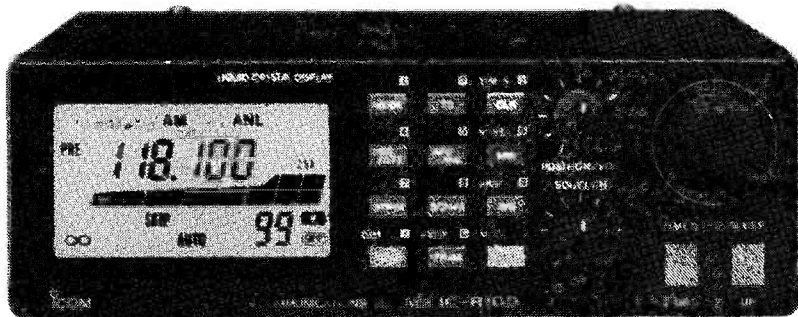

**£499**  
inc. VAT

**IC-R100 Mobile/Base Receiver**

For the enthusiast who prefers a more permanent installation the IC-R100 is ideal giving full frequency coverage of 500kHz-1800MHz and AM/FM. FM wide modes of operation. The IC-R100 boasts 100 memory channels to store your favourite stations and has features similar to the little pocket receiver.  
48 monthly payments of £16.77

**IC-R1 Handportable Receiver**

The new IC-R1 is a pocket-size receiver with continuous 150kHz through 1300MHz, AM/FM and FM wide reception. With 100 memory channels this tiny receiver is packed full of features: Multi-scan functions, 11 search step increments, clock timer, power-save, S-meter and a convenient frequency selection via the keypad or tuning knob.  
36 monthly payments of £16.03

**NO DEPOSIT!  
UP TO 4 YEARS  
TO PAY**

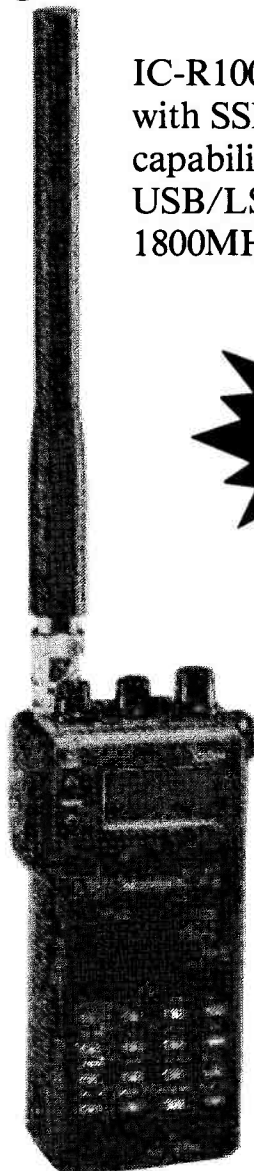

**£399**

**ICR700HF Receiver 500kHz-2GHz**



**ICR700HF Receiver 500kHz-2GHz**

YES, 500kHz to 2GHz CONTINUOUS receive in one unit. Using the ICR7000 multimode facilities, this probably makes the "2 in 1" ICR7000HF Receiver the most versatile scanner available today. Because of the enormous frequency coverage, the ICR7000HF has 200 mode sensitive channels for increased flexibility.

**NO DEPOSIT**

Now available on super credit terms.  
48 monthly payments of £33.23 APR 29%  
Cash/cheque/credit card price  
**£989**



Opening Hours Monday-Friday 9.30 to 5.30  
NOW OPEN SATURDAY 10.00-5.00pm

ARE Communications Limited, 6 Royal Parade  
Hanger Lane, Ealing, London W5A 1ET, England  
Tel: 081-997 4476 Fax: 081-991 2565



# SCANNING

Alan Gardener

## New Products

The JIM PSU-101 consists of a small base unit with a sloping support designed to cradle the scanner, whilst at the same time inclining it at an angle making the display easily readable and the controls immediately accessible. The unit also powers the receiver and charges its internal NiCads permitting continuous operation as a base station - it also keeps the batteries topped up ready for hand-held use. The unit is built to UK safety standards and is suitable for use with the Jupiter II, AOR AR-1000, Fairmate HP-100E and Bearcat 50/55XLT models - the price? £26.

Contact:- Nevada, 189, London Road, North End, Portsmouth, Hants PO2 9AE Tel: Portsmouth (0705) 662145 for further details.

## PRO-2004/2005

The PRO-2004/2005 search and store module I mentioned in the June 1990 column is now available in the UK. Just to recap - the circuit fits inside the receiver and is activated by pressing the 'down arrow' key. In operation the unit automatically stores active frequencies found during a search into a bank of 10 temporary memory channels. This means that you can leave the scanner running unattended and on your return see which frequencies have been active.

A slightly more expensive version offering storage of up to 255 frequencies is also available. The sole UK agent for the module is:- B S Sutherland, 336, Charlton Road, Bristol BS10 6JZ send an s.a.e. or tel: Bristol (0272) 500742 for more information. The price of the 10-channel SS45 unit is £30 and the 255-channel PS 90 £40. For those of you who don't fancy fitting the unit yourself an installation service is available for a small additional fee.

On the subject of the PRO-2005 news reaches me that the model is to be discontinued in the US and will be replaced by a new model the PRO-2006. No further information is available at this stage but I would think that the new model must have some fairly interesting features in order to replace the 2005 so soon after its launch.

## Icom IC-R100

ARE communications are now offering a modified version of the new Icom IC-R100 mobile scanner. In its unmodified form the receiver has a frequency range of 500kHz to 1800MHz and can receive a.m., n.b.f.m. and w.b.f.m. signals. ARE add an extra circuit board to the scanner making it possible to receive s.s.b. signals.

From the outside the scanner looks

**A whole crop of scanning goodies this month starting with a very handy combined stand, charger and mains power supply designed specifically for use with hand-held scanners.**

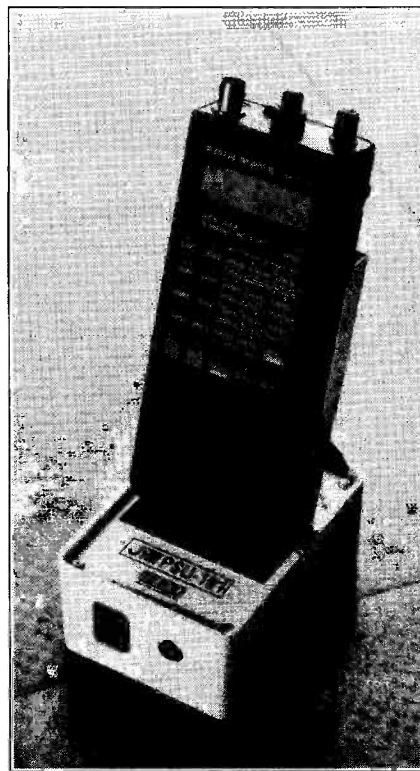

The Fairmate HP-100E hand-held scanner sits neatly on the newly released JIM PSU-101 base unit.

just the same as a normal R100 but by selecting a.m. and pressing the a.n.l. button the new circuit is activated. The receiver still tunes in 1kHz steps on the main dial but the squelch knob now doubles as a fine tune control making it possible to receive either u.s.b. or l.s.b. signals.

This modification really does open up a whole new world as far as short wave reception is concerned as most transmissions other than those from broadcast stations use types of modulation which can only be resolved on a receiver fitted with an appropriate s.s.b. detector stage.

I found the modified scanner to be very sensitive on the short wave bands with several long distance stations being heard with just a short length of wire connected to the antenna socket. Plugging in a full size antenna did create some problems with intermodulation

products masking weak signals. However this was almost certainly due to the receiver being primarily designed for mobile operation. This necessitates a high gain r.f. amplifier stage in order to compensate for the short antennas that are likely to be used under such conditions. Putting a 20dB attenuator between the full sized antenna and the receiver worked wonders - the noise level dropped and quite weak signals became perfectly audible.

This really does increase the versatility of the receiver, so if you are thinking about buying an IC-R100 strongly consider this version. For further details contact: ARE Communications Ltd, 6, Royal Parade, Hanger Lane, Ealing, London W5A 1ET or tel: 081-997-2565.

## AOR AR-3000

The mystery of the additional switch on the microprocessor control board in the AR-3000 has been solved - it alters the baud rate on the RS232 port allowing operation at 9600 bauds instead of the factory-set 4800 baud rate. Useful to know if you want to control the receiver from a computer and need to speed up the rate of data exchange. My thanks to reader **Roy Tait** for this information.

## Scanner Detector Vans?

**Jeff Whiting** of Uxbridge was interested in the comments I made in the June column regarding illegal listening. He wonders if it is possible for the authorities to electronically detect if a scanning receiver is being used to monitor 'sensitive' frequencies and if such equipment exists.

I must say that this is quite an interesting question Jeff - you may be surprised to hear that it is possible and that a fleet of suitably equipped vehicles already exist although they are not used for the purpose you had in mind. They are in fact TV detector vans and before you check to see if this is the April edition let me explain how this is possible.

Most modern radios and TVs use the same technique to receive signals. Incoming signals are mixed with an internally generated signal produced by a circuit known as the local oscillator (l.o.). These signals combine to produce a fixed intermediate frequency (i.f.). The i.f. stages amplify the signals before they are passed on to the detector stage where they are converted to audio. A further a.f. amplifier stage then boosts the low level audio signals up to a suitable level to drive the loudspeaker.

The circuit we are interested in is the l.o. stage. This has to operate at a frequency either above or below the received signal, the difference between the two being the i.f.



# SCANNING

If you know the receiver i.f. and whether the l.o. operates high or low of the received signal then you can monitor the l.o. frequency and check to see if the scanner is in use. The distance that l.o. is detectable over is dependent on several factors but with suitable equipment a range of over 50m could be achieved.

This is the principle that the TV detector van operates on. The job is made easier by the fact that most TV receivers use a standard i.f. at around 39MHz. So if you want to find out which TV channels are being viewed near you why not try the following experiment.

## Vision Carrier

Turn on your TV and tune into one of the local stations. Find out its vision carrier frequency - you can look it up in the 'Antenna' section of a Maplin catalogue. Add 39MHz to the frequency and enter it into your scanner. You may have to tune up or down a bit to detect the l.o. signal but you should hear it. Try changing the channel on the TV, does the signal disappear? If it does the scanner was tuned to the right frequency.

Did you notice any modulation on the signal? Most TV l.o. circuits are not very stable in terms of frequency so a tuning signal is fed to the oscillator from the detector stage in order to keep the receiver 'locked' onto the incoming signal. This correction signal known as automatic frequency control (a.f.c.) usually has a small amount of detected signal superimposed upon it which in turn modulates the l.o. signal. This can usually be detected by selecting f.m. on your scanner. In the case of a TV signal all you will hear is a 50Hz buzz corresponding to the frame synchronisation pulses of the vision signal, listen to the pitch of the buzz change when the picture alters in content. This combined with the l.o. frequency is enough to demonstrate that a TV signal is being received and which channel is being watched.

## Panoramic

Modern TV detector vans use a receiver with a panoramic frequency display. In this way the operators don't have to keep on retuning the receiver, they can simply pick out the l.o. signals as they pass by each house. The van also has an electronic distance logging system fitted so that the source of each signal can be recorded as the vehicle moves.

If you want to experiment a little further why not try listening for the l.o. signals from f.m. stereo tuners. Most of these use an i.f. of 10.7MHz and have the l.o. high of the received frequency. So find a local f.m. broadcast frequency add 10.7MHz and enter it into the scanner. Use f.m. and tune around a little - you

may hear a muffled version of the broadcast signal. This is caused by the a.f.c. circuit modulating the l.o., on the other hand modern synthesised tuners are much more stable in terms of frequency than older designs and don't require a.f.c., so the effect may not be apparent.

You may find that you can't hear the weak l.o. signals because another broadcast station is on the same frequency - but you can try this trick. Tune to harmonics of the l.o. frequency - in the case of the f.m. broadcast band the 2nd and 3rd harmonics fall in the u.h.f. aircraft band which is nice and quiet! Also any modulation present on the l.o. signal is doubled for the 2nd harmonic or trebled for the 3rd harmonic. If the tuner is not particularly mechanically stable you may find that any loud noises vibrate the tuning components and modulate the signal. I know, for example, that if I play a loud record on my hi-fi the sound waves from the speakers modulate the l.o. signal from my stereo tuner and by listening to this signal on my scanner I can tell which track is being played. Mind you it has to be so loud that you can hear it half way down the street! - but it does demonstrate the phenomenon.

## Surprised

Why not try it with other receivers - try the 47-50MHz band. Most receivers here use an i.f. of 10.7MHz with the l.o. operating at around 36-39MHz. If you have a scanner in your car leave it searching over this band whilst you drive around. I bet that you will be surprised at the number of devices you detect. The signals will tend to be much weaker than those from TV receivers or f.m. tuners because they generally do not have external antennas connected. As well as helping to receive signals antennas also tend to radiate the l.o. signals over a

much greater distance. This is because the l.o. signal tends to leak through the receiver's r.f. amplifier stages to the antenna socket. If you want to pick out really weak l.o. signals you need a scanner capable of receiving s.s.b. This increases the detection range to several hundred metres.

This technique can be applied to almost any receiver - including scanners! Models using a high 1st i.f., like the Tandy PRO-2004/2005 (610MHz), AOR AR-2001/2002 (750MHz), Jupiter II (705MHz), Fairmate HP-100/AOR AR-1000 (251.575 or 561.225MHz), Icom R-7000 (778.7 or 266.7MHz) and AOR AR-3000 (736.23 or 352.23 or 198.63MHz). All of these have a fairly high power l.o. operating in the same frequency band as those in u.h.f. TV receivers - so in theory it would be possible to use the same detection equipment to track down either type of equipment. A scanner l.o. is particularly distinctive as it sweeps up and down in frequency very rapidly if the search or scan functions are in use.

## Espionage

This method of detecting a receiver and determining its operating frequency has applications beyond just tracking down scanning receivers. It is a technique well known in counter espionage circles where it may be necessary to know if the 'other side' is listening to you - listening to them!

I hope that this has answered your question Jeff and has given readers something new to monitor with their scanners.

If you have any items you would like to contribute such as operating tips or modifications or have any questions you would like an answer to - why not drop me a line at P.O. BOX 1000, Eastleigh, Hants SO5 5HB. Until next month - Good listening and watch out for those detector vans! □

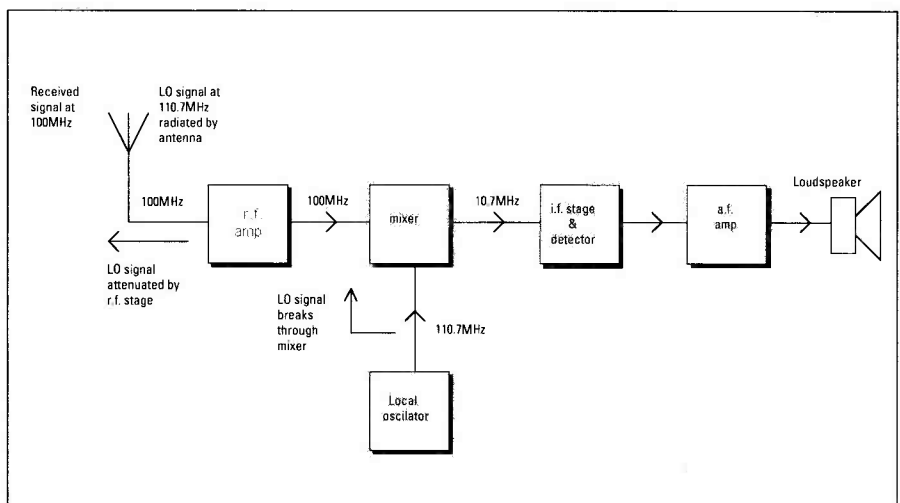



# PLEASE QSL

P.E.W. Allely GW3KJW

I have been receiving and sending QSL cards for over 30 years and have never understood why I persist in what I consider to be a foolish and costly business.

Why do we do it? What makes us participate in such madness?

I can only suggest that it is a feeling of inadequacy with our log books, a desire to have tangible evidence of our achievements, a talking point and a trophy to exhibit.

The history of QSL cards is fairly well documented, although the early cards, unfortunately, have largely been destroyed along with such valuable documents as log books. The original reason for them was valid early transmitting engineers were uncertain that their signals were being received and requested written confirmation of reception.

Additionally, bureaucratic systems required confirmation in writing, a habit still used. How many times have you telephoned an order and later confirmed it in writing?

This commercial and military practice was adopted by the early radio amateurs for principally the same reasons, i.e., they weren't quite sure that they had, in fact, established two-way communication and were writing to confirm the contact.

Short wave listeners were pursuing the exchange of QSL cards for an equally sensible reason. They were writing to distant broadcast stations informing them that their programmes were being received, and there is no doubt at all that the content and scheduling of programmes on overseas transmissions was very much influenced by such reports.

**"Many thanks for the QSO old man, please QSL. 73".  
How many times have you heard this? How many times have you said it? Does the other person mean it? Do you?"**

## Halcyon Days

During the halcyon days of amateur radio, before the commercialisation of the hobby took place, QSL cards were sent that contained a wealth of information. Details of the transmitter and receiver (usually in the form of a valve line-up) were sent, together with a detailed description of the antenna in use at the time. Very often full details of weather and band conditions were included giving the recipient an insight of propagation conditions prevalent at the time of the contact.

Such cards were, as now, generally displayed on the shack wall, a habit very much in vogue, although with modern technology, the cards are no longer pinned to the wall, but enclosed in expensive, clear plastics, display envelopes.

Unfortunately today's QSL card contains very little useful information. It gives a report, but surprisingly few people receive a report these days of 3 + 3 or 219x., invariably it will be in the range of 5 + 5 to 5 + 9. These QSL cards seem to concentrate on describing the relative wealth of the amateur in terms of transceiver, amplifier and antenna manufacturers.

The cards themselves are very often

brilliantly designed, high class, gloss finished masterpieces, but are also, occasionally, what I and my family consider to be pornographic. Perhaps I am old-fashioned, but that's the way I am.

It seems a pity that some who one has spent a fortune buying and sending their QSL cards should describe a 'YAGI' as a 'YARGI', or should write in a manner which would bring shame on a seven-year old.

If I am in contact with some one and we exchange reports giving each other a readability report of 5, we have informed each other that we are both fully readable. What's the point of written confirmation by post? Again, if after many attempts due to poor conditions, to obtain all the details, and I succeed, I do not need a card reiterating all that I have been told.

## Awards

"But what about claims for awards?" I hear you ask.

Well, what about them? I steadfastly refuse to send for any awards which require proof of contacts by the production of QSL cards. If I say I have worked someone that's the end of it. If I made a false claim, the only person I am really fooling is myself. I have received certain awards but instead of bundles of QSL cards, I have sent an extract from my log book, signed by a fellow amateur to the effect that it is a correct copy. If everyone refused to send cards, this foolish demand would be dropped.

There is a certain psychological pressure placed upon us to send cards, this manifests itself most obviously in the trite phrase 'The final courtesy of a QSO is a QSL', which I have seen printed often on cards. What nonsense.

## Abusing the Hobby

Perhaps the saddest thing is to receive a QSL card advertising some commercial product. We are really abusing the hobby in this fashion, this is not a new idea, but unfortunately it is now tied up with so-called Special Event Stations that are often blatantly advertising a commercial enterprise.

A friend of mine, a very well known v.h.f. and u.h.f. enthusiast, living on an elevated site, does not QSL at all, and has the greatest difficulty in persuading people not to send cards to him. One day, during good tropo conditions and in a pile-up, I heard him say in desperation to one amateur who insisted on sending him a card, "Well if you must send one, make it a matt card, they burn better than the glossy ones."

I quite understood his feelings, after all what do you really do with the cards. My collection resides in shoe boxes in



This QSL card was received by your Editor while operating GB2PW on 14MHz RTTY in November 1981 on the *Practical Wireless* stand at Breadboard 81.



# PLEASE QSL

my desk, there are none on display.

Yes, I do send cards, I enjoy receiving worthwhile ones and reply to every card I receive if it is a genuine contact. Unfortunately, living in a comparatively rare location I occasionally receive cards for contacts I have not made. These cards are destroyed, but I will send out approximately 1000 cards a year. There is a growing tendency, especially on h.f., for certain amateur stations to designate some one as their QSL manager and to ask for so many IRCs and self-addressed envelopes. This incurs additional expense and makes a mockery of well established QSL Bureaux. Not only that, but I sometimes receive s.s.a.e.s from UK amateurs requesting my QSL card for a contact made on v.h.f. or u.h.f. Return postage, say 40p, cost of card 3p, cost of envelopes, 5p. Total cost 48p for one card. You could join the RSGB twice over for the cost of a 100 Square Award and use the QSL Bureau to boot.

## Ultimate Foolishness

Finally, the ultimate foolishness - the QSL collection of pirate. Being extremely naive, I did not appreciate that CB operators, in fact, sent QSL cards until

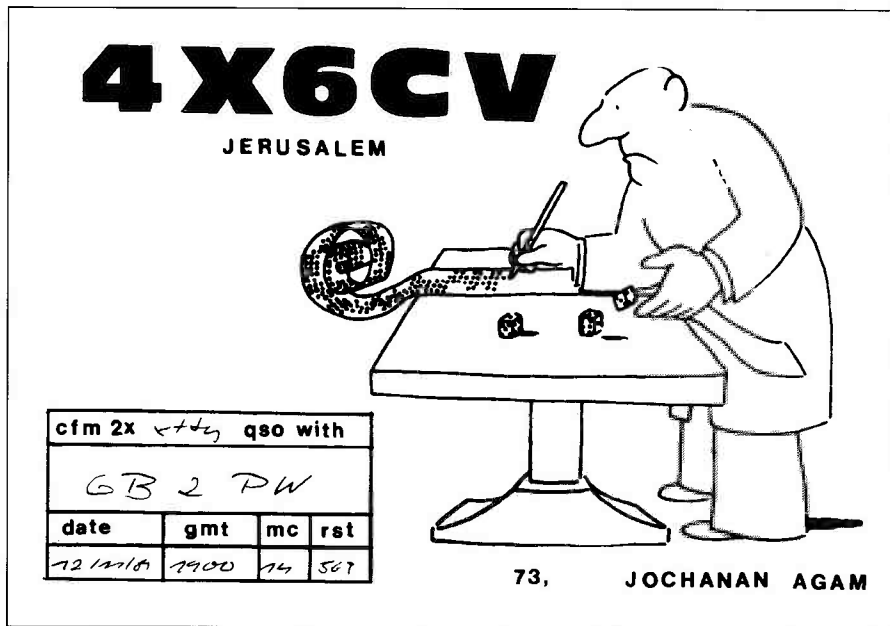

cfm 2x $\leftarrow$ $\rightarrow$ qso with			
GB 2 PW			
date	gmt	mc	rst
12/1/85	1900	14	567

one day I was shown the shack of such an operator. There, displayed on the wall, was a large and impressive collection of foreign QSL cards. Closer examination showed that all of them were for s.s.b. contacts on 27MHz.

I could not comprehend the mentality that possessed someone not only to break the law, but to produce for all to see the

evidence of such illegalities. Imagine denying illegal operation, using a *nom-de-plume*, and a Post Office Box Address, then shooting yourself in the foot.

Perhaps the best way, if we must persist in sending and receiving these pretty pieces of paper, is to say that we will QSL only on receipt of a card, and then only via a bureau.

## SHORT WAVE MAGAZINE DELIVERED TO YOU EACH MONTH TAKE OUT A SUBSCRIPTION TODAY!

Fill in the Order form below and post it to: PW Publishing Ltd., FREEPOST, Subscriptions Dept., Enefco House, The Quay, Poole, Dorset BH15 1PP (no stamp required). Credit Card Orders taken on (0202) 645524.

Overseas subscriptions outside Europe are now despatched by Accelerated Surface Post for faster delivery.

If you already have a subscription you can still take advantage of our offer, but you must quote your subscription number.

Please indicate the type of subscription required

### SHORT WAVE MAGAZINE 1 YEAR

- £19.00 (UK)  
 £21.00 (Europe)  
 £22.00 (Rest of World)

### PRACTICAL WIRELESS 1 YEAR

- £19.00 (UK)  
 £21.00 (Europe)  
 £22.00 (Rest of World)

### SPECIAL JOINT SUBSCRIPTION 1 YEAR

- £32.00 (UK)  
 £35.00 (Europe)  
 £37.00 (Rest of World)

Prices current at July 1990

To commence with issue dated.....

To: PW Publishing Ltd., FREEPOST, Subscriptions Dept., Enefco House, The Quay, Poole, Dorset BH15 1PP

Name.....

Address.....

I enclose cheque/PO (Payable to PW Publishing Ltd) £.....

Charge to my Access/Visa Card the amount of £.....

Card No.

Valid from ..... to .....

Signature.....



# COMMUNICATIONS

**BEARCAT SCANNERS**  
 Recently appointed as the UK distributors for this high quality product range — we offer the complete selection of mobile and base scanners with full service back up.

**BEARCAT HANDHELD SCANNERS**

- UBC 50XL** (10 CH MEM.) ..... £99.95  
 (66-88 MHz, 136-174 MHz, 406-512 MHz.)
- BC 55 XLT** (10 CH MEM.)..... £99.95  
 (29-54 MHz, 136-174 MHz, 406-512 MHz)
- UBC 100XL** (16 CH MEM.) ..... £179  
 (66-88 MHz, 118-174 MHz, 406-512 MHz.)
- UBC 100XLT** (100 CH MEM.) ..... £199  
 (66-88, 118-174, 406-512 MHz.)
- UBC 200 XLT** (200 CH MEM.) ..... £229  
 (66-88, 118-174, 406-512, 806-956 MHz.)

**BEARCAT BASE SCANNERS**

**UBC 175 XLT (16 CH. Memories)**  
 An economical base scanner covering all the popular aircraft, marine and public service bands. Coverage 66-88, 118-174, 406-512 MHz ..... £169.99



**BEARCAT 760XLT**

**New Model with 900MHz Coverage**  
 With 100 memory channels and coverage of the UHF band, the 760XLT is ideal at home or in the car. Pre-programming of preset bands is possible for fast access. Freq. Coverage 66-88, 136-174, 406-512 MHz. ... £235  
 806-956 MHz

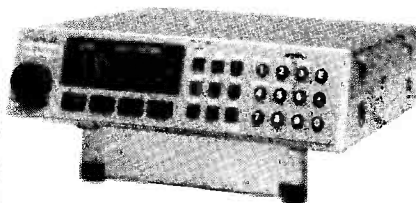

**UBC 145 XLT (16 CH. Memories)**

A low cost base scanner suitable for marine and public service reception  
 Coverage 66-88, 136-174, 406-512 MHz .. £115

The 100 XLT and 200XLT handhelds feature removeable battery packs for easy charging - and have proved popular because they are simple to operate giving excellent performance and reliability.

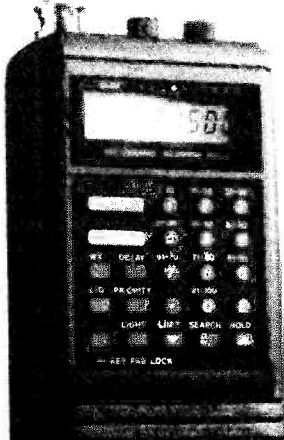

**SONY RADIOS**

We are the main short wave stockist  
**Sony ICF SW1E** Short Wave + VHF, world's smallest s/wave radio ..... £149.95



- Sony ICF 2001 D** (150kHz -136MHz) . . . £299.95
- Sony ICF 7600 D** Pocket s/wave s/hand. .... £99
- Sony Air 7** airband h/held..... £229
- Sony Pro 80** wideband h/held..... £199
- Sony AN1** active antenna..... £49

**COMMUNICATIONS RECEIVERS**

- Low HF225** (30kHz-30MHz) . . . . . £429
- Kenwood R2000** (150kHz-30MHz)  
 10 memories..... £595
- Kenwood R5000** (100kHz-30MHz)  
 100 memories..... £875
- ICOM R71E** (100kHz-30MHz)  
 32 memories..... £855
- ICOM R9000** (100kHz-2GHz)  
 1000 memories... £3995

**LOW NOISE PRE-AMPLIFIERS**

For base and handheld scanners.

- 25—2100 MHz
- Low noise GaAs FET
- Selectable filters for improved performances
- Variable Gain Control

These new Pre-Amplifiers are a must for the scanner enthusiast and will allow reception of signals that were inaudible without them.

**MODEL M50**

A new low cost pre-amp without filters or gain control. Offers low noise GaAs FET at 20 dB fixed gain..... £49.95



**MODEL M100**

Same spec as M75 but with full RF switching, may be used with transceivers on transmit up to 5 watt o/p power ..... £79.95

**MODEL M75** (see spec. above)

For base and mobile scanners (supplied with PP9 battery)..... £69.95



**Nevada Communications**  
 189 London Road  
 North End  
 Portsmouth  
**HOTLINE**  
**(0705) 662145**  
**FAX (0705) 690626**  
 DISTRIBUTORS OF RADIO COMMUNICATIONS EQUIPMENT WITH DEALERS THROUGHOUT THE UK & EUROPE

# STOCKIST OF SCANNING RECEIVERS

## BLACK JAGUAR MkIII

Independantly tested by a European magazine, the Black Jaguar was found to be the most sensitive handheld scanner on the market! That probably explains why it is still so popular. Features include 16 channel memories, selectable AM/FM and the facility to power the set from the mains/car using one of the many accessories now available. Covers civil and military airbands plus lots more!  
Frequencies: 28-30, 50-88 MHz, 115-178 MHz, 200-280 MHz, 360-520 MHz. **£199**



## BLACK JAGUAR ACCESSORIES

- (SUITABLE FOR ALL MODELS, BJ200, CHALLENGER ETC.)
- Mobile Mount ..... **£6.95**
  - Base Mount ..... **£5.95**
  - BJ1 Car Supply (Mk111 version only) ..... **£14.95**
  - BCA6 Mains Slow/Fast Charger ..... **£14.95**
  - Airband Rubber Duck Ant ..... **£6.75**
  - SA7 UHF Stub Antenna ..... **£5.95**
  - Telescopic Antenna ..... **£6.75**
  - BCA3 Mobile Antenna Charger ..... **£14.95**

## AOR SCANNERS

**AR 3000** wideband scanner 100kHz to 2036MHz with no gaps! Now available. **£765**

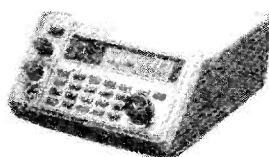

- AR 2002** popular base scanner with coverage 25-550 MHz, 80-1300 MHz and 20 memory channels ..... **£487**
- AR 950** new low cost base with 900 MHz UHF band ..... **£249**

## MASTHEAD ANTENNA SWITCH

For Scanning Enthusiasts select 2 antennas at the masthead remotely from one cable.  
Frequency: DC to 1.3 GHz  
Connectors: 'N' Type ..... **£49.95**

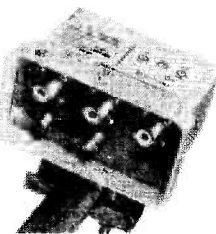

## ICOM

**NEW**

We are ICOM specialists and carry the complete range in stock including these **NEW** models:-

**IC-R1** The new miniature wideband handheld scanner that covers 150 kHz to 1300 MHz with 100 memories and many features. **£399**



**IC-R100** Mobile or base extra wideband scanning receiver covering 500kHz to 1.8GHz with 100 memory channels and reception of AM, FM, WFM ..... **£499**

**IC-R72** A new HF communications receiver covering 100kHz to 30MHz. Receivers SSB/AM/CW with FM board as optional extra 99 memory channels and 10dB pre-amp fitted as standard ..... **£645**

**IC-R7000 ICOMS** Most popular communications receiver. Covers 25 MHz to 2 GHz with 99 memories and all mode reception ..... **£925**

Call Paul our ICOM specialist for details of other ICOM amateur radio products we stock - or for details of the latest models and prices.

## STANDARD AX700

The first scanner to feature a panoramic display covers 50-905 MHz with 100 memory channels ..... **£575**  
Supplied with free wideband discone antenna worth £59

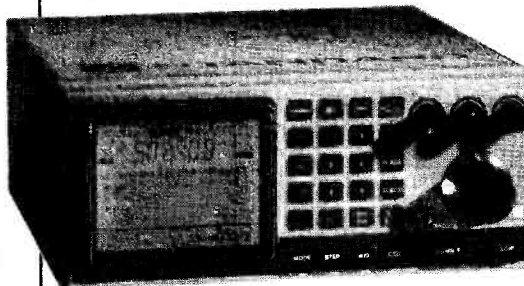

## LOW LOSS JAPANESE COAX

Essential for optimum performance with wideband UHF scanners. We have directly imported this cable which has exceptional low loss and is good for frequencies up to 3 GHz. Loss at 1 GHz for 10 mtrs is 1.3 dB - 8D.



MODEL 8D (11.1mm) ..... **£1.40** per MTR

## SCANNING ANTENNAS

- Nevada WB 1300 discone** (25-1300 MHz) Stainless steel top of the range. .... **£59.95**
- CTE Micro Scan** (180-1300 MHz) New low cost ground plane .... **£12.00**
- CTE Sky Band** (25-1300 MHz) Stainless Steel Discone ..... **£24.00**
- Nevada Mobile Antenna** (50-1300 MHz) Magnetic Mount ..... **£27.90**
- Create Wideband Beam** (105-1300 MHz) 20 Element ..... **£89**

## ASA DIGITAL AIRBAND RADIO

This new low cost receiver is designed for aviation enthusiasts featuring a digital display for accurate reception and tuning. Coverage: 85-108MHz FM, 118-136MHz AM, 162-165MHz weather, 520kHz-1.6MHz ..... **£59.95**



## UNIVERSAL SCANNER BASE UNIT PSU101 MkII

Allows convenient use of your handheld scanner at home. A mains operated unit which will both charge and power the handheld scanner. Complete with convenient desktop stand for use at home. Suitable for the following models:- Fairmate HP100E, AOR 1000, Jupitar II, ICOM 1C-R1, Uniden BC 50XL, Uniden BC 55XL, Uniden BC 70XLT, Realistic PRO 38, Uniden 200 XLT, Uniden 100 XLT. **£26**

## FAIRMATE

As the UK distributor for Fairmate we are constantly working with them to update and produce new features and models.

### FAIRMATE HP100E MkII

1,000 channels memory, 8-600MHz, 805-1300 MHz. .... **£249**

### FAIRMATE HP100E Special Model WB1

A new limited edition version with extended frequency coverage: 1-600 MHz, 805-1300 MHz... **£289**

### FAIRMATE HP100E

Base charger/adaptor stand. Also suitable for AOR1000, Jupitar II etc. Charges and powers the radio whilst allowing use at home. .... **£26**

See our colour adverts elsewhere in the magazine for full details.

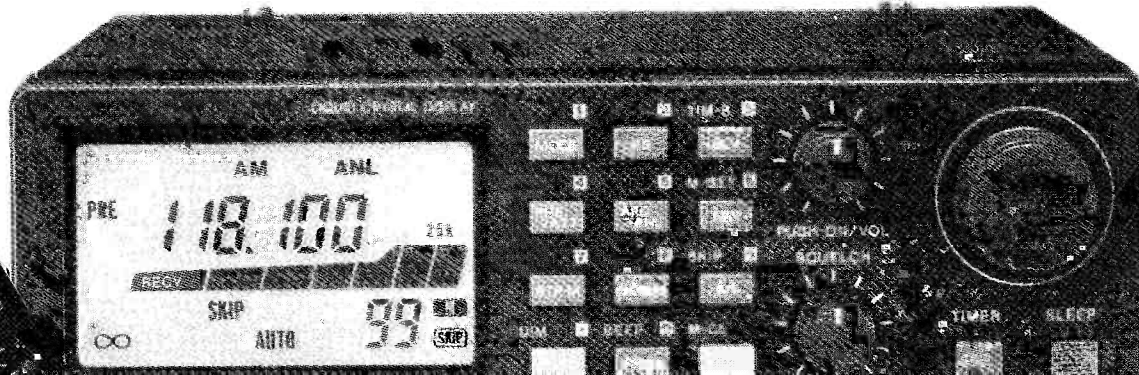



# AIRBAND

Godfrey Manning G4GLM

Occasionally there is a misunderstanding about radar services outside regulated airspace. The radar service (information or advisory) is additional to the pilot's eyes; it is not a controlling service - after all, the flight is outside of any regulated airspace in the first place. What happens when the aircraft approaches controlled or special rules airspace, then?

Well, as **Alan Jarvis** (Cardiff) has found out, it's entirely the pilot's responsibility to recognise the approach to a controlled zone and to make the appropriate contact with air traffic control in good time.

The radar information/advisory service will not formally hand the flight over to the next controller; instead the jargon now in use is that the pilot should 'free call' the next controller, i.e. with no controller-to-controller liaison on the land-line. This could also apply to other non-coordinated transfers between controllers.

## Search & Rescue

Search and rescue Nimrods were of interest to **John Garnett** (Truro, Cornwall) in the June edition. Let me recommend the *Rescue* book which I reviewed in July. The *RAF Flight Information Handbook* also gives frequencies. Edinburgh and Plymouth Rescues use 5680kHz; at night 3023 and 3085kHz are possible although initial calls are still made on the day frequency. There is also 5695kHz.

Maritime distress frequencies are 500 and 2182kHz; 8364kHz is used by survival craft. Of the Nimrods only one is on 24 hour rescue standby at any one time. Callsigns 01-16 are used in the Northern Sector by fixed-wing rescue aircraft and 51-65 in the Southern Sector. 'Nimrod 51' would be on routine patrol in the South, 'Rescue 01' could be a Nimrod actually during rescue duties in the North. Contributors to this information were **Chris Coates** (North Walsham, Norfolk); **Paul Hilton** (Newbury, Berkshire); **Pat Martindale** (Bridlington, Yorkshire); **R.A. de Savigny-Bower** (Ruislip, Middlesex); and **Dick Ware** (Gillingham, Dorset).

## Follow-Ups

Thanks **Sean Carvin** EI2CR (Dublin) for locating GIBSO at the UR8/UR14 intersection (May 'Airband'). Sean will remember corresponding with me over navigational matters long before 'Airband' came in to existence.

That extra dot (letter E in Morse) on some n.d.b. idents (June 'Airband') is explained by **Geoff Halligey** (Bridgend, Mid-Glamorgan), retired from BEA, and R.A. de Savigny-Bower (also a pilot) and Dick Ware. The equipment is installed in pairs - normal and standby. When the E (for emergency) is heard, the standby

**Something for everyone!  
Search & Rescue Nimrods  
and where to obtain official  
information are just two of  
the topics covered by  
Godfrey this month.**

transmitter has been switched in. To add complication, certain continental beacons use plain carrier which is keyed off and on to produce Morse but is otherwise present continuously (unkeyed) to provide a direction-finding signal. A.b.f.o. is required to produce audible tones in the receiver. Does the beacon pointer on the r.m.i. wander around during the keying of the carrier?

To Geoff, a plea for more reminiscences about riding the ranges; I don't have access to the suggested source material from the Croydon Society.

In May I asked for the London Mil frequency, found in the *RAF Flight Information Publications* by **Stephen Hill** (Warwick) as 262.8MHz.

Also in May was a request for the location of the Grantham transmitter of Eastern Radar. **Fran Kelk** (Nottingham) finds that she lives in the same area since the antennas are at Croxton Park and, if I've read it correctly, Lewstern. This is not in the place north of Grantham suspected by **P.J. Salisse** (Highgate, London).

Back to April and **P.M. Yorke** (Camberley, Surrey) clarifies that SelCal tones are transmitted in two pairs, each member of one pair being sent together.

## Technical Questions

**Colin Frowen** (Burgess Hill, West Sussex) has a Grundig YB-700 and wants to connect a random long wire to it. If the receiver is equipped with a socket for an external antenna then the best advice would be to make the connection via an a.t.u. A bought or built a.t.u. will be quite cheap if specified for receiving only, rather than transmitting purposes.

What does the CAA building in Little Budworth, Cheshire, do? Donald Sandwell (Huddersfield) would appreciate the answer if any local readers would write in.

Another callsign query is Stud, from **Ken Marsh** (Southport). I, too, read about this somewhere but can't recall the answer. Help, anyone, please.

How can one service appear on a frequency meant for another? **Godfrey Raivid** (London, NW4) is worried by this.

One possibility with superheterodyne receivers is that the signal isn't really on the frequency to which the set is tuned. If it is twice the i.f. away, then it could be image (second channel) breakthrough.

## Information Sources

New reader **H.T. Wood** (Abingdon, Oxfordshire) wants the usual sources of official aeronautical information publications. Although I am unable to reply to individuals directly I am pleased to be able to publish the information here in this column.

\* 1 AIDU, RAF Northolt, West End Road, Ruislip, Middlesex HA4 6NG. (Tel: 081-845 2300 X209).

\* Aerad Customer Services, Building 254, PO Box 10, London (Heathrow) Airport, Hounslow, Middlesex TW6 2JA (Tel: 081-562 0795).

\* Jeppesen products can be ordered through the Oxford Airport Shop, Oxford (Kidlington) Airport, Kidlington, Oxfordshire OX5 7RA (Tel: (0865) 841234, note the new number).

\* Jeppesen's West German address is: Jeppesen & Co., Kaiser Strasse 77, 6 Frankfurt/Main 16, B.R.D.

\* The Godfrey Manning Aircraft Museum. If desperate for a particular item of really urgent information, and if all the usual sources have failed; also, to book an appointment to visit; telephone 081-958 5113 on a weekday evening 18:00-22:30 local time.

A reader in West Glamorgan particularly wants the German address. He also points out the useful Concorde routes chart in *Air Traffic Control* by **Graham Duke**, a book I reviewed last month.

The communications section of the *Aerad Supplements*, for example, will help **Keith Phillips** (London, W.12) to elucidate the channel pairings between v.o.r. frequencies (actually tuned in by the pilot) and TACAN/d.m.e. channels (automatically selected by the receiver once the v.o.r. frequency is set).

Stephen Hill will find company frequencies listed in the *VHF/UHF Airband Frequency Guide* by **Bill Laver** and published by Waters & Stanton. You can buy this useful book by mail order from the *SWM Book Service* - full details and prices on page 58 of this issue.

**Chris Hasman** (N52°24' W0°50') wants a list of ICAO airport designators and I recommend the *Aerad Supplement*. Chris suggests a get-together by readers to swap ideas.

Last year I put forward another reader's suggestion that perhaps we could meet at certain airshows or radio events but there were no takers. Is anyone else out there interested in a specific meeting this year?

Don't forget the West Malling Show on August Bank Holiday Monday - **Dave Lawrence G6HXR** (Snodland, Kent) certainly won't, especially as it could well be the last one. By the way, good luck with the Morse, Dave.

# THE COMPANY THAT BRINGS YOU THE LATEST TECHNOLOGY - FIRST !

SALES HOTLINE 021 552 0073 and HELPLINE 021 552 0051 (Office Hours)

## ANOTHER RAYCOM PACKAGE

The **TOKYO HX240** HF Transverter when coupled to an all-mode 2m rig will give you 50W on 80 to 10m. RAYCOM have put together this unique unit with the new YAESU FT290RII.

**IT WORKS GREAT !**

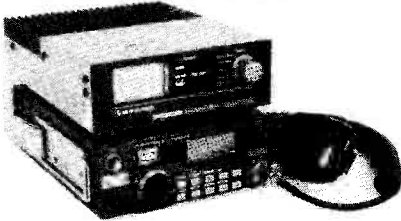

FT290R II ..... £429.00  
 TOKYO HX240 ..... £249.00  
 1/2 Size G5RV ..... £ 14.95  
 12 Amp PSU ..... £ 59.95  
 Nicads & Wall Charger £ 31.30  
 Total regular price .... £784.20

RAYCOM PACKAGE .. £699.00

**YOU SAVE £85.20 !**

Includes ALL D.C. and Co-ax leads

**EXCELLENT HF AND VHF STARTER PACK  
 COME IN AND TRY IT FOR YOURSELF - YOU  
 WILL NOT BE DISAPPOINTED**

FULL RANGE OF YAESU AND ICOM ALSO STOCKED

## HP100E/AR1000

**Exclusive to RAYCOM  
 Short wave converter Module**

Made in the UK by AKD

Coverage 200kHz to 30MHz

HP100E with converter £299.00

HP100E no converter £249.00

Converter only ..... £ 59.00

**NOTE**

HP100/AR1000 not purchased from RAYCOM requires modification to work with the converter. Cost £15.00

## THE UK SCANNER EXPERTS

**WE HAVE SECURED LIMITED QUANTITIES OF THE NEW ICOM SCANNERS  
 DIRECT FROM JAPAN - HURRY TO RESERVE YOUR ONE NOW!**

### The FANTASTIC ICOM ICR1 and ICR100

IC-R1 500kHz to 1300MHz ..... £399.00  
 IC-R100 500kHz to 1800MHz ..... £499.00

### OTHER HIGH QUALITY SCANNERS FROM RAYCOM

BEARCAT UBC 50/55XL 66-88/136-174/406-512MHz ..... £99.95  
 10 memories, channel review, including FREE charger worth £4.95  
 BEARCAT BC 70XLT 66-88/136-174/406-512MHz ..... £149.99  
 20 memories, full frequency display, with FREE car charger kit worth £4.50  
 BEARCAT UBC 100XLT 66-88/118-174/406-512MHz ..... £199.99  
 100 memories, airband, search, including FREE car charger kit worth £4.50  
 BEARCAT UBC 200XLT 66-88/118-174/406-512/806-956MHz ..... £229.99  
 200 memories, top of the range, including FREE car charger kit worth £4.50  
 BEARCAT UBC760XLT 66-88/108-174/350-512/806-956MHz MOBILE .... £229.99  
 100 memories, 5 search bands, including FREE mains adapter worth £4.95  
 NEW JUPITER MVT 6000 mobile ..... ONLY £329.00  
 25 to 550 MHz and 800 to 1300MHz, 100 Memories  
 JUPITER MVT 5000 Hand-held ..... ONLY £249.00  
 25 to 550MHz and 800 to 1300MHz, 100 Memories  
 AOR 3000 base ..... Limited Supplies available £699.00  
 0.1 to 2036 MHz, 400 mems, LSB/USB/CW/WFM/NFM/AM

**MANY OTHER TYPES AND MODELS STOCKED - NEW AND USED.**

SEND AN SAE FOR OUR LATEST USED LIST

URGENTLY WANTED - USED SCANNERS AND HAM GEAR, WORKING OR NOT.

## ICOM IC-R7000



Listen to weather, fire, coastguard, TV, airband and many, many more. Wide frequency coverage provides you with all the channels you need to become a VHF and UHF listener. Frequency coverage is guaranteed from 25 to 1300MHz, but may extend on individual units to 2GHz! Features include:

- USB, LSB, FM, FM-N, AM
- 99 memory channels, keypad entry
- optional infra-red remote control
- variable speed scan and delay
- optional voice synthesizer
- six tuning steps
- sensitivity < 0.3µV for 10dB SINAD

**Save £108! Raycom price £925**

Including FREE Royal 1300/AH7000 25 - 1300MHz discone complete with co-ax and plugs.

## CHARGE IT!

Why not take advantage of the **RAYCOM Credit Card** and spread the payment for that scanner you've always wanted. Example: Yaesu FRG9600 MKV package £70 deposit and £28 per month (APR 36%). Call for a quote and written details! Licensed credit broker.

## YAESU FRG9600



9600 standard 60-905MHz ..... £469.00  
 9600 MkII 60-950MHz ..... £499.00  
 9600 MkII pack 60-950MHz .. £545.00  
 9600 MkV 0.2-950MHz ..... £625.00  
 9600 MkV pack 0.2-950MHz .. £699.00  
 Standard to MkII .. Upgrade £ 40.00  
 Standard to MkV .. Upgrade £149.00  
 MkII to MkV ..... Upgrade £129.00  
 Packs include PSU and ROYAL 1300!

RAYCOM COMMUNICATIONS SYSTEMS LIMITED, INTERNATIONAL HOUSE, 963 WOLVERHAMPTON RD, OLDBURY, WEST MIDLANDS B69 4RJ. TEL 021-544-6767, Fax 021-544-7124, Telex 336483 IDENTI G.

**RAYCOM**

COMMUNICATIONS SYSTEMS LIMITED

Telephone 021 - 544 6767

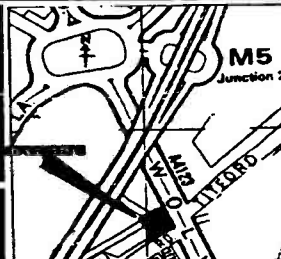

**RAYCOM gives you more BUYING POWER**

ALL MAJOR CREDIT CARDS ACCEPTED. BC, ACCESS, DINERS. INSTANT CREDIT UP TO £1000 (SUBJECT TO STATUS) WITH RAYCOM CREDIT CARD (APR 36%). INTEREST FREE CREDIT ON CERTAIN ITEMS AT MRP. CALL FOR MORE DETAILS.

**ORDERING INFORMATION**

WE STOCK ICOM, YAESU, BEARCAT, MFJ, BUTTERNUT, CUSHCRAFT, AEA, NAVICO, STANDARD, TEN-TEC AND WELZ AMONG MANY OTHERS. SEND SAE FOR FULL LIST.

**TEL: 021-552-0073**

PHONE BEFORE 4PM FOR NEXT DAY DELIVERY BY COURIER (£15.00) OR 2PM FOR DELIVERY BY POST (£10.00). PLEASE ALLOW TIME FOR CHECKS TO CLEAR. MANY OTHER ITEMS IN STOCK. PLEASE CALL FOR MORE INFO AND FOR EXTRA SPECIAL DEALS!

INFOLINE 0836-771500 5-9pm (weekdays)

OPENING HOURS 9-5.30 MON TO SAT, 73 DE RAY GAKZH, PETER, GAEWD COLIN and JOHN on the phone.



# AIRBAND

## Frequency & Operational News

Our regular look at the Civil Aviation Authority *General Aviation Safety Information Leaflet 5/90* corrects previous information for West Malling; the Tower frequency of 130.875MHz should remain unchanged. Also, Oxford has reverted back to 119.8MHz. Both of these appeared in the June 'Airband.' Note that Alderney changes from 123.6 to 125.35MHz.

In the nav aids department Fenland has a new n.d.b. (FNL) on 401 as has Ottringham (OTR) on 398.5kHz. The latest frequencies in the attempt to avoid French interference are Henton 395 and Westcott 335kHz. You can locate nav aids by plotting the published lat/long on an Ordnance Survey map (being careful to note that the National Grid lines are not parallel to lat/long lines) and this technique enabled Alan Jarvis to locate the Radnor n.d.b. in mid-Wales. He took its photo to prove it! Let me know, Alan, if you wish the photo to be published here.

This year the big Fighter Meet display at North Weald used 127.5MHz rather than the standard aerodrome frequency.

Colin Frowen notes that Brest 134.875MHz relays Brest Sector 133.0MHz providing continuous coverage from southern England to Madrid on one frequency!

Stephen Hill says that the RAF sources warn of unauthorised ground stations

giving instructions to aircraft working Amsterdam. How strange! I can't explain why Sculthorpe is listed on 148.25MHz but there have been a few out-of-band spot frequencies for a long time.

On to Royal Marines helicopter frequencies: I can't help, Stephen, as my old (1984) *Helicopter Landing Sites* doesn't list them. Lastly, air-to-air North Atlantic communications are allowed on 131.8MHz.

**Anne Reed RS87871/G-20126** (Cheltenham, Gloucestershire) wants me to put frequency updates in the column. As you see - I do!

Anne rumours that Upper Heyford may close and considers it a shame; the gliding fraternity, limited by the Upper Heyford Mandatory Radio Area, will disagree. I'll stand back and refuse to join in the argument, so as to live to write another column next month!

You have been so prolific with your letters that I'm sorry if there wasn't room for all the points raised this time.

The next three deadlines (for topical information) are August 3, September 7 and October 5. All correspondence to Godfrey Manning, c/o SWM Editorial Offices in Poole please. □

Abbreviations	
a.t.u.	antenna tuning unit
BEA	British European Airways
CAA	Civil Aviation Authority
b.f.o.	beat frequency oscillator
d.m.e.	distance measuring equipment
ICAO	International Civil Aviation Organisation
i.f.	intermediate frequency
kHz	kilohertz
MHz	megahertz
nav.	navigation, navigational
n.d.b.	non-directional beacon
RAF	Royal Air Force
r.m.i.	radio magnetic indicator
TACA	TACTical Air Navigation
u.h.f.	ultra high frequency
v.h.f.	very high frequency
v.o.r.	very high frequency omni-directional radio range

## Tidy up that pile of mags!

### SWM BINDERS Only £4.50 each

(plus £1 p&p for one binder, £2 p&p for two or more, UK or overseas)

Are you tired of sifting through cardboard boxes and carrier bags to find that useful item in SWM?

Our smart binders, covered in blue plastics, are a must for your library, keeping your radio magazines in good condition and easily accessible.

### Plus!

Tidy up those other mags too. Plain binders to take any A4 size magazines - no names, no pack drill !!!

### HOW TO ORDER

Send a postal order, cheque or international money order with your order stating number and type required to **PW Publishing Limited, FREEPOST, Enefco House, The Quay, Poole, Dorset BH15 1PP.**

Payment by Access, Mastercard, Eurocard or Visa also accepted on telephone orders to Poole (0202) 665524. Normally despatched by return of post but please allow 28 days for delivery.

Prices include VAT where appropriate.



  **0202 665524 (24 hour Answer Service)**



# The New Cirkkit Summer Catalogue

- 100s new products
- £10 worth discount vouchers
- Latest books
- Low cost multimeters
- 184 pages
- Only £1.60 available from larger newsagents or directly from Cirkkit



**Cirkkit Distribution Ltd.**

Park Lane, Broxbourne, Herts EN10 7NQ  
Telephone (0992) 444111

**OUT NOW! OUT NOW! OUT NOW!**

## TURBO-CHARGE YOUR SCANNER !!

Do you own an **R7000**, **FRG9600** or **AR2002**?

Why not upgrade your Scanner into a professional monitoring station with the **SCANMASTER** remote control unit from E.M.P. Ltd

**SCANMASTER** plugs into the 'Remote' socket on your scanner and takes over its operation and hence greatly expands the facilities and functions available.

**SCANMASTER** is like a T.N.C. in that you supply it with 12 volts D.C. and talk to it with a terminal via its RS232 interface.

**SCANMASTER** can be left stand-alone for un-attended monitoring.

**SCANMASTER** is in constant use by many 'official' organisations.

**SCANMASTER** has many powerful and easy to use features such as:

- Over 700 memories available.
- Remarks can be assigned to memories.
- Parallel Printer Interface for hard copy output.
- Real Time Clock for time/day logging.
- Frequency offset button for split channels.
- Signal strength logging via A/D.
- Squelch relay output for switching tape-recorder On/Off.
- Versatile search facility.
- Extensive User Manual.
- And many more features.

**Special Price (UK) .....£149.99 including Postage & Packing.**

28 day money back guarantee if not entirely satisfied. When ordering, please state which scanner you have.

**E.M.P. Limited . 51 High Street . Portland . Dorset . DT5 1JQ . Tel (0305) 826900.**

Despatched by return of post (subject to availability).

Main Dealer: Garex Electronics. Tel: (0364) 72770 Fax: (0364) 72007.

Dealer Enquiries Invited





# GRUNDIG YACHT BOY 220

John Bird

There are many portable radios available today ranging from the very basic and limited performance types that you find at the local market through to advanced communication receivers. So the question must be - where does the Grundig Yacht Boy 220 fit in?

Despite its small size the Yacht Boy features nine short wave bands, besides the normal m.w., l.w. and v.h.f. coverage.

The power requirements are three AA size batteries that fit in a conventional compartment on the bottom of the radio. For those who prefer to use an external power source, there is a standard coaxial connector on the side panel that would accept 4.5V d.c.

The antenna system comprised an internal ferrite rod for l.w. and m.w. reception, while the short wave and v.h.f. bands use the 560mm telescopic whip antenna. When not in use the whip folds flush with the top of the receiver.

With the continuing trend for personal listening, there was a standard 3.5mm jack on the side panel for the connection of headphones. This would accept both stereo and mono headphones, though of course the output was mono only. As is normal practice, the internal speaker is disabled when using headphones.

There are a couple of other features that enhance the portability of the Yacht Boy. The first is a wrist strap that is secured to the receiver via a universal joint to prevent the strap becoming tangled. The second is a rather smart padded carrying case. This is great for use when travelling, as it affords a good degree of protection.

## Operation

Grundig have gone to great lengths to keep the operation of the Yacht Boy as simple as possible. The most important

**There is always a boyant market for small, portable short wave receivers and a recent contender in this class is the Yacht Boy 220 from Grundig.**

control, tuning, took the form of a conventional rotary type using a 26mm knob on the side panel. The frequency readout comprised an analogue dial and pointer system with each band having its own scale. All the dial markings were in kHz or MHz and the scale length was 41mm. The reduction drive is just about right for this type of scale, requiring three full turns of the tuning knob to traverse the dial.

With a separate scale for each band, a system for showing the selected band is necessary. This is done using a l.e.d. below each scale that illuminates to show the current band in use.

Push button controls are employed for band selection and volume control. These comprised two rocking buttons on the front panel. Increasing or decreasing the volume was simply a case of pressing either the + or - side of the control. Similarly changing bands means pressing the band button marked < and >.

The only controls not yet covered are the on/off, which is a conventional slider, and the tone switch. The tone switch is on the side panel and has three tone options. The middle position gives an unweighted response whilst the lower gives a certain amount of bass boost to provide a more pleasing sound when

listening to music. The final position is specifically for speech broadcasts and limits the bandwidth at both ends of the spectrum.

As you can see from this description, operation of the Yacht Boy was very straightforward and included all the important extras.

## In Use

Before spending time tuning around I made a few measurements to check out a few of the basic performance parameters. One thing that can be extremely irritating when using analogue tuning dials is inaccuracies in the dial calibration. So my first test was to check the dial on the Yacht Boy. I was very surprised, and pleased, with the result. The technique I used was to set the dial to the centre of a marked frequency, connect a signal generator and adjust the generator for spot-on tuning. The signal generator output frequency was then measured with a digital frequency counter.

Using this method I found that the maximum error was 50kHz at 9.5MHz, an error of only 0.5 per cent! This is really very impressive for a receiver of this type. The great advantage of an accurate dial is that known stations can be found much more quickly.

This level of accuracy was apparent throughout the frequency range including the v.h.f. band. However, measurement of the dial accuracy on v.h.f. was complicated by the automatic frequency control that locked over a wide range.

For the next tests I looked at the sensitivity of the Yacht Boy. I started with the short wave bands, which perhaps are the most demanding. The sensitivity turned out to be between 1 and 2µV for 10dB S/N throughout the nine bands. This again was a very creditable performance. The only other sensitivity measurement was on v.h.f. where a result of 4µV was obtained, which is perfectly adequate.

As the Yacht Boy had a tuning indicator in the form of a l.e.d. that glowed to show optimum tuning, I measured the signal level required before this became operative. This turned out to be between 15µV and 20µV depending on which band was selected.

From a technical viewpoint these tests show the Yacht Boy to be a very competent receiver.

## Acid Test

With the technical tests complete I set about the acid test of listening on air.

For best sound quality, v.h.f. is the obvious choice. The Yacht Boy performs well producing a sound quality that is a credit to its 42mm 0.5 watt speaker. On

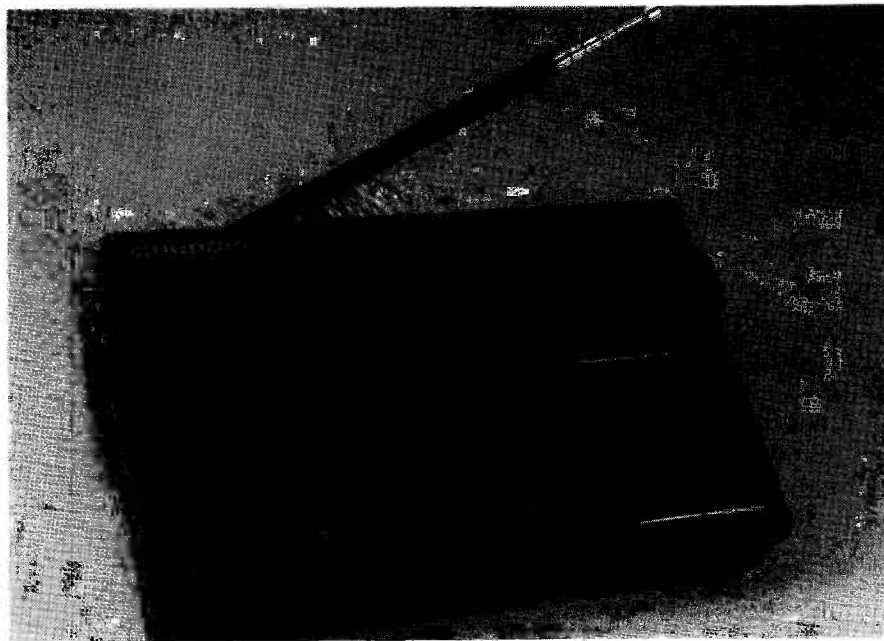

# GRUNDIG YACHT BOY 220

v.h.f. the bass boost of the tone control was particularly effective.

The short wave performance was very good and lived up to the expectations from the technical tests. My best result from a DX point of view was Radio Pakistan though I did manage many other stations, including Radio Moscow. It was whilst on the short wave bands that I made good use of the speech position of the tone control. This very effectively minimised interference such as whistles and growls that can ruin the intelligibility of many transmissions.

The medium and long wave

performance was much as expected with no problems experienced on local or long distance reception.

## Summary

I must admit I was surprised by the technical performance of this very tiny receiver. The dial accuracy was truly remarkable and an area where some of the competition shows very badly. The sensitivity is another important area that has been well addressed by Grundig. Besides its technical achievement, Grundig have also managed to keep the

ergonomics well under control to produce a very pleasing design.

Overall then, the Yacht Boy 220 is a very good example of the modern small portable radio and should prove to be very popular. As well as a useful second receiver for those of us who travel a lot it would also provide a good introduction for the beginner.

The Grundig Yacht Boy 220 is available from most Grundig stockists at around £59.95. My thanks to Grundig UK for the loan of the review model. □



## Specification

Frequency Range	VHF	87.5 - 108MHz
	MW	515 - 1630kHz
	LW	140 - 290kHz
	SW1	3.9 - 4.0MHz
	SW2	5.95 - 6.2MHz
	SW3	7.1 - 7.3MHz
	SW4	8.5 - 9.9MHz
	SW5	11.85 - 12.05MHz
	SW6	13.6 - 13.8MHz
	SW7	15.1 - 15.6MHz
	SW8	17.55 - 17.9MHz
	SW9	21.45 - 21.85MHz

Output Power	0.5 watts peak
IF	10.7MHz and 455kHz
Power Supply	Three IEC H6/UM3/AA
External Mains Unit	4.5V d.c. NR30-75

## SERVICES

### Subscriptions

Subscriptions are available at £19 per annum to UK addresses £21 in Europe and £22 overseas. Subscription copies are despatched by Accelerated Surface Post outside Europe. For further details see the announcement elsewhere in this issue. Airmail rates for overseas subscriptions can be quoted on request. Joint subscriptions to both *Short Wave Magazine* and *Practical Wireless* are available at £32 (UK) and £37 (overseas).

### Components for SWM Projects

In general all components used in constructing SWM projects are available from a variety of component suppliers.

Where special, or difficult to obtain, components are specified, a supplier will be quoted in the article.

The printed circuit boards for SWM projects are available from the SWM PCB Service. See page 26 for full details.

### Back Numbers and Binders

Limited stocks of most issues of SWM for the past ten years are available at £1.65 each including P&P to addresses at home and overseas (by surface mail).

Binders, each taking one volume of the new style SWM, are available price £4.50 plus £1 P&P for one binder, £2 P&P for two or more, UK or overseas. Please state the

year and volume number for which the binder is required. Prices include VAT where appropriate.

Orders for p.c.b.s, back numbers, binders and items from our Book service should be sent to **PW Publishing Ltd., FREEPOST, Post Sales Department, Enefco House, The Quay, Poole, Dorset BH15 1PP**, with details of your credit card or a cheque or postal order payable to PW Publishing Ltd. Cheques with overseas orders must be drawn on a London Clearing Bank and in sterling.

Credit card orders (Access, Mastercard, Eurocard or Visa) are also welcome by telephone to Poole (0202) 665524. An answering machine will accept your order out of office hours.



# USING A SOLAR RADIO TELESCOPE

Ron Ham  
Part 4

During 1980 I recorded periods of continuous solar noise each month with the exception of August. 'Tone-A' radio signals were heard between 1500 and 2100 on January 27 and ionospheric disturbances were reported by World Service over the following three days. Henry Hatfield logged solar noise at 1296MHz during the storm on February 2 and 3 and bursts of noise were heard at 50MHz while the storm was in progress on February 10, 12 and 13.

A blackout took place on h.f. when the solar noise was 'off scale' on April 7 and very large bursts manifested at 50MHz on the 11th and 28MHz on the 28th. Ionospheric disturbances were reported by World Service on October 5 and 12 and Henry logged solar bursts around 210MHz on days 1, 14, 22, 23, 25 and 30 and again during the storm on November 1, 2, and 3. At 1124 on October 9, Henry, using his spectrohelioscope, saw a triple flare inside a six-spot group and, 16 minutes later, he began to record radio noise at 136MHz. Faint aurora was reported from an observer in Scotland on November 19 and 23 and a larger event was tracked by 'tone-A' radio signals at 1900 on December 19. The latter was followed by an ionospheric disturbance reported by World Service on the 20th. The radio noise from the sun was really severe with the recording pen off scale on the 26th and as the sun began to set, a profile of the South Downs, at the rear of my home, was again drawn on the recording chart.

## Declining

Although the sunspot cycle was declining during the early 1980s, I recorded solar storms, on 143MHz, in February, March, April, May, July, August, September, October, November and December, 1981 and I learnt from colleagues, that solar noise was also heard on 28MHz in February, August and September and that aurora, recognised by 'tone-A' signals, manifested on March 5, April 13, July 25, August 18, October 15, November 11 and December 29.

**Ron concludes the story of his home-built radio telescope with the years from 1980 to 1984 when the equipment was finally dismantled.**

Auroral reflected signals were exchanged on 144MHz between stations in southern England and Scotland on April 13 and a massive blackout occurred on April 27. No doubt there were more but I heard the BBC World Service report ionospheric disturbances on February 27, April 23 and September 20. During the year, Henry Hatfield experimented with a second instrument running at 198MHz and he recorded noise at this frequency in March, April, May, July and August.

During 1982, I recorded solar noise at some time during each month except for May and while the severe storms in January and February were in progress, Henry Hatfield logged the noise at 198MHz. The noise was also heard at 28MHz in February, June and July. Aurora manifested at 1915 on February 1, 1530 and 0300 on March 1 and 2 respectively, 1800 on July 13 until early on the 14th, midday and most of the afternoon on September 6 and at 1800 on the 26th, 1445 on November 24 and 1750 on the 29th and at 1740 on December 10.

1983 was relatively 'quiet' and although I recorded storms in February, March, April, May, June, July, August, September and October, the number of individual bursts received during the year was well down. While the February storm was in progress Henry Hatfield often recorded noise at 197MHz in addition to his normal working frequency of 136MHz. Aurorae manifested at 1915 on the 4th, 1407 on the 6th and 1500 on the 12th.

For some years several of us had an arrangement that as soon as aurora was sighted, or radio signals developed a 'raspy' tone we telephoned our nearest

colleague and the 'grapevine' began. There is little doubt that this storm was caused by the six sunspot groups, one with about 20 spots, seen by Henry with his spectrohelioscope on the 2nd.

The activity from the two small groups with a long chain of about 20 spots and an eruptive prominence, which Henry observed on March 5, was responsible for the noise on the 7th and 9th and the aurora on the 12th. Solar bursts were heard on 28 and 50MHz on May 16, 22 and 28 and an ionospheric disturbance was reported by World Service at 1330 on the 12th. This was not unexpected because during the previous day Henry logged 3 sunspot groups and 2 flares.

## Noise Storms

Although 1984 was another 'quiet' year, I still recorded noise storms in January, February with severe storms on days 16 and 31, April with 'severe' marked in the log for days 2 to 5 and 16 and 17, May, June, September, November and December. Henry Hatfield received solar noise at 136 and 197MHz on January 31 and bursts were heard in the 28MHz band while the late April storm was in progress.

Aurora was detected by radio on January 4 and 10 and February 26. Henry observed '2 large and very angry spot groups' and the remains of a flare at 1130 on January 31. Patrick Moore reported 'a trail of sunspots' on March 29 and large spots on April 3 and 24.

## The Records Live On

By the end of 1984, I had learnt and written a great deal about radio emissions from the sun and their effect on the paths of terrestrial radio signals. At this point the telescope's antenna and framework, underground cables and some of the electronics had completed over 16 years work and were in need of major repairs so, with some reluctance and a great feeling of satisfaction, I decided to cease regular observation and dismantle the installation.

Printed circuit boards for SWM constructional projects are now available from the SWM PCB Service. The boards are made in 1.5mm glass-fibre and are fully tinned and drilled. All prices quoted in the table include Post and Packing and VAT for UK orders.

Orders and remittances should be sent to: **PW Publishing Ltd, FREEPOST, Enefco House, The Quay, Poole, Dorset BH15 1PP**, marking your envelope **SWM PCB Service**. Cheques should be crossed and made payable to PW Publishing Ltd.

When ordering please state the Article Title as well as the Board Number. Please print your name and address clearly in block capitals and do not enclose any other correspondence with your order. You may telephone your order using Access or Visa. A telephone answering machine will accept your order outside office hours.

**Please allow 28 days for delivery. Only the p.c.b.s listed here are available.**

## SHORT WAVE MAGAZINE PCB SERVICE

Board	Title of Article	Issue	Price £
SR005	R210 Converter	July/August	6.87
SR004	PRO-2004 Modifications	Oct 89	6.63
SR003	HF to VHF Converter	Aug 89	5.22
SR002	Weather Satellite Reception	Jun 88	3.88
SR001	Audio Filter	Jul 87	6.00



Telephone orders: (0202) 665524

# dressler

COMMUNICATIONS LTD.

VISA

AMEX

RSGB

MON.-FRI. 9.00-5.30  
SAT. 9.30-5.00

## DRESSLER ACTIVE ANTENNAS

### ARA 30

ACTIVE ANTENNA  
50kHz...  
40MHz WITH LIMITED PERFORMANCE UP TO 100MHz

Professional electronic circuitry with very wide dynamic range. Meets professional demands both in electronics and mechanical ruggedness. 1.2m long glass fibre rod. Circuit is built into waterproof 2.5mm thick aluminium tube. Ideal for commercial and swl receiving systems. £139. See review in Practical Wireless August 1985 issue p.35. Both antennas come complete with 7 metres of cable, interface, power supply and brackets. **£139**

### ARA 1500

50MHz - 2GHz  
Frequency Gain  
50-1000 11.5dB  
1000-1500 11.0dB

**£159.00**

'N' Connection

Now fully tuneable interface. Intercept point +21dBm Typical.

**191 FRANCIS ROAD  
LEYTON · E10 6NQ · LONDON**  
TELEX 8953609 LEXTON G  
PHONE 081-558 0854 081-556 1415  
FAX 081-558 1298

24hr Hotline ansaphone 081-558 0854  
Or contact your local agent anytime on the following numbers: Stewart (Bromley, Kent) 01-466 5199, 0860 634526, Terry (Biggleswade, Beds.) 0767 316 431.

## YAESU



YAESU  
FRG  
8800

FRG 8800 HF RECEIVER  
**£585.00**

VHF CONVERTER **£100.00**



YAESU  
FRG 9600  
50-950 MHz  
**£500.00**

## KENWOOD

R5000 HF Receiver only... **£799**  
R5000 + ARA 30... **£899**  
RZ1 Mobile scanner 500kHz - 905MHz... **£459**

## ICOM

ICOM R71  
General Coverage Receiver  
**£855**



FIRST CLASS SHORT WAVE RECEIVER.  
BUY THIS FOR **£855** AND RECEIVE AN  
ARA 30 FREE. WORTH **£139**.  
Also R7000 complete with  
ARA1500 **£999**.

ICR9000 150kHz - 2000MHz incl. ARA 30 +  
ARA 1500 and delivery... **£3995**

## SONY

SONY ICF 2001D  
76-108MHz 116-136

AIRBAND  
153kHz-29.995MHz  
FM - AM - SSB 32 MEMORIES  
INC PSU, CARRY STRAP  
& EARPHONE

Complete ICF2001D system including all above,  
plus AN 1... **£349**

Sony AIR7... **£229**

Sony Pro 80-150kHz, 115-224MHz,

AM-FM-SSB... **£299**

Sony AN1 Active Antenna... **£55**

Sony AN3 Airband Antenna... **£53**

SONY SW 7600DS

NEW MODEL ICF-SW/7600DS featuring stereo  
FM+USB/LSB & larger display... **£165.00**

76-108MHz  
153kHz-29.995MHz

Complete with case,  
mains power supply,  
earphone and frequency list.

## STANDARD



STANDARD  
AX700  
PANADAPTOR DeLuxe  
**£575.00**

JRC NRD 525

SPECIAL Price NRD 525 Receiver.  
**£1150 incl. ARA 30 £950 without**

GRUNDIG 500... **£280**  
ICOM R1... **£399**  
ICOM R100... **£499**  
AOR 1000... **£249**  
AOR 2515... **£575**  
AOR 2002... **£459**  
AOR 3000... **£799**

By the time you read this advert the AOR 3000  
should be in stock at £695 not £799.

# Bredhurst

electronics



**BREDHURST ELECTRONICS LTD.**  
High St, Handcross, W. Sx. RH17 6BW  
(0444) 400786

SITUATED AT SOUTHERN END OF M23 — EASY ACCESS TO M25 AND SOUTH LONDON

### RECEIVERS

HF225	£425
ICR71	£855
R2000	£595
VC10VHF Converter	£161
FRG8800	£649
FRV8800VHF Converter	£100
R5000	£875

### HF TRANSCEIVERS

TS950SD	£3199
TS940s	£1995
TS440s	£1138
TS140s	£862
TS690s	£985
FT767GX	£1599
FT757GX2	£969
FT747GX	£669
IC765	£2499
IC751A	£1500
IC735	£979
IC725	£759
IC726	£989

### 2M TRANSCEIVERS

TH25E	£238
TH205E	£199
TH215E	£228
TS711E	£898
TR751E	£589
TM231	£289
FT411 + FNB10	£259
FT290R II	£429
FT211RH	£309
FT212RH	£349
IC2GE	£265
IC228H	£385
IC275E Inc PSU	£1089
IC25E	£275
IC25ET	£295

### 70CMS TRANSCEIVERS

TS811E	£998
TR851E	£699
TH405E	£245
TH415E	£268
TM431E	£318
FT790R II	£499
FT711RH	£349
FT712RH	£375
IC4GE	£299
IC4SE	£310
IC448E	£429

### DUAL BAND TRANSCEIVERS

TM721E	£699
TS790E	£1495
FT470R + FNB10	£384
FT738R	£1199
FT4700RH	£499
IC32E	£399
IC3210E	£499
IC2400E	£635
IC2500E	£675

### SCANNING RECEIVERS

ICR7000	£989
FRG9600M	£509
Icom ICR100	£499
AR2002	£487
RS35 Airband	£249
Standard AX700C	£575

### ANTENNA TUNER UNITS

FRT7700	£59
FC757AT	£349
AT230	£208
AT250	£366
ICAT100	£379
MFJ941D	£116
MFJ949C	£165

### DATONG

AD370 Active Antenna	£77.62	3.00
FL3 Multimode Filter	£145.64	2.00
D70 Morse Tutor	£63.40	2.00
ASP Speech Processor	£93.15	2.00

### COAXIAL SWITCHES

SA450 2way SO239	£19.49	1.50
SA450N 2way N	£26.99	1.50
Drae 3way SO239	£20.18	1.50
Drae 3way N	£26.11	1.50
C54 4way BNC	£30.39	1.50
MFJ-1701 6way SO239	£38.35	1.50

### POWER SUPPLIES

BNOS 12/5E	£74.75	5.00
BNOS 12/20E	£178.25	5.00
DRAE 8amp	£84.99	3.00
DRAE 12amp	£113.10	5.00
DRAE 24amp	£163.42	5.00

### HAND HELD RECEIVERS

RS375 Airband	£69.00	2.00
FAIRMATE HP100E	£249.00	2.00
Win108 Airband	£175.00	2.00
AORAR1000	£249.00	2.00
Yupiteru MVT-5000	£299.00	2.00

### PALOMAR ANTENNA PRODUCTS

Antenna Noise Bridge - Upto 100MHz	£59.95
Tuner-Tuner - Tune your ATU without transmitting	£99.95
LED S.W.R. Meter - Auto SWR up to 2kW	£124.95
P.E.P.	£23.95
9:1 Balun. For the T2FD Antenna.	£23.95

GOODS NORMALLY DESPATCHED WITHIN  
24HRS - PRICES CORRECT AT TIME OF GOING TO  
PRESS - EGOE

MAIL ORDER & RETAIL

### ANTENNA RANGE

J Beam 'Minimax' Triband	£378.35
J Beam TB3MK3 Triband	£365.70
Butternut HF6VX	£182.85
Butternut HF2V	£163.30
Cushcraft A3 Tribander	£329.00
Cushcraft 2M 215WB	£99.00
Tonna 20505 5ele 50MHz	£50.72
Tonna 20009 9ele 144MHz	£33.12
G Whip tribander 10, 15 and 20m	£44.39

### MORSE KEYS

Kent Morse key kits	£33.50	2.50
Kent Twin-paddle kits	£42.50	2.50
Hi Mound MK704	£20.00	2.00
Hi Mound MK706	£22.00	2.00
Bencher BY1 Black Base	£67.42	2.50
Bencher BY2 Chrome Base	£76.97	2.50

### FILTERS

AKD HPF1	£7.65	1.00
AKD Braid Breaker	£7.65	1.00
AKD Notch Filter	£8.75	1.00
AKD High pass filter	£8.25	1.00
LF30A Low pass filter	£32.26	2.00

### ANTENNA BITS

Bricomm Balun 1.1 1kW	£15.26	1.50
Bricomm Balun 4:1 1kW	£16.25	1.50
Bricomm 7.1MHz Epoxy Traps (pair)	£13.65	1.50
Self Amalgamating Tape 10m x 25mm	£4.25	0.75
T-piece polyprop Dipole centre	£1.60	0.25
Small ceramic egg insulators	£0.65	0.20
Large ceramic egg insulators	£0.85	0.20

### CABLES ETC.

URM 67 low loss coax 50ohm per metre	£0.95	0.25
UR 76 50ohm coax dia. 5mm per metre	£0.35	0.10
UR 70 70ohm coax per metre	£0.35	0.10
UR 95 50ohm coax dia. 2.3mm per metre	£0.40	0.10

**BREDHURST ELECTRONICS LTD HIGH ST, HANDCROSS, W. SUSSEX. RH17 6BW (0444) 400786**

Open Mon-Fri 9am-5pm except Wed 9am-12.30pm. Sat 10am-4pm



# CAP.CO

## Another FIRST from CAP.CO — RMA Series Antennas

The FIRST truly complete set-top HF Receiving Magnetic Loop Antenna system designed by G4OGP.

Produced with the Short Wave Listeners in mind, but often used by Amateurs to improve their reception.

The ONLY set-top Antenna system that can be rotated and tilted to eliminate low angle and high angle noise.

RMA - 1 incorporating High-gain Low-noise RF Pre-amplifier coverage 1.8MHz to 8MHz **£79.50**

RMA - 2 Pre-amplifier (without) **£44.50**

In addition, separate wire aerial in external socket allows coverage up to 1.5GHz.

(Postage one Aerial £5.00 — both Aerials £7.50.)

Send SAE for details of our range of Capacitors, ATUs and Magnetic Loop Antennae.

**CAP.CO ELECTRONICS LTD,**  
**UNIT 28, PENLEY INDUSTRIAL ESTATE,**  
**PENLEY, WREXHAM, CLWYD LL13 0LO.**  
**Tel: 0948 74717.**

## JAVIATION VHF/UHF AIRBAND SPECIALISTS 0274-732146



MVT 5000



MVT6000

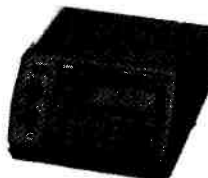

AOR AR2515



AR 1000/HP 100

With equipment from AOR, Fairmate, Yupiter, Icom, Signal, Sony, Unidan Bearcat, Revco, Win, Black Jaguar, Tandy/Realistic and others we offer one of the widest ranges of receivers suitable to the airband enthusiast. For information or advice please give us a call and have a chat or send a large SAE for a catalogue.



Frequency lists. Our UHF & VHF airband lists are produced and amended regularly, enabling us to keep them as up to date as possible. Our VHF list includes LATCC transmitter sites/frequency tie ups, squawk, codes, and the ICAO 3 letter airline decode. Our UHF list is probably one of the most comprehensive available and is updated regularly to keep pace with the changes. — How many have the new Eastern frequencies?



UHF — £2.00  
VHF — £3.00

**AOR900 ACCESSORIES**  
Spare battery packs £15.50  
Robust leather carry cases £25.00

**Second hand:** Our secondhand equipment changes all the time, if you are after a particular set please give us a call — we might have what you are after.

**JAVIATION**  
**CARLTON WORKS, CARLTON STREET, BRADFORD.**  
**WEST YORKSHIRE BD7 1DA**  
**TELEPHONE: 0274-732146 FACSIMILE: 0274-722627**

## BBC WORLD SERVICE SHOP

### WORLD RADIO AND T.V. HANDBOOK 1990

This authoritative encyclopedia guide has long been recognised as the most up to date publication on long, medium and short wave throughout television stations worldwide.

Included in the 1990 edition

- ☞ Satellite radio, and T.V
- ☞ Equipment for radio and satellite reception
- ☞ Computer software for the radio enthusiast
- ☞ Second annual WRTH industry awards for best receivers and software.

Published February 1990. Price £18.99 (Postage included)

### DIAL SEARCH (New edition)

A detailed summary of what appears on long, medium and short wave with an emphasis on the U.K. -Listener Recommended.

Published February 1990. Price £3.99 (postage included)

BBC WORLD SERVICE SHOP  
DEPT SW-FEB  
BUSH HOUSE, SRAND  
LONDON WC2

Allow 28 days for delivery.  
Pay by sterling cheque to BBC  
World or by credit card (quoting  
number & expiry date)

Mon-Sat 10-5 (Holborn or Temple Tube)

Visit the shop for books on shortwave radio satellite T.V. and a range of receivers

# RTTY DATA DECODER PROGRAM

Ian Wraith

This short program, written in BASIC for the Commodore 64 machine converts the five-digit numbers transmitted by the numerous meteorological stations on short wave using RTTY and c.w. into plain English weather information.

Although this can be accomplished without a computer it would take at least 15 minutes for each report and being a tedious operation would be prone to errors. This simple BASIC program will perform the translation in less than 1 second - once the transmitted data has been entered into the computer.

Although the program is written in BASIC for the Commodore 64, it will also run on the VIC 20 and the Commodore 16 and +4 machines. It is also a simple matter to translate it for other computers using BASIC. It has been successfully run on an Amstrad PCW 8256 using Mallard BASIC and the necessary changes are shown below.

**A home computer is the ideal tool to assist in the decoding of the various forms of data received over the air.**

## Data Entry

As an example the following data is typical of that received on short wave.  
AAXX 25124 00001 11475 72913 10069  
20044 49952 58005 60021 72581 83922  
333 10092 81914 83820 84075=  
(Note that only those synoptic reports with the AAXX identifier can be decoded. However, these are by far the most common.)  
RUN the program and the computer will prompt NEXT NUMBER?. Now type in the first group of digits transmitted after

the AAXX ident (2514). Type RETURN and up will come the prompt NEXT NUMBER?. Enter the next group of digits (00001) followed by RETURN and continue this process until all the numbers have been entered.

If the computer continues to ask for the NEXT NUMBER? even after all the numbers have been entered, just type RETURN.

## Output

The printout from the computer when it has completed the decoding is shown in the sample printout reproduced here. The station number indicates the location of the weather station.

The table shows some examples. A full list is included in the *Air & Meteo Code Manual* by Kligenfuss and available from the SWM Book Service price £12.00 plus 75p postage. □

03145	Glasgow Weather Centre
03245	Newcastle Weather Centre
03335	Manchester Weather Centre
03726	Bristol Weather Centre
03778	London Weather Centre
03865	Southampton Weather Centre
03917	Belfast Airport

```
10 REM ** WX DECODER BY IAN WRAITH **
20 PRINT CHR$(147); CHR$(5);: POKE 53280!,0: POKE 53281!,0
30 DIM N$(15)
40 REM ** INPUT DATA **
50 INPUT "FIRST NUMBER"; N$(0)
60 FOR A=1 TO 15
70 INPUT "NEXT NUMBER"; N$(A)
80 IF N$(A)=" " THEN A=A-1: GOTO 70
90 NEXT A
100 REM ** DECODE DATA **
110 PRINT CHR$(147);
120 PRINT "STATION NUMBER:"; N$(1)
130 PRINT "DATE "; LEFT$(N$(0),2); " OF MONTH"
140 PRINT "TIME OF OBSERVATION WAS "; MID$(N$(0),3,2); "00 UTC"
150 PRINT "TOTAL CLOUD COVER IS "; LEFT$(N$(3),1); " OKTAS"
160 PRINT "TRUE DIRECTION OF WIND IS ";: GOSUB 600
170 PRINT "WIND SPEED IS "; MID$(N$(3),4,2); " KNOTS"
180 PRINT "AIR TEMPERATURE IS ";
190 IF MID$(N$(4),2,1) = "0" THEN PRINT "+";
200 IF MID$(N$(4),2,1) = "1" THEN PRINT "-";
210 PRINT MID$(N$(4),3,2); "."; MID$(N$(4),5,1); "C"
220 PRINT "DEW POINT TEMPERATURE IS ";
230 IF MID$(N$(5),2,1) = "0" THEN PRINT "+";
240 IF MID$(N$(5),2,1) = "1" THEN PRINT "-";
250 PRINT MID$(N$(5),3,2); "."; MID$(N$(5),5,1); "C"
260 PRINT "PRESSURE AT MEAN SEA LEVEL IS 1"; MID$(N$(6),2,3); "."; MID$(N$(6),5,1);
270 PRINT "HPA"
280 END
600 REM ** WIND DIRECTION **
610 T$=MID$(N$(3),2,2): A=VAL(T$)
620 IF A=0 OR A>35 THEN 660
630 HI=(A*10)+4: LO=HI-9
640 PRINT LO; "-"; HI
650 RETURN
660 IF A=0 THEN PRINT "NO WIND"
670 IF A=36 THEN PRINT "355-4"
680 IF A=99 THEN PRINT "INDETERMINATE"
690 RETURN
```

```
STATION NUMBER: 00001
DATE 25 OF MONTH
TIME OF OBSERVATION WAS 1200 UTC
TOTAL CLOUD COVER IS 7 OKTAS
TRUE DIRECTION OF WIND IS WIND SPEED IS 13 KNOTS
AIR TEMPERATURE IS +06.9C
DEW POINT TEMPERATURE IS +04.9C
PRESSURE AT MEAN SEA LEVEL IS 1995.2HPA
```

Changes for the Amstrad PCW 8256 and 8512

```
20 PRINT CHR$(27)+"E"
80 IF N$(A)=" " THEN A=A-1: GOTO 70
110 PRINT CHR$(27)+"E"
```



# AN EASILY-BUILT 16-30MHz CON

Bryan Robertson G4POL

## Part 2

The component layout and double-sided track pattern of the printed circuit board are shown in Fig. 2.1. The board is made from double-sided, copper-clad, glass fibre material with the upper surface used as a ground plane.

All holes, other than those used for earthing the mixer M1 and crystal X1, should be cleared on the ground plane side to prevent short circuits when the components are mounted on the board. This can be done with a drill bit if you are not using a p.c.b. supplied by the *Short Wave Magazine PCB Service*.

### Ground Plane

When the board has been prepared the resistors should be soldered in place followed by the capacitors, note that C4, C5 and C9 have one lead bent to facilitate soldering to the ground plane. Care should be taken to do this and fine-nosed pliers should be used if possible to prevent damage to the component.

Next the coils should be placed on the board. L1, 2 and 3 should be wound so that the turns take up two thirds of the torroid, while L4 should be wound after the former has been glued into the mounting hole on the board.

The trimmer capacitors, followed by the mixer are fitted next and finally the transistors TR1 and TR2.

Three Veropins are used to provide easy connections to the board after it has

**Construction and alignment of the converter is straightforward and should present no difficulties, even for the beginner.**

been secured in the die-cast box. Before this is done the completed board should be thoroughly checked to ensure that there are no solder bridges shorting across adjacent tracks or pads.

Once the die-cast box has been fitted with the sockets and switches the board can be fitted and all connections made. The connections to the board should be made with miniature coaxial cable where applicable. The attenuator resistors, R1, 2 & 3, are mounted on the back of the attenuator switch S1.

### Power Supply

The minimum supply voltage is 9V d.c. and if an internal PP3 battery is used it should be held in place with double-sided tape to prevent damage or short circuits if the case is moved. The unit draws approximately 20mA and will perform slightly better if 12V is employed. The prototype used an external power supply and the appropriate terminals were fitted to the rear of the box.

### Alignment

Alignment is very straightforward. First adjust the core of L4 so that it is flush with the top of the coil former, then set the trimmer capacitors so that the plates are 60 per cent meshed. Finally check all connections, connect the converter to the receiver and an antenna to the converter using suitable coaxial cable and switch S1 OFF.

### Checking the Attenuator

If all is well the receiver should tune signals as normal. If not, there is a wiring fault, so check the connections again. If signals are heard switch in the attenuator (S1) to check that it works.

If you find a weak signal the attenuator should reduce it even further. This unit alone may make all the difference at night on 7MHz - the receiver manufacturers' nightmare test frequency.

### Switch On

So far so good. Now switch the converter on and tune to 14MHz on the R210. The crystal oscillator should be heard on s.s.b. Once the receiver is calibrated to 14MHz trim C2 to obtain a zero beat. Finally peak C10 for maximum output on the receiver. That's all!

If you are working during daylight

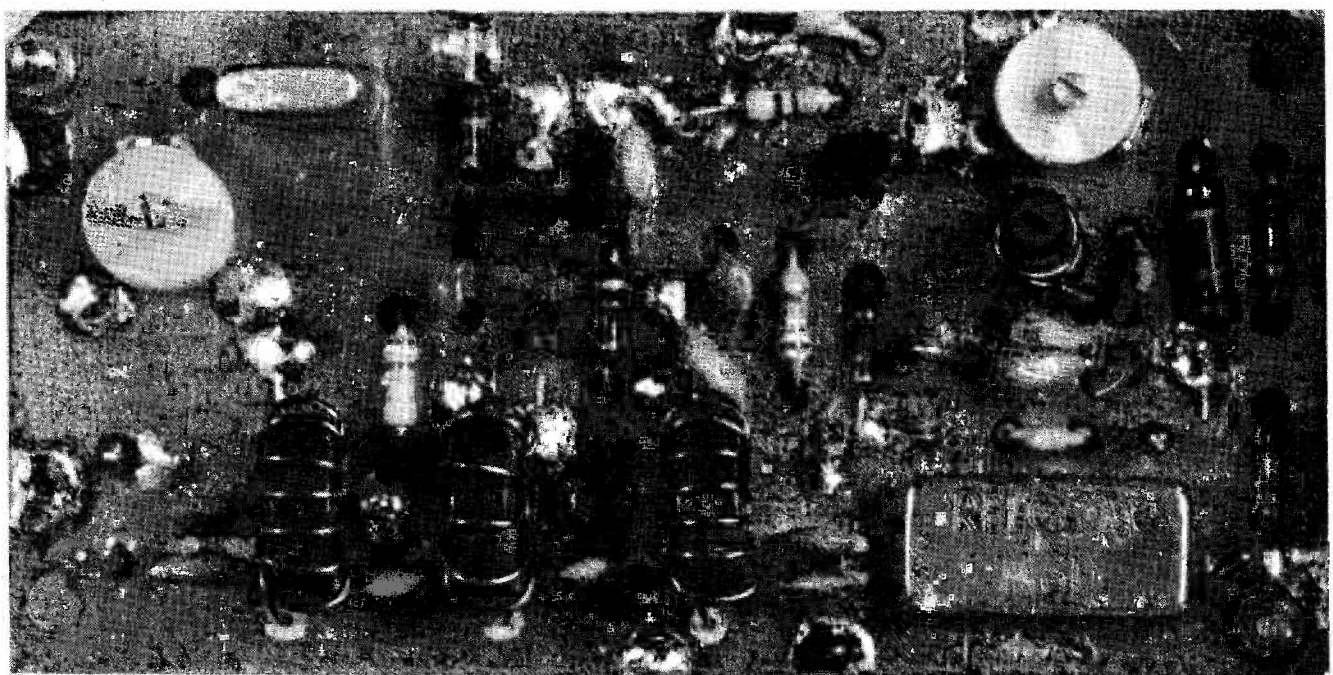

The completed prototype converter board showing the components soldered in place. Note how some components have one of their leads soldered directly to the copper earth plane which covers the component side of the printed circuit board.

# VERTER FOR THE R210 RECEIVER

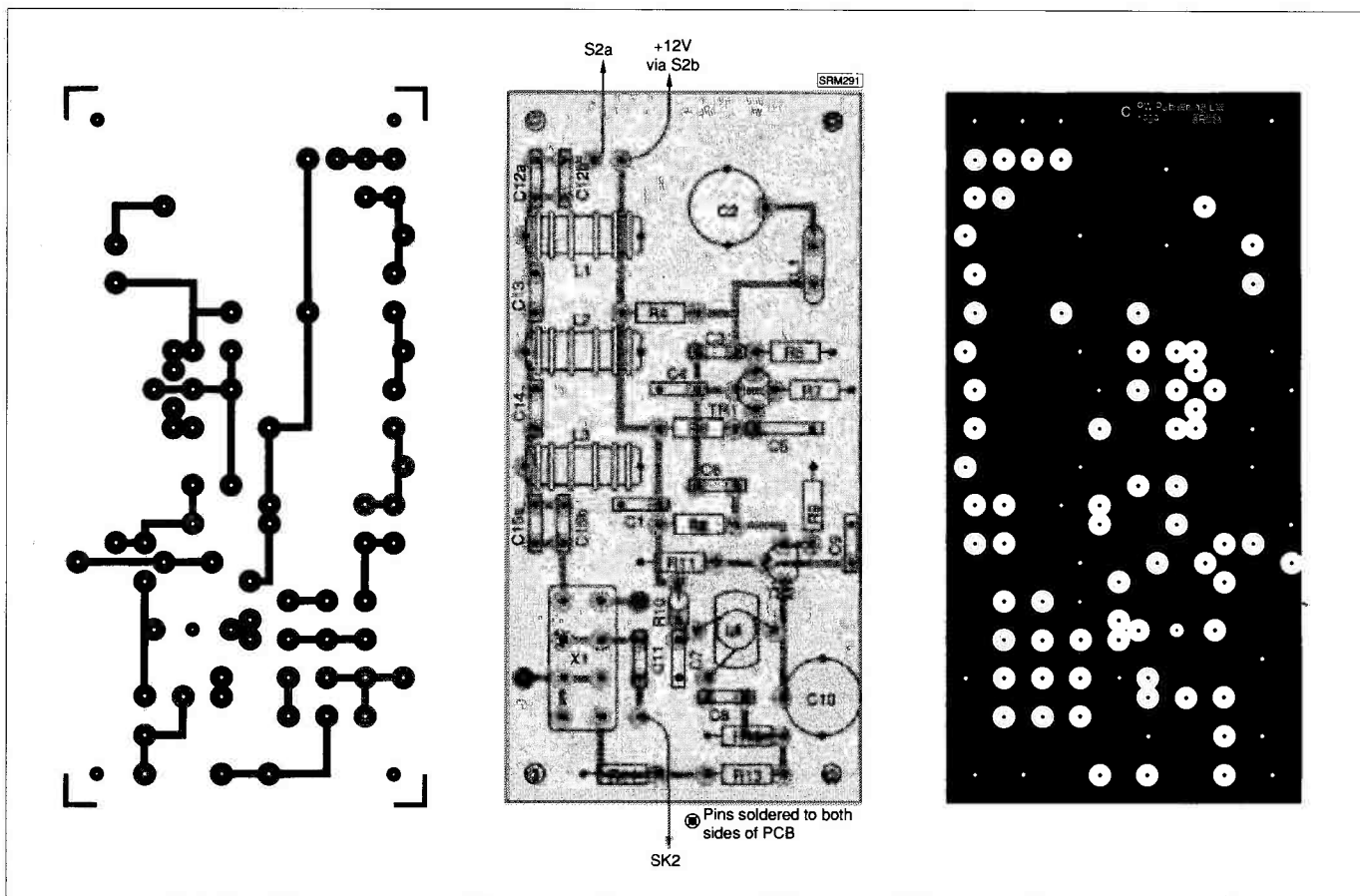

Fig. 2.1: Full-size copper track pattern, component overlay and ground plane for the 16 - 30MHz R210 Add-on Converter.

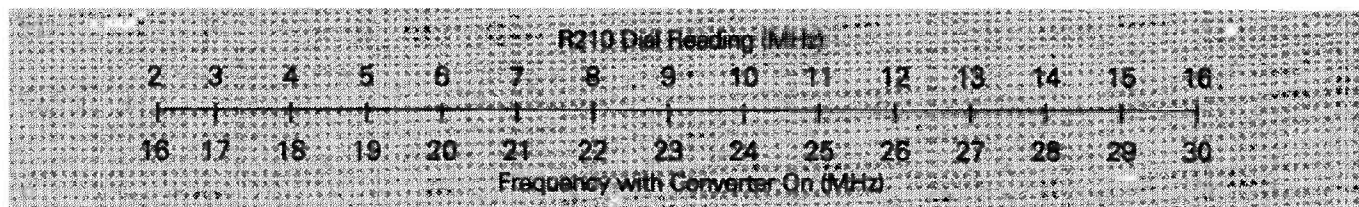

Fig. 2.2.

switch the converter off and tune to 11.790MHz when a signal in the 25m band should be heard.

Now switch the converter on and you should hear the signals of Radio RSA South Africa on 25.790MHz. Re-peak C10 for maximum audio output.

At night time the higher bands may have closed. If this is the case then you should try on the 13MHz band, or the 27MHz CB frequencies, which should be active at this time.

If a signal generator is to hand align the converter and peak C10 for maximum signal.

That completes the alignment. All that remains is to screw down the lid. Fig. 2.2 shows the frequency conversion relationship.

The converter was tried with an R210 receiver in the *Short Wave Magazine* Test Room with the results shown in Table 2.2. When connected to a longwire

Table 2.1: Coil Winding Details

Coil	Turns	Wire	Former	Notes
L1	7.5t	24s.w.g.	T50/2 torroid	
L2	8t	24s.w.g.	T50/2 torroid	
L3	7.5t	24s.w.g.	T50/2 torroid	
L4	24t	34s.w.g.	5.23mm dia.former.	Tap 7 turns from TR2 end.

antenna, signals on 28.5MHz were S9 during the afternoon.

Although this converter was especially designed to be used with the R210 ex-MOD receiver, it should work equally

well with any other receiver which is lacking in upper frequency coverage.

It should cost you about £2 per megahertz to build and at today's prices that is good value for money.

Table 2.2: Test Results

<b>Sensitivity</b>	15MHz 25MHz	2µV (a.m.) 2µV (a.m.)	R210 With converter
<b>Signal attenuation</b>	14MHz 10MHz	15dB 50dB	Through converter Through converter
<b>Conversion loss</b>		6dB (1 'S' point)	Through converter



# ENTERPRISE ERA RADIO APPLICATIONS LTD.

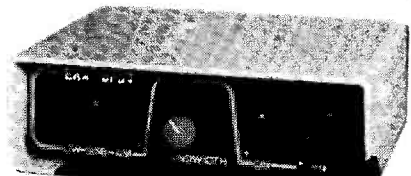

Price £99.50

SEE  
REVIEW  
PW SEPT 89

## BP34

The BP34 audio filter helps you hear weaker stations by eliminating adjacent channel & wide band noise interference. A must for SWLs/Contest groups/CW operators/Weather Fax users.

Easy to connect & use but despite its apparent simplicity, the BP34 has the highest performance specification of any filter you can buy. Exceptionally sharp cutoff, 80dB of stopband rejection & less than 0.3dB passband ripple makes the BP34 more versatile than a whole set of expensive crystal filters!

To order or for more information ring or write. We are open Saturdays for personal callers.

Also available from:

- |             |               |           |              |
|-------------|---------------|-----------|--------------|
| Electromart | - Swansea     | Third Eye | - Aberdeen   |
| Flightdeck  | - Stockport   | Wants     | - Plymouth   |
| Johnsons SW | - Worcester   | Ward Ecl  | - Birmingham |
| R.A.S.      | - Nottingham  | Waters &  | - Hornchurch |
| Star        | - Tyne & Wear | Stanton   | Essex        |

All Products unconditionally guaranteed for 2 years.

Tel: (0925) 573118. ERA LTD  
26 CLARENDON COURT  
WINWICK QUAY  
WARRINGTON WA2 8QP



All prices  
include VAT  
& P&P  
**£154.95**

## MKII MICROREADER

The Microreader is a small compact unit that allows anyone equipped with a suitable SW receiver, to read Morse & RTTY signals simply and without fuss. No computers, interfaces or program tapes are needed, just connect the Microreader to the ear or speaker socket & switch on. The decoded words appear on the built-in 16 character LCD display screen.

The Microreader contains all the filtering & noise blanking needed to allow reception even under bad conditions. A three colour bargraph tuning indicator makes precise tuning simple, while shift indicators take some of the guess work out of RTTY. Despite the fact the Microreader contains two fast processors (12MHz), it is extremely quiet generating virtually no RFI. The Micro-reader can also if you wish, transfer the decoded messages to any printer, computer or terminal unit equipped with an RS232 port.

In the tutor mode, the Microreader will send random groups of characters with variable speed & spacing, or plug in your own Morse key to check your sending. In both cases the characters are shown on the display.

The MKII Microreader comes complete with audio lead & demonstration tape. Full technical support & advice & a free upgrade service.

# JOHNSONS SHORTWAVE RADIO 'WE DO WHAT OTHERS DON'T'

## TMR 7602 HITECH TATUNG (SANGAN ATS803A MKII IMPROVED)

STOCKS NOW VERY  
LOW: GET IN NOW!

### SPECIFICATIONS & FEATURES

- ★ 150-29.999 continuous tuning with no gaps. Phase locked loop-double conversion Superheterodyne ★ Full Shortwave/AM/SSB 150-29999kHz No Gaps! + FM 87.5 - 108 Mono/Stereo ★ Five Tuning Functions: Direct Press Button Frequency Input Auto Scanning, Manual Scanning Memory Recall and Manual Tuning Knob ★ Built-in Clock and Alarm. Radio Turns on Automatically at preset time & Frequency. ★ Large digital frequency display.
- ★ Fourteen Memories - Nine Memory Channels For Your Favourite Station Frequencies. - Last Setting of Mode & Waveband Stored in 5 Memories. ★ Direct Press-Button Access To All 12 Shortwave Broadcast Bands. ★ Two Power Sources - Battery or AC Mains Adaptor. ★ General Coverage of all AM Bands In LW/MW/SW (Dedicated Broadcast Band Coverage on all Versions) Plus of Course The FM Band for Quality Sound Broadcasts in Headphone Stereo. ★ SLEEP Function Turns the Radio On or Off After an Adjustable Time of 10-90 Minutes. ★ Separate BASS & TREBLE Controls for Maximum Listening Pleasure.
- ★ External Antenna Jack for Better Reception. ★ Adjustable RF GAIN Control to Prevent Overloading When Listening Close to Other Strong Stations or if There is Interference.
- ★ New improved wide/narrow filter (6/2.7kHz) ★ BFO Control (Beat Frequency Oscillator) Enables Reception of SSB/USB/LSB (Single Side Band) and CW (Morse Code) Transmissions.
- ★ Illuminated Display to Facilitate Night-Time Use. ★ Designed for Both Portable and Desk Top Use. ★ Five dot LED Signal Strength Indicator.
- ★ Dimensions: - 29.2cm x 16.0cm (11.5in. x 6.3in. x 2.36in.)
- ★ Output: - 1200mW (10% THD). ★ Weight: - 1.7kg. (3.75lbs) Without Batteries.
- ★ Wide/Narrow Filter Switch.

**£109.99**

COMPLETE WITH  
MAINS POWER

FREE GIFTS ★  
SONY SHORTWAVE GUIDE  
STEREO HEADPHONES  
100 PAGE FREQUENCY BOOK

**£8** CHECK/TEST/POST & PACK

OPTIONAL CARRYING CASE £14.99 + £1.50 p&p

Also suits a Philips D2935, Grundig 400/500, Sony 2001D and similar sized radios.

## ITC-RC10

10 WAVEBAND  
GLOBAL RADIO  
MAINS AND BATTERY

**£44.95 + £5 carriage**

## NEW 1990's SONY ICF-7600 STEREO MULTIBANDER IN STOCK

A NEW GREAT PERFORMER  
AT A SILLY LOW PRICE

**GRUNDIG SATELLITS**  
25 years in production  
400 - 500 - 650  
International models

**GRUNDIG COSMPOLIT**  
£129.95

Multiband radio recorder  
**GRUNDIG YACHT BOY**  
All band world radio

Made in 'Brum' "I don't believe it!"  
S.W.L. A.T.U. (matches any radio  
to any aerial) Yes! the price is right  
£36.00 + £3.00 p&p.

Want to get the best out of your portable?  
S.W.L. DX Aerial complete  
£10.95 + £3.50 p&p  
Suits Matsu, Saisho, Philips, Sony,  
Panasonic, Realistic, etc., etc., etc.

**G5RV FULL SIZE**  
10 - 80 metres  
£16.50 + £3 carriage  
Start listening to the station, not the noise.

**S.A.E. ON ALL CORRESPONDENCE. SORRY BOYS, NO STAMP, NO REPLY!**  
**PRETTY GOOD CATALOGUE**  
£1.00 + 50p p&p  
LOTS AND LOTS OF GEN

**VEGA 215**  
**SELENA WORLDMASTER**  
Global receivers arriving shortly  
(Get your name on the list)

## LARRY MAGNE

(PASSPORT TO WORLD BAND RADIO)

STATES: OUR FIRM (ME & HER) GIVES FAST, GOOD, RELIABLE SERVICE

TESTIMONIAL HERE FOR ANYONE TO EXAMINE OR ADMIRE

**WHY NOT GIVE US A CALL OR A VISIT IS EVEN BETTER**

'LARA' THE DOG DOES NOT BITE - THE WIFE MIGHT THOUGH  
THANKS TO THE THOUSANDS WHO CAME TO OUR STAND AT HERFORD AIR SHOW  
AND MANY THANKS TO COLIN AND KEITH IN CHARGE OF CROWD CONTROL  
**REMEMBER WE'RE AT 43 FRIAR STREET, WORCESTER WR1 2NA**

VISA

WCSM

090525740

WYFR



# DXpedition to

# Ecuador

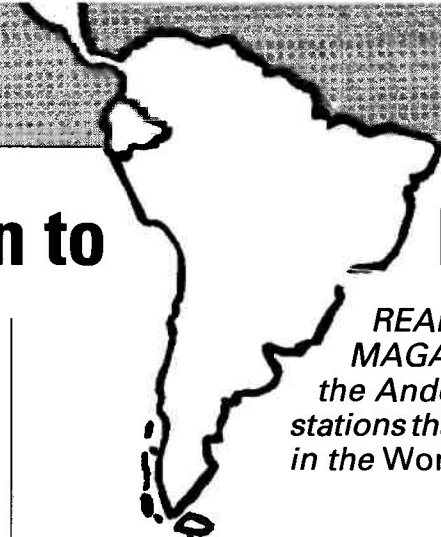

Short Wave Magazine and HCJB-UK are organising a two-week DXpedition to Ecuador. You will have the opportunity to visit HCJB's transmitters, studios and hydro-electric plant as well as some other radio stations in Ecuador. However, the two weeks holiday will not all be radio - you will have plenty of time for sight-seeing and visiting the contrasting sights of Ecuador, making this a holiday that you will not forget in a hurry.

**READER OFFER FROM SHORT WAVE MAGAZINE...Do you fancy a holiday in the Andes visiting and listening to radio stations that you have only ever come across in the World Radio and TV Handbook?**

## Itinerary

Those readers participating in the SWM/HCJB-UK Ecuador DXpedition will fly from London, Heathrow in May 1991 en route for Quito, capital city of Ecuador. The itinerary in Ecuador will include a tour of Quito, trips to the equator and the rain forests of the Amazon, visits to the Otavola Indian market and the San Antonio wood carvers. HCJB, the Voice of the Andes, has its headquarters in Quito, and we will be visiting the transmitter site, the studios as well as the hydro-electric plant across the Continental Divide. There will also be opportunities to visit other radio stations in Ecuador as well as taking sight-seeing tours and time for shopping.

## Ecuador

Ecuador is a land of contrast, with lush green jungle and treeless mountain slopes, placid lakes and raging streams, quiet villages and busy cities. It is the home of the Panama Hat and produces bananas, balsa wood, cocoa and oil which it exports world-wide. Quito is only a few minutes drive from the equator and a short distance from the Continental Divide, at an altitude of 2800m, and temperatures range from around 5°C at night to 23°C at midday.

insurance, meals and accomodation in Ecuador and tour-arranged transportation. This price is subject to change due to currency fluctuations or increases in air fares. A deposit of £50.00 per person is required with the booking. This is part of the total cost of the tour, but is non-returnable if cancellation is made after thirty days before the tour starts.

Legal: A valid passport is needed but there are no visa requirements.

Medical: No compulsory injections or vaccinations are required, but you are advised to consult your doctor for recommendations. Remember, Quito is 2800m (9500ft) above sea level.

Clothing: Spring or autumn clothing is the most appropriate together with good walking shoes.

## Tour Information

Cost will be about £1100 including Economy Class air fare London to Quito and return by regular scheduled flight,

## RESERVE YOUR PLACE NOW

To reserve your place, fill in the coupon and post it to **SWM Ecuador DXpedition, FREEPOST, Enefco House, The Quay, Poole, Dorset BH15 1PP** together with a cheque for £50 made payable to Short Wave Magazine. You will be invoiced for the balance thirty days before the departure date. **Places are limited so don't delay.**

Name .....

Address .....

Tel No. ....

Post Code .....

Please reserve.....places on the SWM DXpedition to Ecuador leaving London on 27 March 1991.  
I enclose £50 booking fee per place and agree to pay the balance when requested.

I enclose P.O./Cheque No.....Value £.....  
Please charge my credit card account. Expiry Date.....



Signature.....

**RING RADIOLINE EVERY WEEK FOR THE LATEST IN THE WORLD OF RADIO**

**0898 654 676**

**UPDATED EVERY SATURDAY**

**Calls charged at 38p per minute peak, 25p per minute off-peak.**



# STARTING OUT

Brian Oddy G3FEX

Almost all modern commercially made receivers are based on the superhetrodyne principle, although they are inherently more complex than other types. The basic operation of various types of superhet has already been outlined in this series (January, February, March '88). Many domestic receivers are of the single conversion type - see **Fig. 1**. In this arrangement the desired amplitude modulated (a.m.) signal ( $f_s$ ) is selected by a tuned circuit and applied to the input of a frequency changer or mixer stage, where it is heterodyned with the output from a local oscillator. The frequency of oscillation ( $f_o$ ) is usually higher than that of the incoming signal ( $f_s$ ). Sum and difference frequencies are produced ( $f_o+f_s$ ,  $f_o-f_s$ ), but the difference frequency ( $f_o-f_s$ ) is usually selected. This lower 'intermediate frequency' (i.f.) replica of the incoming signal is amplified by two sharply tuned stages and then demodulated - see page 32, July '88 *SWM*. The audio output from the demodulator is amplified before being applied to the power amplifier which drives the loudspeaker - see page 33, March '90 *SWM*. A small portion of the output from the last i.f. amplifier is rectified to produce an automatic gain control (a.g.c.) potential which is applied as a bias to the i.f. stages - see page 29, November '88 *SWM*.

## Tracking

A self-excited local oscillator is commonly used in the simpler types of superhet receiver, the frequency of oscillation ( $f_o$ ) being determined by an inductor and a variable capacitor. The tuning of the oscillator and that of the input to the mixer have to be kept in step when searching a band for a wanted signal, so that the same i.f. is always produced. The maintenance of this constant frequency difference is called tracking. Although the variable capacitors associated with each circuit can be mechanically coupled, or ganged, so that they move together when the front panel tuning control is adjusted, it is unlikely that the circuits will track correctly because the range of frequencies covered by the incoming signal circuit are not the same as those of the local

The performance of a superhet receiver is very dependent upon correct alignment of the variable-tuned circuits in the front-end. To obtain the best sensitivity and minimise spurious responses they must be kept in step over each tuning range.

oscillator. For example, the signal circuit of a medium wave receiver must tune from 550 to 1620kHz to cover the band, but to obtain a constant i.f. difference signal of typically 470kHz, the local oscillator will have to tune from 1020 to 2090kHz.

The difficulty of maintaining correct tracking becomes more acute when the ratio of i.f. to signal frequency ( $f_s$ ) is high, also when the signal frequency tuning range is large, i.e. the ratio of maximum to minimum signal frequency is high. For example, if a receiver with an i.f. of 470kHz is operated in the m.w. band the ratio of i.f. to  $f_s$  will be high, ranging from 0.29:1 to 0.85:1, (i.e.  $0.470/1.620$  and  $0.470/0.550$ ). The ratio of maximum to minimum signal frequency will also be high, namely  $1.620/0.550 = 2.94:1$ . Such high ratios imply that substantial measures will be required to minimise tracking errors. However, if the receiver is operated in the 49m band (nominally 5.950 to 6.200MHz), the ratio of i.f. to  $f_s$  will be low, ranging from 0.075 to 0.078 (i.e.  $0.470/6.200$  and  $0.470/5.950$ ) and the ratio of maximum to minimum signal frequency will also be low, namely 1.04:1 (i.e.  $6.200/5.950$ ), consequently it will be a relatively simple matter to ensure correct tracking.

Incorrect tracking results in a loss of signal strength, but the severity of the loss depends upon the selectivity of the tuned circuit ahead of the mixer. The effect is less obvious if the circuit has a broad response i.e. low selectivity, but a sharply resonant circuit is desirable to minimise cross modulation and reduce the amplitude of unwanted 'image'

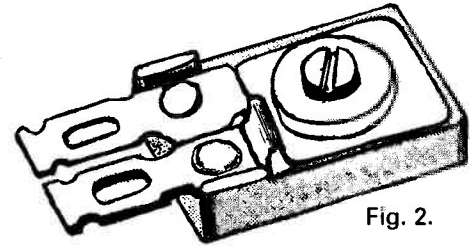

Fig. 2.

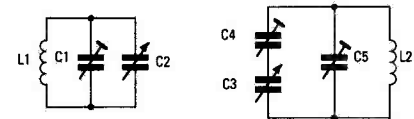

Fig. 3.

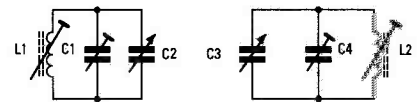

Fig. 4.

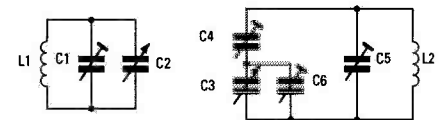

Fig. 5.

signals - see page 34, February '88 *SWM*. Some method of ensuring that the signal frequency and oscillator circuits will track correctly is therefore required.

A two-gang variable capacitor with identical sections is employed in many receivers to simultaneously tune the signal frequency and local oscillator circuits. The frequency of oscillation ( $f_o$ ) is always higher than that of the incoming signal ( $f_s$ ) by the amount necessary to produce the required i.f. ( $f_o-f_s$ ), consequently some form of tracking element has to be introduced to reduce the proportional coverage of the oscillator and thereby ensure that the frequency will change by the same amount in both circuits when the setting of the ganged variable capacitor is altered.

One method of achieving this is to reduce the effective range of the variable capacitor associated with the oscillator. The basic circuit required is shown in **Fig. 3**. The signal circuit at the input to the mixer is represented by an inductor ( $L_1$ ), which is tuned by one section of the ganged variable capacitor ( $C_2$ ). A small pre-set capacitor ( $C_1$ ), known as a trimmer, allows adjustments to be made to the minimum capacitance of  $C_2$ , thereby affecting the tuning of  $L_1$  at the high frequency end of the range. The oscillator tuned circuit is represented by an inductor ( $L_2$ ) and the second section of the ganged variable capacitor ( $C_3$ ), which is identical to  $C_2$ . The series connected pre-set capacitor ( $C_4$ ), known as padding capacitor, enables the

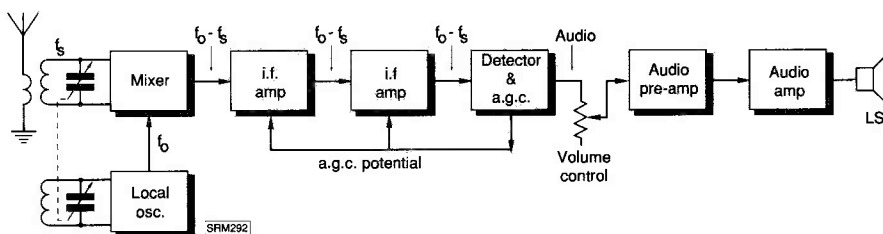

Fig. 1.

# Best Prices & Fast Delivery!

Most makes of receivers ex stock. Superb after sales service.

## Just Published!

SEVENTH EDITION

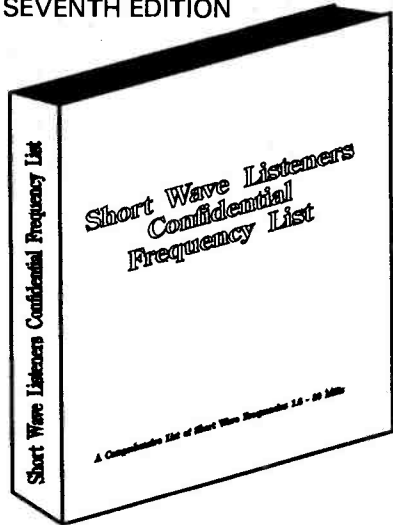

Order by Phone  
0702 206835

Short Wave  
Listener's  
Confidential  
Frequency List

**£8.95**  
Post &  
Packing  
£1

- Best times for UK reception
- Military & Civil Air channels
- Marine Channel numbers
- Military Ground & Sea listings
- Broadcast & Press listings
- AM SSB CW RTTY SITOR FAX
- Every entry reviewed or updated
- 200 Pages packed with information
- Numerical Frequency listings
- Block designations of primary users
- Station location and modes

## 18th Birthday Celebrations

Shortly we shall have achieved eighteen years in amateur radio. As a way of saying thank you to our old customers and hopefully winning some new ones, we intend making some unique offers over the next few months. Here are some examples. If you don't see what you need, then please phone!

**KENWOOD R2000**  
150kHz - 30MHz  
SSB-CW-AM-FM  
10 Memories VHF Option

**£535**



**KENWOOD R5000**  
100kHz - 30MHz  
SSB-CW-AM-FM-FSK  
10 Memories VHF Option

**£789**



**SONY ICF 2001D**  
150kHz - 30MHz + Airband  
SSB-CW-AM  
32 Memories Mains/Batt

**£275**



**ICOM R7000**  
25MHz - 2GHz!  
SSB-CW-AM-FM  
99 Memories Many Options

**£889**



## New! AR-1000 Hand Scanner

The AR-1000 is the latest version of the "Fairmate" but with a few extras.  
8-1300MHz AM/FM/WFM

You get the AC Mains supply, an extended frequency coverage down to 8MHz, and UK programmed bands. The receiver has been specially produced for the UK and European band plans and makes for easier operation. Of course you still get your 1000 memories and all the extras such as case, DC lead, aerial, etc. You also get the advantage of our after sales service!

**Our Price £245**

Add £3 Post & Insurance



## New! ICOM R1 "Micro" Scanner

150kHz-1300MHz! The radio Spectrum in your palm, includes 100 memories, 11 search steps, AM/FM, Wide FM, Clock Timer, S-Meter, Power Save, Rotary Channel Control, and much more. We now have the latest version in stock shipped in July.

**Our Price £389**

Add £3 Post & Insurance



## JUPITER 25 - 1300MHz Simply the "BEST"

The Most Logical  
The Most Sensitive  
The Most "Widely Used"

**MVT 5000 (New Price)**  
Now includes Ni-cads, case  
and 12V charge lead.

### General Features

- Switchable AM/FM.
- 25-550MHz & 800-1300MHz.
- Proper manual up/down electronic tuning.
- 100 memories in 5 banks of 20.
- Selective bank scanning.
- 10 programmable band segments.
- Priority channel.
- Any memory channel can be temporarily passed.
- Steps of 5, 10, 12.5, 25 or 30kHz.
- Auto frequency correction for step changes.
- Band Search or Memory Scan.
- Carrier or audio locking.
- Permanent/temporary hold.
- Delay.
- Slow/Fast speed (20 steps per second).
- Battery saver circuit.
- Large speaker for good audio.
- BNC Socket.
- Proper English manual for UK market.
- Not an American import
- Key lock.
- Telescopic antenna.

INCLUDES  
AC PSU.

MVT 6000BASE/MOBILE

**£345**

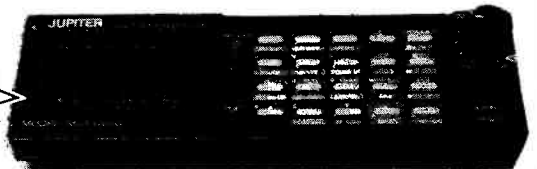

FREE DELIVERY ON ALL JUPITERS

**£275**

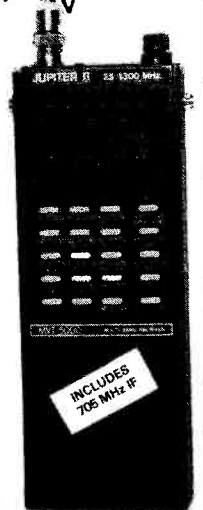

**WATERS  
& STANTON**

RETAIL & MAIL ORDER - 18-20, Main Road, Hockley, Essex SS5 4QS  
Tel (0702) 206835 204965

RETAIL ONLY - 12 North Street, Hornchurch, Essex RM11 1QX  
Tel (04024) 44765

Visa and Access by telephone 24hr Answerphone Open 6 full days



# SKYSCAN DX

## VHF – UHF BASE SCANNER ANTENNA

VHF 60-107 MHz	AIR 108-136 MHz	VHF-H 137-175 MHz	UHF 176-525 MHz	Cellular Phones
----------------------	-----------------------	-------------------------	-----------------------	--------------------

A good base station antenna can drastically improve the performance of your scanner.

The sky-scan base antenna has been developed especially for use with scanners.

**Sky-scan** can be mounted: Outside on a pole, in a loft, on a balcony, or even in a room.

Dimensions: Height: 43"; Diameter: 1".

Make sure you *get the correct* antenna for your scanner.

### UNIDEN BEARCAT 200 XLT SCANNERS SPECIAL

£229.95  
NO CHARGE for  
postage & packing or insurance  
VALUABLE FREE GIFT  
WITH THE SCANNER  
Please ring for details!

Just Arrived!

### SKY-SCAN MOBILE ANTENNA

Magmount antenna complete  
£19.95

### GUTTER MOUNT antenna complete

£19.95 plus £2.00 P&P  
Same coverage as base Antenna

SKY SCAN - DX

**NEW LOW  
PRICE  
£19.95  
+ £2.50  
P&P  
SKY-SCAN  
BASE  
ANTENNA**

**TRADE  
ENQUIRIES  
WELCOME  
Open MON - FRI  
9.00 - 5.30**



Name .....

Address .....

## S.R.P. TRADING

UNIT 20A, NASH WORKS, FORGE LANE, BELBROUGHTON,  
NEAR STOURBRIDGE, WORCESTERSHIRE.  
Tel: 0562 730672 Fax: 0562 731002

**SSE**

THE CHARACTER & SCANNER SPECIALISTS

**JIM PSU-101**

**HIGH QUALITY ACCESSORIES**

**FOR SCANNING MONITOR RECEIVERS**

The JIM PSU-101 is a high quality UK manufactured fully regulated 220-240V AC power supply with Radio Base holder combined! For use with: FAIRMATE HP-100E, AR-1000, YUPITERU MVT-5000, REALISTIC PRO-38, ICOM IC-R1, UNIDEN UBC50XL, BC55XLT, UBC70XLT, UBC200XLT, UBC205XLT, UBC100XLT. Special versions are available with 9V DC or 6V DC for PRO-34 or WIN 108 etc.

Payment: By postal order or cheque.  
Price includes postage.  
Further information send A4 SAE.

**Solid State Electronics (UK)**

6 The Orchard, Bassett Green Village  
Southampton SO2 3NA.

**Price: £26.50**

NEW  
PSU 101  
MAIL

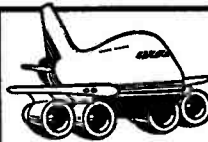

## FLIGHTDECK THE AIRBAND SHOP

192 Wilmslow Rd., Heald Green, Cheadle, Cheshire SK8 3BH  
Telephone: 061-499 9350 Fax: 061-499 9349

### JUST 26 OF THE MANY REASONS TO VISIT US:

AIRBAND MONITORS BOOKS CHARTS DISPLAY MODELS EUROPEAN SUPPLEMENT FREQUENCY LISTS GIFT IDEAS H.F. MONITORS IMC MODELS JP. FLEETS KENWOOD LOWES MAGAZINES N.O.A.A. CHARTS OPTICS POOLEYS QUALITY SERVICE REGISTERS SONY TOPO CHARTS UNIDEN SCANNERS VIDEOS WIN 108 X-STALS YEARS OF EXPERIENCE ZOOM SCOPES . . .

Opening Hours: Monday to Saturday 9.30 a.m. - 5.30 p.m.

### PLEASE NOTE OUR NEW ADDRESS

We are now located on the A34 (Wilmslow Road), 2 miles South from the M63 Junction 10, just 3 miles from Manchester International Airport

Send 50p for illustrated Catalogue from Dept. SWM/2

## AERIAL TECHNIQUES

NEW

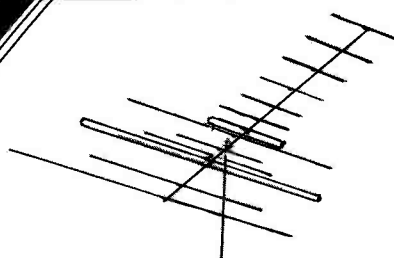

### AT/1/2/3/DX WIDEBAND HIGH GAIN TV-DXING AERIAL

This is the new wideband VHF aerial designed by ROGER BUNNEY and produced exclusively for Aerial Techniques, intended originally for the export market into the Arabian Gulf. We can offer the system in a non-compromise version for general wideband TV reception and the TV-DXer.

Constructed in hard drawn seamless alloy throughout with a rugged square sided 1" boom ensuring great strength and no 'boom sag', elements are 1/2" diameter in all bands for full wideband operation over its design bandwidth. The Gulf version model AT/1/3/G covers Band 1 (47-70MHz) at 4dB, Band 3 (175-230MHz) at 9.5dB gain maximum. The TV-DXing variation type AT/1/2/3/DX is shown above and features additional elements to increase coverage within the Band 2 (TV) spectrum 75-100MHz at 3.5dB gain. Coaxial downfeeder connection allows individual 'Low' and 'High' band VHF downleads, or with a phasing harness for a single wideband downlead. A substantial plated aerial clamp maintains aerial alignment under the most extreme weather conditions. This aerial sets a new standard for high quality ruggedised construction.

AT/1/3/G Wideband VHF TV Aerial (Export/Gulf version) ..... £49.95  
AT/1/2/3/DX Wideband VHF TV Aerial (TV-DXing complete coverage) ..... £57.50

Carriage & Insurance on either aerial is £5.95 ALL prices inclusive of VAT.

We supply aerial and receiving equipment for all types of domestic, TV-DXing, amateur and professional application. Our 29 page CATALOGUE at 75p is unrivalled in quantity, quality and sheer volume of content. Multi-standard TVs from 5" to 33" screen also PAL/SECAM Multi-standard Video recorders are our speciality. UK and Overseas orders undertaken both retail and wholesale, ring or write with your query.

**Special offer** — 4 1/2" screen VHF/UHF TV for DXing 12V battery or mains. £79.

Available now from stock SECAM to PAL Transcoders, also Telecom IC Signal Decoders for CANAL + and CANAL J (SAE for leaflet). RAI UNDO Decoder available soon.



ACCESS & VISA Mail & Telephone orders welcome.  
Also American Express (24hr. service)



11 KENT ROAD, PARKSTONE POOLE DORSET BH12 2EH  
Tel: 0202 738232

# STARTING OUT

effective capacitance of C3 to be reduced. The effect of C4 upon the tracking will be most noticeable at the low frequency end of the scale. To secure correct tracking at the high frequency end of the scale the effective minimum capacitance of C3 must be finely adjusted by means of trimmer (C5). Although C4 has a greater value of capacitance than C5, there is considerable interaction between them, so repeated adjustments have to be made at each end of the scale to minimise tracking errors.

A typical pre-set padding capacitor is shown in **Fig. 2**. The connections to the plates, which are interleaved with mica sheets, are brought out to solder tags. The capacitance is changed by adjusting the screw, which varies the pressure on the plates. When pre-set capacitors of this type are used in an oscillator circuit they are liable to introduce frequency drift. A more constant capacitance can be obtained with a fixed capacitor, so a compromise is adopted in some designs, whereby 50% of the capacitance required is provided by a fixed capacitor which is connected in parallel with the pre-set. The total value of padding capacitance depends in part upon the intermediate frequency and the tuning range(s) involved - a value of between 100 and 10000pF may well be required.

This type of tracking correction has been employed in broadcast band receivers for many years, but an alternative method is in common use nowadays - see **Fig. 4**. The essential difference in this arrangement is the use of dust-iron cores in the coils, which allow precise adjustments to be made to the inductance of L1, L2. Although the two sections of the ganged variable capacitor have identical characteristics, the need for a padding capacitor is eliminated. During alignment, the variable capacitor is first set to a pre-determined point at the high frequency end of the scale. A modulated test signal at that frequency is then injected into the mixer circuit. Firstly, the oscillator is set on frequency with C4. The mixer circuit is then peaked up with C1. The variable capacitor and signal generator are then set to a pre-determined point at the low frequency end of the scale. The dust-iron core in L2 is then varied to set the oscillator on frequency and the core in L1 is adjusted for maximum signal response. This procedure has to be repeated until the overall tracking with respect to the two frequencies of adjustment is optimised.

No matter how carefully these adjustments are made, it will not be possible to make the circuits track exactly over the entire range. Nevertheless, the difference between  $f_0$  and  $f_s$  will be equal to the i.f. at the two alignment points in each range and the error involved

Fig. 6.

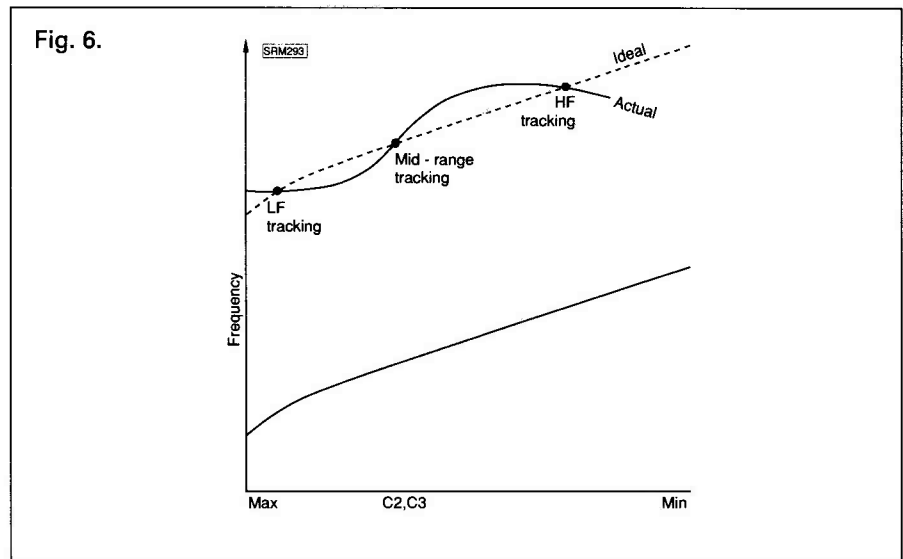

at any other point can be neglected in a receiver designed for broadcast band reception. However, some of the more advanced receivers employ a three-point tracking system to minimise these errors - see **Fig. 5**. Apart from an additional trimmer (C6), this circuit is similar to **Fig. 3**. Depending upon the values chosen for the components, corrections to the tracking at the high frequency end of the range can be made with C5, at the mid-range with C6 and at the low frequency end with C4. After repeated adjustments the tuning characteristic should be of the form depicted in **Fig. 6**.

Many of the older communication receiver designs employed two tuned r.f. stages ahead of the mixer, consequently a four-gang variable capacitor was required to tune the three signal circuits and the oscillator simultaneously. Tracking elements were usually included in all of the tuned circuits associated with each range. One of the finest examples of this form of construction, which is both complex and expensive, is the famous RCA AR88. Despite temperature compensation, rigid construction and extensive screening, the stability of the local oscillator in many receivers proved to be inadequate for the reception of single sideband signals.

The development of the frequency synthesiser led to a new era in communication receiver design, whereby gang tuning was employed for the r.f. and mixer stages, but a separate drift cancelling frequency synthesiser replaced the conventional self-excited local oscillator - see page 34, April '88 SWM. The Yaesu FRG-7000 is a typical receiver of this type. The main drawback to this approach is the necessity to peak up the gang tuning of the r.f. and mixer stages with a front panel control marked 'Preselector', as the injection frequency from the synthesiser is varied by adjusting the main tuning control.

Subsequent developments have resulted in new designs which eliminate the need for ganged tuning altogether! Instead of using conventional tuned circuits, a bank of band-pass filters is employed at the input to the r.f. and mixer stages. Each filter is accurately set up during manufacture so that only a narrow band of signals are permitted to enter these stages. A wavechange switch is not required, because the appropriate filters are automatically switched into circuit by diodes as the injection frequency from a voltage controlled oscillator (v.c.o.) in the synthesiser is varied - see page 32, May '88 SWM. In most receivers of this type the synthesiser can be controlled by a digital encoder which is manually operated from the front panel, or by digital information stored in a memory bank. In addition, 'up-down' switches are usually provided, so that the frequency of the synthesiser can be quickly changed in steps of 1MHz.

Although the use of band-pass filters greatly reduces the problem of tracking and alignment in a complex communication receiver, they tend to impair the ability of the front end to reject strong unwanted signals.

Abbreviations	
a.m.	amplitude modulation
i.f.	intermediate frequency
kHz	kilohertz
m	metre
MHz	megahertz
pF	picofarad
r.f.	radio frequency
v.c.o.	voltage controlled oscillator



# SEEN & HEARD

## AMATEUR BANDS ROUND-UP

Paul Essery GW3KFE  
PO Box 4, Newtown, Powys SY16 1ZZ

Here we are again, and at least able to report that we have been able to listen round again after the mishap mentioned last time. However, conditions have been typically summer, with the problem made worse by the wild swings in the solar flux as an active group of sunspots rotate round the back of the sun leaving a comparatively bare face visible.

### Thoughts

Many of your letters talk about antennas and antenna problems. There are five parts to consider: first to get up the best antenna one can, secondly to make the best improvement one can to one's earth system, in particular if using a wide-band antenna; thirdly to make sure the maximum signal is extracted from the antenna or feeder and passed on to the receiver; fourthly to try and isolate the receiver from man-made noises, and lastly to build an attenuator to connect between antenna tuner and receiver.

Taking the last one first, most of the other electrical goods in the house generate noise. This noise may be mains-borne or radiated. The preferred technique in almost every case is to suppress at source. A filter close up against each offender is the ticket to vote on. Against noise coming in up the mains, the only answer is to use a mains filter right close to the receiver; but you can soon determine the need for this by simply letting the receiver run without the antenna. If the QRM all goes away, you don't need a filter on the receiver. If you can be SURE where the QRM is originating from, one can lodge a gripe with the neighbour concerned; but gang warily on this as you can make a mistake! Example; I had severe QRM and set to D/F it. This led me first, seemingly, to a next door neighbour but as we got closer in, we came first to the corner of my garage where no electrical equipment was(!), and finally to a central-heating pump in my kitchen just on t'other side of the wall from the garage! Its suppression capacitor had come unscrewed and was jumping about in its fixing hole whenever the pump ran! BUT, the next door neighbour's pump was just behind the opposite wall - I could have complained to him about my own problems! Noise pick-up on the antenna can be reduced by reorientation, change of polarisation or similar modifications.

The 'best antenna' requirement is just that: the best you can manage within your circumstances. I can run to a beam and I have the rig in the living-room; but most visiting XYLS take one look and state firmly that their OM won't be allowed to copy! They hardly ever even notice my i.f. band wire, let alone that it is a 44m in an 8m garden. Mind, they do admire the roses that conceal parts of it. If the very best you can do is the whip on the receiver, so be it; but DO examine your thoughts before you give in! When stringing out a wire, it is well to remember that the most useful parts

of the antenna are those which occur at a quarter-wave, 3/4, 5/4 wavelengths back from the remote end on the frequency of interest.

Thus, if you are interested in say, Eighty, then you want to so arrange things that some 66' back from the remote end is a section of wire that is in the clear and as high as may be. This will give you an odd length overall, but the a.t.u. takes care of that question. If you switch to 28MHz, surely at least one of the current points will fall in the preferred bit of the wire. For multi-band use of course, this tends to mean your antenna wire 'favourites' one band. As for the earthing system, we have hammered that point enough of recent months, but we will just repeat that the more earthing you have out the better.

### Tuning the Antenna

This means buying - dirty word! - an a.t.u., or building one (or using a system which you can warrant as offering a low v.s.w.r. on all bands - if you can think of one). A home-built a.t.u. needn't look so pretty as the commercial item, and can be modified as an when you change antennas. In essence it is no more than a tuned circuit, with a secondary to feed the receiver, and a means of tapping the antenna on to the coil. I have a design on the go at the moment, and will present it once I have it finalised. It cost me nowt, which is how I like it, and all I did was scrounge a few of the round boxes in which chemists receive their supplies of pills and things, and save them from the bin. Incidentally one of them made a very acceptable case for a spare lens for the camera!

To use an attenuator seems daft. However, if you have a variable one in the line twixt a.t.u. and receiver, and you operate on the 160/80/40 metre bands, you'll have it in use nearly all the time. If you have the steps of attenuation so arranged that you can go in 1dB steps to 20dB, and then in 10dB steps, you will be able to experiment a little; the ideal is to use the minimum amount of attenuation that knocks away the noise and receives the signals; the big ones you hear over the noise won't mind the attenuator being in circuit and the weaker ones are inaudible until you use it!

### Safety

Finally, link each unit chassis to the earth terminal; electrically and in an emergency this is preferable to having a piece of wire joining all receivers and then wandering on to the earth terminal. Check the mains earth has continuity through from the earth pin of the plug which takes power to the station through to each chassis; get an electrician to check that the mains earth itself is all-present-and-correct-sir; and fit an earth-leakage breaker (e.l.c.b. or r.c.c.b.). It plugs into the wall socket and one plugs the mains lead into its socket. Then if an earth leakage problem occurs such as you getting yourself between live and

earth, the breaker will trip before you do yourself a mischief. I use the B & R Powerbreaker 2, obtainable from the local Woolworth.

### Letters

**Colin McGowan** is 14 and lives in Larbert; he has an R210 fed from a ten-metre wire some 6 metres and has been listening for around six months - and already Colin has rumbled that conditions tend to change in a seasonal kind of fashion. Some 170 countries are already in the log, and we guess, though he does not say so, that Colin favours the 14MHz area and s.s.b.

### Bad Manners!

**Leslie Griffiths** of Sheffield notes the somewhat moronic antics of, particularly, the character who deliberately QRMs the DX net on 14.175MHz with long test counts, recorded laughter and bursts of carrier. All one can say about that is that unless and until all the administrations in the world are prepared to stamp down HARD on the malefactors we won't get rid of them. At least in this country a start has been made in 'jumping on' a few of the repeater-jamming oafs - but they should never have been granted a licence in the first place.

Turning to a nicer topic, Leslie's Saisho SW5000 fed with either about 12m of wire or the telescopic built-in whip; as he says, a site at 425 metres asl does help! on 28MHz there was G4THO in contact with HB9LBM; on 24MHz Zilch, but on 21MHz there were YC7DF, YC7BDF, EA8BMM, YC2BLB, HZ1AB, J5NM, T77J, and Europeans; 18MHz produced YB0WR, 5B30SA, VE1YX, K2NR, VK3AHJ, VK2QL, KA1PE, and EU. Coming down to 14MHz we find RZ8/U4AFDS, K8EEH, J28AG, TA3G, XX9KA, JA6SS, 8S01TU, VK9DQ, PV8RF, KR8C/AM, 7Q7LA, JA8NFV, TA5KA, 4X/P/LY2PX, 9K2KS, LZ3TU/AM (said to be near Bombay), JT1BG, A41JR, J37KT, YV2CAY, 4J6X, KP4GY, G3ZKZ/P/W3, YV5AIP, TL8WD, PS7JS, KP4P, US1A, YU2RK, 5Z4BH, 5Z4FO, 6W1QC, VK9LL, and VK6RU. 10MHz is dismissed as 'chatterbox band for Fsl' while on Forty we find 7X4AN, ZP9/DL3RO, PY6AT, KP4IF, PZ5JR, RV3E/PJT1BY.

Dennis Sheppard of Earl Shilton comes next and he is specialising on 28, 24 and 3.5MHz this time; all SSB. Antenna is an inverted-V with the apex at 10m, and running E-W. Ten came across with JH0BBE, BY5TS, A22AA, HZ1AB, KB4LGG, W8GIO, 3B8CA, 8P6RE, HL9HH, Y11BGD, VK3MCO, A43KM/0, C53GB, V51BG, 7X4AN, 9K2EC, 9Y4DR, CP6XE, HV2CO, PR2A, V51P, ZD7VC, 7Q7JM, FT5XH, OY9JD, VU2NTA, YC30SE, 3W6PY, AH6HQ/TJ, TA5KA, TR8JLD, 9L1US, 9M2CW, TU2UI, TJ1RP,

ZD8PJ, 7Q7LA, 7P8DX, AP2UR, HS1BV, YC7UF, VP8CDK, Z27JV, 7O1AA, T7E, VQ9RB, TZ6FC, T5YD, XU8GX, 4S7EP, and VK9EW. Turning to 24MHz, Dennis noted A92BE, HK5LEX, HZ1AB, KA1XN, W20HZ, YB0USJ, TU2QQ, YE0AX, VE1YX, and TZ6VV. Finally Eighty, upon which PP7HS, PY0FF, and 5T5CK were all booked in.

Bob Alexander in Hurlford, Ayrshire is addicted to c.w. listening, and found the mode quite profitable, with new countries booked in by way of KP2BL in St Croix, VP5P in Turks & Caicos, KP4GC for Puerto Rico, FY5FO in French Guinea, 4S7WP giving Sri Lanka, Chile by way of CE3WD, and OX3TW for Greenland. Otherwise it was all continents but only a handful of Europeans.

John Heys looked at Forty to find ZB2B, and on Twenty managed UA1ZO, 3B9FR, TK/PA3DQW, and UA0/GB4ICE, EX1A - where was this, John wonders? - VK3EGN, U11D/U18IAY, VU2GR. On 21 MHz, VP5P, UA9LAC, JAS, YC2NFD, 4Z4UW, ER4L, KB6DDV/DU3, ZD8GT, and 5N0SKO. went down. Finally 28MHz, where UH8ABD, 4Z8C, 5B4YC, ZS200WOL, BY8AC, A41KM, 6W2EX, VP8CDR, G4WYG/ST2, C53GB, FT5XH, VQ9IF, 9J2FR, HZ1AB, S79FT, and VKs. All John's loggings were also c.w.

**E. H. Trowell** (Minster, Sheppey), said he didn't have so much time for listening as for chain-sawing! None the less, Ted did get on 10MHz to hook 4U5ITU and U0AG; on 14MHz he found G4WYG/ST2, VK5ALG, N6EA, K2VUI/VP9, VK6RU, VK3MJ, VK2PP, VK2QL, PZ1DY, RA9URC, JA7AS, ZC4RF, 9H1BB, VK5GZ, PY2GCW/PS8, TA5KA, and VK5AL. FY5FO and TA5KA were noted on 21MHz and VP2EXK was the only 28MHz entry in the book.

Now to **Charles Wells** (Mansfield) who notes with some regret that after two and a half years his XYL would no longer accept the proposition that the plaster needed time to dry out - he'll have us in tears at this rate! So, it's paint-pots and paper hanging tools to the fore for a while. Seriously, Charles is into the Oblast-chasing activity with over 100 confirmed and 135 logged. For those who don't already know, the Oblast is the Soviet version of our county; so once we started the county-chasing game in this country back in the 'fifties, first the Americans and now the Russians have brought out their own versions. Perhaps the biggest difficulty is that the Russians don't have mobile operation in the way the US do, so there's no chance of getting someone to make a quick trip to a rare one for you! On the other hand, of late, the gang over there have been putting up almost full-scale DXpeditions to the rare ones.

**Eric Master** of Welling is also GOKRT, and he is finding out that

For the latest DXpedition news you can always ring Wireless Life (compiled by Practical Wireless) on 0995 854333  
Calls charged at 35p peak, 25p off-peak



Now available

the **NEW**  
1990 catalogue  
from NEVADA



...in touch with  
the World!

Packed  
full of  
products  
and  
information  
on all the  
latest  
equipment...

still only  
**£2.00**

Send **Now** for your  
copy (Includes a £2 Voucher)  
Or Call using your Credit Card  
on our **HOTLINE (0705) 662145**

The UK'S Leading Distributor with Approved Dealers throughout the UK  
189 LONDON ROAD NORTH END PORTSMOUTH PO2 9AE

**NEVADA**  
COMMUNICATIONS



# SEEN & HEARD

with a simple QRP rig it is a bit easier to hear 'em than to work 'em. However, an a.t.u. and a quarter-wave counterpoise under the end-fed wire is helping things along. The 1.5 wattsworth and direct conversion receiver have successfully crossed the country from Kent into Wales on Eighty, and over the water to a couple of ONs, as well as an assortment of G stations.

Now to **D. L. McLean** of Yeovil, who finds his DX always on s.s.b. Don noted the way the solar flares would 'see off' the conditions on 14MHz, and as compared with previous years a shortage of the Pacific stations. He managed A43KM/0 (Kuria Maria), HL9HH, HL9KL, HS1BV, S79FT, TJ1SR, XV100HCM, V85GA, VKs,

VU2SMN, ZF2ME/ZF8, ZL2VS, ZS9S, 1A0KM, 3B8FU, 3D2AM (Conway Reef), and 9K2KS. On Fifteen, Don notes TA, Y, L, but not a lot from N. America or Africa. Nonetheless A22AA, A22MH, A43KM/0, CM5CB, C07IC, CP5HI, HL1KIB, HL1KII, HL9HH, HR1LW, HZ1AB, JA6IEF/6 (Koshiki Is), JT1BG, JT1BJ, LS9F, N2DRM/M, P29KRB, RA0AD/JT, RL5D/UW9YY, RL0M/RA9SB, S79FT, S92LB, SV7BAY, SV9ANK, TR8AHO, TU2QQ, TZ6CX, UA0FF, UF6FKW, UW0LAP, VKs, V47KTG, VP8BXX (S. Orkney), VR200PI/JR, VR6JR, W51JU, YC1YMN, YC0FEO, YJ8MB, Z21HD, ZV7AZ, 3X1SG, 4G3CI, 4U51TU, ZJ1AGW, 8J90XP, 9K2KS, 9L1US, and 9N1MM, while on 28 MHz there

were BY8AC, CP6RP, EM6AAK, FT5XH, G0JFX/MM, HL0B, Jas assorted and by the bucketful, S79MT, TU2PA, TU2QQ, V51SW, VKs, VP8CDR (Falklands), RL1M/RA9SFT, RL3M/UA9SAB, RZ8T/UA4FDS, ZD9BV, ZP5XHM/ZP8, ZS4AE, ZS60PTA, 3B9FR, 3W6PY, 3W9CZ, 5H1HK, 5Z4FM and 9L1US.

**M. Drew** (Wrexham) next; he has been alas very busy at work, which rather put a crimp in things of more importance. Nonetheless, on Eighty some SSTV was logged, plus 1A0KM, EA11F, and EA7CWA. EI2WW GB2SDD, EI7M and GB00BD were booked in on 7MHz plus a host of locals in the Wrexham Members HF Contest. On 14MHz there were SV5TS,

KA4NRZ, LY2BRP, CT1AF, 9H1GO and UA3/G3JYW.

## QSL Address

Just after last month's lot had gone down to the post, we received a letter from Steve Hodgson ZD8LI, who asks that all concerned could please take note of his new address: Steve Hodgson ZD8LI, PO Box 2, Ascension Island, S. Atlantic.

## Deadlines

The address is at the top of the piece, and the deadlines for letters are August 10 and September 10.

## DECODE

Mike Richards G4WNC  
200 Christchurch Road, Ringwood, Hants BH24 3AS

I have received several letters from readers commenting on my *Decoding The Dataseries*. It seems that this has been a very popular series which is good to know. Although I have only covered very simple systems, finishing with the basic ARQ modes, this is not the end of the story. I am currently preparing the details of a follow-up series that will cover some of the more complicated transmission modes. All I have to do next is convince the Editor to publish!

**Eric Sillick** of Ontario is a regular contributor and has recently changed his computer system to an Apple Mac SE. He didn't mention in his letter whether he is using the Mac for decoding or just for his general computing needs. One of the main uses for the computer is the handling of his very comprehensive log. Eric has sent me a copy of this which contains some 2000 stations. I wonder, does anyone else out there use a Mac computer for utility work? I know the editorial offices use them extensively for the production of the magazine, as the Mac system is the most popular Desk Top Publishing system.

I recently asked if any listeners were using the Datong FL2 Multimode Audio Filter and have received a response from **Ted Rickett** of Hampstead. He has been using an updated version with auto notch successfully for several years. The receiver is a Yaesu FRG-7700 and the decoder is a Pocomm AFR-1000. Ted reports particularly good results on c.w. and RTTY when using this filter. Ted admits that it took him quite a while to get used to the controls but once mastered the benefits are considerable.

Having recently visited a number of rallies, working on the *PW/SWM* stand I have met quite a few readers - something I always enjoy. At the Elvaston Castle Rally in I met John Daniels who contacted me seeking advice on what type of decoding system would best suit his interest. I think I managed to point him in the right direction. However, John did raise a point that has been mentioned by several readers. This concerned the split ferrite beads that I mentioned were available from TMP Electronics in the January 90 issue. The problem

was that I omitted the address of this company from the column. So just to put the record straight, here is the address: **TMP Electronic Supplies, Unit 27, Pinfold Workshops, Pinfold Lane, Buckley, Clwyd, N. Wales CH7 3PL**, Tel: (0244) 549563. As the prices and product range may have changed since my original mention, it may be worth giving them a ring for the latest details.

**Thomas Barnett** of Slough and **Mr S. Parry** from Runcorn both have similar problems in that they have recently bought ERA Microreaders and are having a little difficulty receiving RTTY signals. This is a common problem encountered by newcomers to utility listening and is not a fault with the Microreader - it happens with many other systems. The problem really comes down to lack of experience and is one of the things that makes this hobby so fascinating.

There are many signals on the h.f. bands which sound very much like RTTY signals but are not! It is this phenomenon that confuses both newcomers and experienced listeners alike. The only easy solution is to use a simple frequency list to guide you to 'real' RTTY signals. To provide some immediate help I have included some stations in the frequency list at the end of this column.

**Ray Howgego** of Caterham uses a not so common data decoder - the Comax CD670. This is a self contained decoder which displays the decoded text on an internal 80 character liquid crystal display.

For those who prefer a larger display, it has an output that will directly drive a standard u.h.f. television which is very convenient. Other than being self contained, another advantage that this unit has over many others is that it is tunable. This may at first seem an odd point to raise but anyone who uses a receiver with tuning steps of 100Hz or greater will soon recognise the advantage. If you are attempting to receive data signals using a 170Hz shift, all amateur RTTY and most commercial ARQ mode A, with a receiver with coarse tuning steps you will find that it is impossible to tune correctly. If you had a tunable decoder such as the CD-670 you tune as close as practical

and then make the final adjustments on the decoder itself.

The modes covered by the CD-670 are: RTTY, TOR, CW and ASCII.

One fairly obvious question from Ray concerns ASCII transmission and where to find them. I'm afraid I haven't got any great news on this front as ASCII is rarely used commercially these days. The only regular ASCII transmissions I'm aware of are the amateur radio news broadcasts from the ARRL. However if anyone knows of any other, particularly commercial ASCII transmissions, please drop me a line.

## QSLs

This is a very rewarding area of our hobby which opens up a whole new world. There are several readers who regularly send me details of their QSL successes and I am always amazed by the wide range of replies they receive and the stations that reply. A classic example of this a QSL with the US Air Force in Hawaii which was sent in by **Dick Moon** I have reproduced the core of the text here so you can get a feel for the tone of the letter:

"It is always interesting to receive these reports from interested radio operators like yourself, from the details you have provided me yes I can confirm the reception..... Feel free at any time you receive our radio signal to write to us for confirmation. We will answer most any questions you have but remember some we can't..."

In addition to the American services, Russian stations are usually willing to QSL, with the TASS News Agency being a common example.

Of the recent examples sent in by Dick Moon probably the most unusual was one from a Pan-Am aircraft. The aircraft was attempting to contact Rangoon whilst flying 200nm north of Antigua. It seems that this station is notoriously difficult to raise and the pilot commented "sometimes it feels as if we're talking to ourselves!".

If you're new to QSLing you are probably unsure just what to put in your report and where to send it! So, to help you on your way, here is an example of the type of QSL letter used successfully by Dick Moon:

Dear Sir,

As a regular s.w. monitor I was pleased to receive your transmission, the details of which are set out below.

Should the details agree with your records I would be very glad to receive confirmation, either by letter or QSL card. I enclose 1IRC to assist with return postage.

My equipment consists of (your equipment). My station is located in (town) which is (distance and direction from large City).

Transmission Report  
kHz UTC Date SINPO Remarks

Best wishes to you and your staff.

There are of course many other ways to put together a QSL, but the friendly approach is the one most likely to succeed.

One of the added advantages of QSLing is that you often find that stations will include a range of interesting information about the station.

I'm always interested in hearing of interesting QSLs so please drop me a line if you have any examples.

## FAX Guide

I've just received the latest, tenth edition, of the *Klingenfuss Guide to Facsimile Stations*. This publication has been running for several years now and serves as an extremely useful guide for the FAX enthusiast. The book has grown in size considerably during this period and is now nearly 400 pages.

In addition to the expected frequency list of FAX stations there are many other useful items. One of the most useful sections is the list of FAX station schedules. This shows the transmission schedules for all the major stations throughout the world. I find this to be the most used section of the book as I just look at the range of charts being sent at a particular time of day and tune in to the most interesting. The only point I would make is that it is impossible for the schedules to be 100% accurate as many stations change their schedules quite frequently. Nevertheless the

# ASK ELECTRONICS LTD.

248-250 TOTTENHAM COURT ROAD  
LONDON W1P 9AD

TEL: 071-637 0590/071-637 0353 TELEX: 27768  
FAX: 071-637 2690



**£119.95**

**D 2935**  
● All-electrical Digital World Receiver ● LW/MW/FM/13×SW ● Continuous tuning over total AM band ● Direct keyboard tuning ● 9 station memory ● Variable pitch BFO for CW/SSB reception ● Touch-panel switching ● LCD frequency display ● Mains/battery supply

**ICF 2001D**

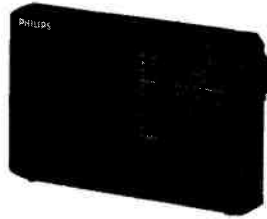

**D 1875**  
● Compact 12-Band Portable Radio ● LW/MW/FM/9 short wave ● Large tuning control ● Tuning LED indicator ● Telescopic and ferroceptor aerials ● DC supply connection ● Earphone connection ● Wrist strap ● Attractive pouch

**£49.95**

## PHILIPS



ALSO IN STOCK  
PHILIPS D1835  
SAME AS D1875  
ONLY

**£39.95**

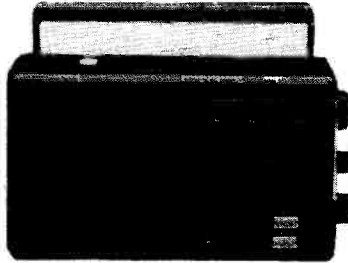

**D 2345**  
● Portable Radio ● LW/MW/FM/2×SW ● Fine Tuning control ● Mains/battery supply

**£24.95**

WE ALSO STOCK A WIDE RANGE OF MULTI  
STANDARD TV'S AND VIDEOS



## SONY

**FINEST ALL-ROUND PRO-RECEIVER IN THE BUSINESS**

● FM/LW/MW/AIR multi-band reception ● 32 station preset memory ● Synchronous Detector Circuit ● PLL quartz-locked synthesizer circuit ● Digital/analog tuning ● 2-way scan modes (auto stop, 1.5 sec. hold) ● 2-position AM selectivity ● AM RF-gain control ● 3-way scan tuning (memory, broadcast, define) ● 3-position tone control ● Direct meter band access ● 4-event programmable timer ● AM attenuator ● SSB reception ● External antenna for AM, FM and AIR band ● 288×159×52mm (w/h/d) ● 1.7kg.  
**2001D SYSTEM** — ICF-2001D with active antenna AN-1 in one complete package.

**\* £319.95\***



**ICF 7600DS**

● PLL synthesized multiband digital radio ● 4-way tuning ● Direct frequency LCD read out ● 10 memory presets ● 10 key auto and manual scan ● Full continuous waveband coverage 153-29995kHz; FM 76-108MHz ● Single side band and fine tune controls ● Tone control ● External aerial socket ● Record out socket ● 12/24 hour LCD clock ● 65-minute sleep timer ● Supplied with waveband manual, case and wrist strap

**\* £139.95\***

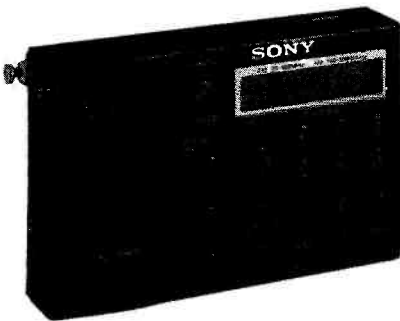

**ICF SW1E £145.00**

**ICF SW1S KIT £199.95**

ICF SW1E AND CONVENIENT SUPPLIED ACCESSORIES: ACTIVE AERIALS, AUTOMATIC MULTIVOLTAGE MAINS ADAPTOR, HARD CARRYING CASE  
**THE WORLD'S SMALLEST SHORTWAVE RADIO**

● FM stereo MW/LW/SW PLL synthesized tuner ● Dual conversion system ● LCD frequency read out ● Multiple tuning system ● 10 key/scan/memory ● 10 memory presets ● Cassette size case ● Clock/timer facility ● Supplied with stereo headphones, compact antenna

ALSO IN STOCK THE NEW \*SONY ICF-7600 SW\*

**\* £149.95\***

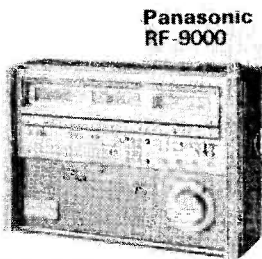

**Panasonic RF-9000**

FM 87.5-108MHz  
LW/MW/SW (1.6110-2.9009MHz)  
SW (2.9010-30.0000MHz)  
Frequency Range: LW 150.0-420.0kHz (2000-714.3m) MW 520.0-1610.9kHz (576.9-186.2m) SW 1.6110-2.9009MHz (186.2-103.4m)  
Precision: Direct Readout to 100Hz for SSB/CW/AM. Direct Readout to 10kHz for FM

**£1800.00**

Panasonic RF-B10..... £59.95  
Panasonic FR-B20L..... £69.95  
Panasonic RF-B40DL..... £124.95  
Panasonic RF-B65 (Inc Mainsadaptor). £169.95

Sony ICF SW20..... £64.95  
Sony ICF PRO 80..... £289.95  
Sony ICF AIR-7..... £209.95  
Sony AN 1 (Antenna)..... £49.95

ALL MAJOR CREDIT CARDS ACCEPTED ALSO CHEQUES AND  
POSTAL ORDERS

ALL SETS ARE GUARANTEED  
PRICES INCLUDE V.A.T.

ALL GOODS DESPATCHED WITHIN 48 HOURS



**WA 8800**

**SLIM STYLED TRAVELLERS SHORTWAVE MULTIBAND AND STEREO CASSETTE RECORDER**

● FM/MW/SW × 8.0 band ● Dual conversion circuit (SW) ● Auto reverse stereo cassette deck ● LCD clock/alarm/timer/60 minute sleep timer ● Tape counter ● Auto shut off ● Stereo recording facility ● Built-in Stereo speaker ● Stereo mic supplied ● DC in socket ● Black finish

**\* £199.95\***

**NEW ARRIVAL:— SONY CRF-V21**

● FAX/RTTY/Satellite/Weather FAX ● Frequency range 9kHz-29.9999MHz ● Sat. 137.62-141.12MHz ● Up to 1.691GHz/1.6945GHz using ANP1200 (optional antenna) FM-76MHz-108MHz

**P.O.A.**



# SEEN & HEARD

vast majority are correct.

For those interested in direct weather satellite reception, these modes are also covered with frequencies and schedules for the Meteosat, GMS and GOES series.

A section giving the addresses of many of the National Weather and Press agencies this is particularly useful for those who like to QSL.

The final section of the FAX Guide comprised some 280 pages of sample FAX charts. This may at first seem rather a waste of space but in fact the charts can be quite useful for recognising particular types of information. A major change with this edition of the guide is that a number of high quality original charts have been included. These are very handy for comparing the quality of your own received images with that of the original.

Overall the new *Guide to Facsimile Stations* will, I'm sure, appeal to all FAX enthusiasts. To obtain your copy see the *Short Wave Magazine* Book Service. Thanks to Joerg for supplying the review copy.

## Utility Log

Further to my recent mention of utility logging systems, **Trevor Rowell** of Catterick Garrison has sent me details of his computer logging system. Trevor is obviously a keen programmer and his written his own database system specifically to handle his utility logging requirements.

The program has been designed to run on IBM PCs or compatibles with a minimum of 256K RAM and a CGA video card. A hard disk and mouse are recommended but it will run on a single floppy drive machine. Just for the record, it runs perfectly on my Amstrad PC-2086.

The data entry screen has been well laid out and is rather like filling in a form with boxes for the mode and baud rate etc. This has the advantage of speeding up data entry, particularly for us one fingered typists!

There are a wide range of report printing facilities which can be based on pretty well any field in the database. This also applies to the sort

facilities which can sort on multiple fields.

The program also included a useful range of accessories to help the user maintain the database. Backup, restore and compress were all provided to handle the data maintenance activities whilst a report was available which gave the total number of stations of each mode.

For those whose computer is shared by others in the family you could even provide four levels of password protection to prevent accidental corruption of the database.

Finally, you could export all the records in dBase III format for manipulation by another package.

All-in-all a very useful package which many will find useful.

The program is being released under the shareware scheme and should be available via the Public Domain Software Library by about August. However if you would like a copy sooner you can send 5.00 directly to: **10 Albermarle Drive, Catterick Garrison, N. Yorkshire DL9 4DT.**

My thanks to Trevor for supplying a copy of the program.

## Frequency List

As usual here are a few selected frequencies from the loggings I have received this month.

The format is the usual, freq, mode, speed, shift, call sign, time and notes.

6.602MHz, CW, -, -, 7TF, 2323UTC, Bouferik R Algeria  
6.803MHz, RTTY, 50, 425, -, 2102UTC, PAP Warsaw  
8.501MHz, CW, -, -, DAL, 2345UTC, Norddeich W. Germany  
12.108MHz, RTTY, 50, 425, IRJ21, 1206UTC, ANSA  
12.265MHz, RTTY, 75, 425, -, 1509UTC, Xinhua  
16.104MHz, RTTY, 50, 425, -, 1210UTC, Diplo NCL  
18.388MHz, RTTY, 50, 425, -, 1235UTC, Tripoli Air  
18.599MHz, RTTY, 50, 425, -, 0844UTC, PL Moscow (French)  
22.537MHz, CW, -, -, FUF, 1631UTC, French Navy, Martinique

## INFO IN ORBIT

Lawrence Harris

5 Burnham Park Road, Peverell, Plymouth, Devon PL3 5QB

My son Tim and I attended the rally organised by Plymouth Radio Club and apart from it giving me a chance to see club members and buy some components I was able to meet one or two retailers of weather satellite equipment.

Chris Hornby was on the Spacetech stand demonstrating a computer-based system featuring comprehensive facilities. I would need to spend at least a day putting the software and hardware through its paces before doing a review, but Chris kindly showed me what it could do and answered all of my questions before I mentioned my involvement with *SWM*!

Spacetech retail both an Acorn Archimedes and an Atari based satellite system. The Atari was running a sequence of Meteosat whole disk infra-red pictures and they were of a high quality. The Archimedes system had some NOAA pictures stored on disk and Chris showed me the advanced nature of the software which caters for most of the requirements that I would expect of a modern system.

## Guidelines

I am going to update my own equipment soon to help me extend my monitoring activities. I do a lot of absent recording, especially when monitoring OKEAN 2, the Russian satellite, and feel that several features would be very useful. For those of you who are thinking about buying a complete receiving set-up for the first time, experience suggests to me that you should look for the following:

Check whether the system can automatically receive satellite data after programming, such as a sequence of METEOSAT frames - and ask what will happen if one frame is not transmitted? Unless the computer is battery supported, the time clock

may lose synchronisation while the electronics waits for the satellite signal and so a battery reference is essential. My own system cannot cope.

Can it be set to receive NOAA and METEOR data automatically?

Does the system adjust automatically for the best grey level response? If it doesn't you may find your pictures too light or too dark. Can it cope with satellites changing from infra-red to visible and vice versa - a severe test!

Can you add artificial colour without having to spend ages setting up colour scales?

Does the software store the image at maximum satellite resolution and can it store an entire pass? An efficient system should be able to store a complete METEOR 3 series pass which lasts about 18 minutes and should store the complete frame width, not just a part!

Does it digitise the analogue signal to 256 levels, and allow contrast stretching facilities?

How many grey levels does the monitor show? A 16-level display is very limiting - remember the framestore has 64.

Does it generate much r.f.i. or can you use it next to a satellite receiver - which is where it will get its signal from!

Will the software be updated in the future?

These are some of the questions that you may want to think about if you decide to spend real money on a quality system. Do all you can to try the system out yourself, preferably in your own home, or see the system in use in a similar environment.

If your own interest is to simply look at a selection of views of Europe and the UK on an occasional basis then remember that there are much cheaper systems available which will give excellent pictures without using

advanced signal processing facilities.

## Beginners

I receive many letters from *SWM* readers who are keen to build their own systems but don't know where to start. I understand that feeling only too well. I will put together some guidelines for beginners, those wishing to have a summary of antenna requirements, receiver features, computer or framestore sources and the other things that you need to know about. It may take a few weeks to assemble but sometime during the summer I should be able to offer summary sheets.

## Books

**Jonathan Mills** of Whitkirk wrote to tell me that he is keen on the idea of receiving weather satellite pictures and asks me to recommend a good book. The only extensive text I have on this subject is that which resides in my word processor! I would be happy to comment on published books if publishers or authors were to send me a copy for review. Meanwhile a glance around the technical literature lists reveals some possibilities.

There are books such as the one by Larry Van Horn called *Communications Satellites* which is



Fig. 1: A Meteosat picture sent in by Dave Cawley.

## GUIDE TO FACSIMILE STATIONS 1990

10th Edition - June 1990 400 Pages - GBP 19.- or DM 50.-

The FAX mode gets more and more fascinating. The recording of FAX stations on LW and SW and the direct reception of meteo satellites is no longer an esoteric science. New hard- and software connects a radio receiver directly to a laser printer. The result is press photos, satellite pictures and weather charts with the superior resolution of more than 2000 picture elements per scan line.

The new edition of our FAX GUIDE contains not only the usual up-to-date frequency lists and transmission schedules, including those of Bracknell Meteo and Royal Navy London. It informs you particularly about new FAX converters and programs on the market, and includes the most comprehensive international survey of the "products" of weather satellites and FAX stations from all over the world. More than 300 sample charts and pictures were recorded in 1989 and 1990. Here are that special charts for aeronautical and maritime navigation, the agriculture and the military, barographic soundings, climatological analyses, and long-term forecasts which are available nowhere else. Additional chapters cover:

- List of 389 frequencies - from VLF to UHF - monitored in 1989 and 1990.
- Exact schedules of 98 FAX stations on 357 frequencies.
- Comprehensive list of geostationary and polar-orbiting meteo satellites. Schedules of GMS (Japan), GOES-East and -West (USA), and METEOSAT (Europe).
- Technique of FAX transmission. International regulations.
- Lists of abbreviations, addresses, and call signs. Test charts.

Further publications available are GUIDE TO UTILITY STATIONS (16th edition) as well as RADIOTELETYPE CODE MANUAL and AIR AND METEO CODE MANUAL (10th/11th editions). We have published our international radio books for 20 years. They are in daily use at equipment manufacturers, monitoring services, radio amateurs, shortwave listeners and telecommunication administrations worldwide. Please ask for our free catalogue, including recommendations from all over the world. All manuals are published in the handy 17 x 24cm format, and of course written in English.

Do you want to get the TOTAL INFORMATION immediately? For the special price of GBP 87/DM 230 (you save GBP 15/DM 40) you will receive all our manuals and supplements (altogether more than 1500 pages!) plus our CASSETTE TAPE RECORDING OF MODULATION TYPES.

Our prices include airmail postage to everywhere in the world. Payment can be by cheque, cash, International Money Order, or postgiro (account Stuttgart 2093 75-709). Dealer inquiries welcome - discount rates and pro forma invoices on request. Please mail your order to:

**Klingenfuss Publications**  
Hagenloher Str. 14, D-7400 Tuebingen,  
Fed. Rep. of Germany Tel: ++49 7071 62830

## SCANNER OWNERS

'Listen-in' when you are 'out' with the amazing AUTO-VOX

This simple VOX switching unit fits between any receiver with a squelch control and a tape recorder, automatically turning the tape on and off as signals are detected. The AUTO-VOX will fit inside many base scanners!

Kit with full parts and instructions **£9.95** Ready built and tested **£19.95**  
Prices incl. P&P.

★ Return to a neatly compressed tape of all the action ★

P Beckett 3 Pasture Close, Whitmore, Staffs ST5 5DQ

## MEDIUM WAVE LISTENERS

DO YOU ENJOY DXING THE MEDIUM AND LONG WAVE BANDS? THEN **MEDIUM WAVE NEWS** IS FOR YOU. THE ONLY SPECIALIST MAGAZINE FOR THE MW/LW LISTENER IS AVAILABLE BY SUBSCRIPTION FROM: **THE MEDIUM WAVE CIRCLE, 137 HAMPTON ROAD, SOUTHPORT, MERSEYSIDE PR8 5DY** (SAE for full details, or for sample copy of magazine send 60 pence in stamps or 2 IRCs)

**WE ARE MOVING!**

## GAREX ELECTRONICS

With effect from early August we are moving to new and larger premises at South Brent, Devon conveniently located just off the main A38 road between Exeter and Plymouth.

All visitors, both locals and holidaymakers, will receive a warm welcome at the retail counter (open 10am - 5pm, Monday to Friday.)

Please direct all orders, enquiries and service work to the new address from 6th August.

Details of the full product range can be found in earlier editions of this magazine.

**GAREX ELECTRONICS**  
Station Yard, South Brent, Devon, TQ10 9AL  
Tel: (0364) 72770 Fax: (0364) 72007

# C.M. HOWES COMMUNICATIONS

## NEW! ACTIVE ANTENNA FOR SCANNERS

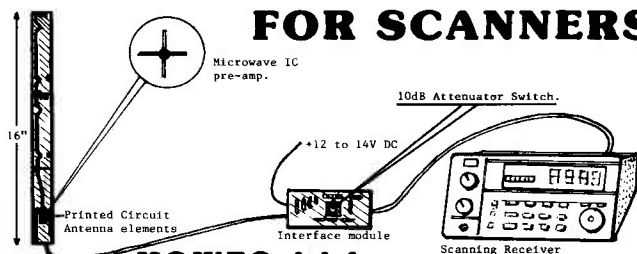

### HOWES AA4

The new **HOWES AA4** Active antenna gives full coverage from 25 to 1300MHz. It is designed to be the ideal solution for those requiring a compact, broadband antenna for use with scanning receivers. The AA4 features advanced technology with a low noise microwave IC as the active element.

- \* Fully broad-band covering 25 to 1300MHz
- \* Low noise microwave IC (NF <3dB) Over 15dB gain.
- \* Third order intercept +15dBm at 500MHz.
- \* Coax powering 12 to 14V DC at less than 20mA
- \* 10dB switched attenuator on the receiver interface board.
- \* Antenna elements ready formed on printer circuits for easy construction. Size approx 16 inches long, 1.2 inches wide.
- \* Easy to build kit, or ready built modules.

If your scanner reception could benefit from the addition of a remotely located broad-band antenna with built in pre-amplifier, or you would like a much neater, more compact alternative to the large, ugly discone types, then the **HOWES AA4** could be just the job! Excellent performance in a small space!

**AA4 kit: £18.80** Assembled PCB modules: **£24.90**

### AA2 ACTIVE ANTENNA for 150kHz to 30MHz.

The **HOWES AA2** is the active antenna to use with a general coverage HF receiver. Broad-band performance that does not tail off at the higher frequencies. The neat compact answer for those with limited space, holiday use, mobile operation etc. Two selectable gain settings, local or coax powering (12 to 14V), easy to build, and much liked by customers!

**AA2 kit: £7.50** Assembled PCB module: **£11.50**

Mail order to: **EYDON, DAVENTRY NORTHANTS NN11 6PT**  
Tel: 0327 60178



### HOWES RECEIVER KITS

We produce a range of easy to build receiver kits which offer a level of performance which is quite amazing for their simplicity. Amateur stations from all over the World can be heard with our **DXR10 three band receiver**. In fact you would be hard pressed to hear any more SSB and CW stations on these bands with even the most expensive sets!

All our receivers have plenty of audio output to drive a loudspeaker, and operate from 12 to 14VDC. There is a full range of accessory kits, these include extra filters, "S meter", and digital readout. We also have companion transmitter kits for all our amateur band receivers, so you can convert your receiver into a transceiver at a later date.

To make things easy for the constructor we have optional **hardware packages** (case, dial, knobs, sockets etc.) to go with our receiver kits (which contain the electronics).

		KIT	ASSEMBLED PCB
<b>DXR10</b>	SSB and CW receiver for 10, 12 & 15m bands	<b>£24.90</b>	<b>£36.90</b>
<b>DcRx</b>	Single band receiver for 20/30, 40 or 80m	<b>£15.60</b>	<b>£21.50</b>
<b>DcRx54</b>	5.4MHz HF Airband receiver	<b>£15.60</b>	<b>£21.50</b>
<b>MBRX</b>	HF Marine band receiver, inc. 80 & 160m	<b>£29.90</b>	<b>£44.90</b>
<b>TRF3</b>	Shortwave Broadcast TRF receiver	<b>£14.80</b>	<b>£20.20</b>
<b>DCS2</b>	"S meter" kit for all our receivers	<b>£7.90</b>	<b>£11.90</b>
<b>CSL4</b>	Sharp SSB and CW filters for our receivers	<b>£9.90</b>	<b>£15.90</b>
<b>ASL5</b>	Sharp SSB and CW filter for FRG7, R1000 etc	<b>£14.90</b>	<b>£22.50</b>
<b>CTU30</b>	HF bands & 6M ATU for any RX or 30W TX	<b>£27.90</b>	<b>£33.90</b>

**DXR10 or TRF3 Hardware package: £14.00.** DcRx hardware: **£15.50**  
MBRX hardware: **£26.00**

Please add **£1.00 P&P** to your total order value.

There are many more kits in our range. Please send a good size SAE for a copy of our free catalogue. Sales and technical advice are available by phone during office hours - you can actually speak to people who know what they are talking about!

All **HOWES KITS** contain a good quality printed circuit board with screen printed parts locations, full instructions and all board mounted components. Our kits offer the challenge and satisfaction of home construction, with the reassurance of help if you need it.

**73 from Dave G4KQH, Technical Manager**



# SEEN & HEARD

a useful introduction and reference to all that is going on. It costs about £14 from various retailers. It is not a specialised book on weather satellites and it does contain some errors but I like it because of its wide coverage.

If you would like a list of satellite oriented books you can send a large s.a.e. to Geoffrey Falworth at 15 Whitefield Road, Penwortham, Preston PR1 0XJ who stocks these items. Geoffrey has been providing me with various types of satellite data, such as Kepler elements and launch manifests - the lists of expected launches published by agencies such as NASA.

Jonathan asks whether he could use a Dragon 64 computer and a hand-held scanner such as the Realistic PRO-34. I don't know of software for the Dragon computer to decode weather satellite data, though possibly the Dragon User Group may know of some.

The PRO-34 receiver mentioned by Jonathan will be able to hear a.p.t. signals in the 137MHz band but such units are not designed to receive and process the whole of the signal being transmitted. These receivers usually have a narrow bandwidth, perfect for other purposes but not for providing pictures. So although they can tune into the satellites the resulting picture will lack detail and quality. That is why weather satellite receivers are specially made and cost between £50 and £600 depending on what extra features you want to have.

## Offers

For the latest set of Kepler elements just send me an s.a.e. for a printout. If you would like some METEOSAT/NOAA recordings to try your system out, please send a pre-paid cassette tape. SWM reader **Chris Butlin** wrote from Dunstable to request some METEOSAT and NOAA data to be recorded on his cassette. Chris didn't describe his receiving or decoding system but I hope that the recordings were of help. Several other readers should have had their tapes back OK.

## More letters

**James Northam GW1XBF** of Sully told me that a new phasing harness

fixed his Jaybeam antenna, which previously had a problem. I had the same problem some years ago resulting in my getting poor satellite signals when they were over to the west. Eventually I took down the antenna and found a break in one of the phasing harness cables. Jaybeam replaced it immediately and the improvement was dramatic. James comments that the signal is still weak and so he proposes to re-install his Dartcom pre-amp.

Most receivers will cope with the signal if the cable run is within about 15 metres and of good quality with well-made connecting plugs. If the pre-amp has to be re-installed be prepared for out-of-band signals, such as the local paging transmitters, to cause problems. Dartcom make a good quality unit but the receiver may not cope well.

James comments that his framestore seems to be generating hash after 2 years of use. Mine does occasionally as well, and I believe it is caused by poor earthing. He also asks whether any reader knows of a circuit that can transfer data from the framestore to a BBC-B computer and back?

James asks what antenna I use. I have a Jaybeam on the roof which feeds about 17 metres of UR67 cable and I am very pleased with the system's sensitivity. I also have a Timestep unit as a backup.

Final, for **David Bolton** who recently asked whether a CPC464 could be used as a decoder. James reminds me that Maplin's Mapsat system uses it and produces 16 grey levels. Thanks for that letter James!

## Future Shuttles

Here's a brief summary of the next planned Shuttle missions provided for me by Geoffrey Falworth:

1990 July 30 STS-38 Atlantis, payload Lacrosse 2.

August 29 STS-40 Columbia, payload Spacelab Life Sciences 1.

October 5 STS-41 Discovery, payload Ulysses 1.

November 1 STS-37 Atlantis, payload Gamma Ray Observatory 1.

December 12 STS-42 Columbia, payload International Microgravity Laboratory 1.

## Signal Identified

In previous columns I have mentioned the various satellite signals that can be heard in the band 136 to 138MHz, apart from the weather satellites. My log book records several regular frequencies including UK6 on 137.56MHz (due to re-enter in a few months) and one on 137.44MHz. I measured the period of this satellite as 93 minutes and Geoffrey Falworth has identified it as ARYABHATA 1 which is an Indian satellite carrying a transmitter made in the USSR. My thanks to Geoffrey for this research.

## Predictions

Several writers including **Lester Jones** of Merseyside have asked me to include more pass predictions so here is another set, this one for Saturday August 4th. The times (given in UT) should be within a couple of minutes or so but the Russian satellites may either change frequency or be off so remember these possibilities.

The format is satellite identification, acquisition of signal, loss of signal, maximum elevation of satellite in degrees and whether to the east or west, and finally its direction of travel - either north or south-bound.

Saturday August 4

Satellite	AOS	LOS	Maxel	Dir
Met 2/16	0844	0859	29W	SB
NOAA 10	0852	0906	46W	SB
NOAA 11	1220	1233	27E	NB
NOAA 11	1400	1414	59W	NB
Met 3/3	1546	1606	69E	NB

## OKEAN-2 Predictions

Listen in on 137.40MHz as follows:  
August 4 1709 to 1720UTC 23E SB  
August 6 1626 to 1636UTC 14E SB

You must have a clear easterly horizon and of course OKEAN must be on!

## WX Satellite Activity

During recent weeks the only change in the pattern of transmissions has been the increase in the number of pictures received from OKEAN-2. My records show several days when two pictures have been received, always the first easterly pass, north-bound

then south-bound. Quality has been very good and there have been visible, radar and microwave images.

The NOAAs remain operational and well illuminated passes can be seen during the evening NOAA10 pass and the overnight NOAA9 passes.

At the moment (June) only two METEORS are in normal operation - METEOR 2/16 and 3/3, both showing streaky images near the poles probably caused by sticking apertures.

METEOSAT 4 continues to provide pictures of excellent quality and includes some frames taken by GOES-E which is now out of range due to drifting when its fuel ran out.

## China WX?

My spy tells me that the new Chinese WX satellite FENG YUN 2 should be launched in July so scan around for it!

## Frequencies

NOAAs 9 and 11 on 137.62MHz  
NOAA 10 on 137.50MHz  
METEOR 2/16 on 137.85MHz  
METEOR 3/3 on 137.30MHz  
OKEAN-2 on 137.40MHz  
FENG YUN 2 ?? Try 137.04MHz

## Picture

This month I am including a METEOSAT picture sent by **Dave Cawley** from Newmarket who is working on new satellite systems and promises to visit me.

## New Series

I hope to find space to give some new information about the Russian satellites having received some technical literature on the METEORS from the USSR State Committee for Hydrometeorology.

Your letters are most welcome and I want to continue to give the current satellite status each month so perhaps next time I'll squeeze the first piece in!

**Stop Press: Listen for the new Russian WX satellite on 137.???MHz, full details will appear next month.**

## BAND II DX

Ron Ham

Faraday, Greyfriars, Storrington, West Sussex RH20 4HE

During May I recorded just 0.66in of rain, so it came as no surprise when one of the television weather presenters said, on June 1, that this May was the 'driest for over 100 years'. The average noon pressure during the month prior to June 18 was 30.2in (1022mb) with highs of 30.5in (1032mb) from May 26 to 29 and lows of 29.9in (1012mb) on June 3 and 7.

I heard thunder on the 1st, a number of static discharges on the 9th and my rainfall measurement between the 1st and 19th was 1.69in, a great improvement on the May figure. Reasonable tropospheric

openings occurred on May 25 and 29, however, the best news for DXers was not the predominantly fine weather but the start of the 1990 Sporadic-E season toward the end of the month.

## Sporadic-E

While using my ex-military R216 v.h.f. communications receiver, fed with a chimney mounted dipole, at 1917 on May 28, I counted about 40, very strong signals, from a variety of East European broadcast stations between 66 and 73MHz and heard television synchronising-pulses on Chs. R3

(77.25MHz) and R4 (85.25MHz). A few such stations appeared between 68 and 72MHz, plus about four in Band II, around 1300 on June 1. **Simon Hamer** (New Radnor) also heard a good number of these broadcasters from the east at his home in mid-Wales on June 1.

During an extensive opening at midday on the 8th, I stopped counting these East Europeans at 60, added 5 foreign voices between 91 and 98MHz and, in addition to the sync-pulses for Chs. R3 and R4, I heard the sound for Chs. R3 on 83.75MHz and R5 on 99.75MHz. At 1242 on the 8th, **Terence Burke** (Bradford), switched

on his Sony ICF-2001D receiver and heard Romanian TV sound on Ch. R3 and those buzzing vision pulses on Chs. R3 and R4.

A similar event was in progress when I fired up the R216 around 1800 on the 18th and 19th and counted over 40 and 50 EEs respectively in the 66-73MHz band and on both days heard the sync-pulses on Chs. R3 and 4 plus the television sound from Ch. R3. It could be worth while to allocate a few of your scanner buttons to these broadcast channels during the mid-summer months and see what you can identify when such disturbances are in progress.

# spacetech **ATARI WEATHER SATELLITE STATION**

The Weather Satellite Reception system developed by Spacetech for the Archimedes which won the 1989/90 BETT Educational Technology Gold Award is now available for the Atari range of computers. Entirely new software provides the following powerful features:

- Compatible with European, Soviet and American satellites
- Time lapse animation of weather systems
- Entire image stored in maximum spatial resolution
- Automatic "hands-off" data collection
- 13 frames stored on 520ST, 34 on 1040ST
- False colour or 4 bit greyscale
- Analogue zoom with fast pan over entire image
- Infra-red and visible light images with cross-fade
- Frames may be exported to Art packages
- Printer support ● Many powerful utilities



Spacetech currently have systems installed in Schools, Colleges and Universities all over the world. Their systems are also used by weather agencies, television stations and, of course, by enthusiasts. There has been no compromise in the development of the Atari system and for the first time, the home computer user can afford a truly professional weather satellite system.

There are two purchase options available: the software package on its own (for the DIY hardware buff) at £130.43 and the software and decoder at £239.13. In addition Spacetech has a range of high quality VHF and SHF satellite receivers and antennas.

Trevor Atwell, writing about Spacetech's system in A&B Computing said:

"It is difficult to imagine an alternative package which could offer as much as this does or to think of anything more that could be asked of it. A tremendous amount of thought has obviously been lavished on the design and the results are worth every penny asked. See it before spending up to ten times as much on an alternative!"

...and a meteorologists view from Philip Eden (in Archive):

"Compared with the various industry-standard systems I have previously used, it is better and cheaper. Sometimes you can say one and sometimes you can say the other, very rarely both"

This system is now available for the Atari ST range and will be demonstrated at the 16 bit Computer Show along with our wide range of Space-Science resources. A price list and further details is available on enquiry, as well as demonstration discs.

**DEMONSTRATION DISCS:** ANIMATION £5.00 each 520 or 1040 STILL-FRAME (please state)

Please note: A suitable receiver and antenna is also required, although the system is compatible as an upgrade to existing equipment. Only weather satellite receivers are suitable, not satellite television equipment.

**spacetech** 21 WEST WOOLS TEL. 0305 822753  
PORTLAND DORSET FAX. 0305 860483  
DT5 2EA UK

## NEW

### WEATHER SATELLITE RECEPTION

APT-1 decoding module enables all weather satellites to be received on any FAX system. Includes full AGC and signal-derived synchronisation for perfect pictures from any source. Plugs into RX-8 system direct. £59 or £39 if ordered with RX-8.

#### RX-8 for the BBC Computer

FAX charts & photos to screen and printer, HF & VHF PACKET, Colour SSTV, RTTY, AMTOR, CW, ASCII, UoSAT.

Receive them all with every possible feature, superb performance and ease of use. Full printer & disc support. Complete system of hardware interface, EPROM, handbook and all connecting leads only £259. **DISCOUNT** for RX-4 users. Send for full information. Reviewed in Oct '89 Ham Radio Today & March '90 Amateur Radio.

#### RX-4 RTTY/CW/SSTV/AMTOR RECEIVE

Performance, features and ease of use make this still a best-seller. Text and picture store, disc and printer support. Needs TIF1 interface. **BBC, CBM64** tape £25, disc £27. **VIC20** tape £25. **SPECTRUM** tape £40, + 3 disc £42 inc adapter board (needs TIF1 also) or software-only version £25.

**TIF 1 INTERFACE** Optimum HF and VHF performance with our software. 4-pole filtering and computer noise isolation for excellent reception. Kit £25, ready-made, boxed with all connections £40. Available only with software.

Also **MORSE TUTOR** £6, **LOGBOOK** £8, **RAE MATHS** £9 for **BBC, CBM64, VIC20** and **SPECTRUM**. **BBC LOCATOR** with UK, Europe, World maps £10. All available on disc £2 extra.



**technical software**



Fron, Upper Llandwrog, Caernarfon LL54 7RF  
Tel: 0286 881886

## PC GOES

### The PC GOES is a complete Weather Satellite program and demodulator system for the IBM PC™ family of computers.

- \* Processing of METEOSAT, GOES, NOAA and METEOR images.
- \* Supports Hercules, CGA, EGA, VGA with up to 256 colours or grey levels.
- \* Orbital Prediction and Realtime Plotting of tracks for up to 10 satellites.
- \* Automatic Image Capture Scheduler for date, time and frames.
- \* Storage and Retrieval of images from disk.
- \* Image Zoom, Pan, Reversal and False Colourisation.
- \* Slide Show Animation and Export to PCX files.
- \* Greyscale Printer output to all popular printers.

**PRICE ONLY £199.00** inc. VAT. P&P £2.75

## PC HF FAX

### The PC HF Facsimile is a complete FAX reception system for the IBM PC™ family of computers.

- \* Display in grey scale or colour.
- \* Printer output in half tone.
- \* Supports Hercules, CGA, EGA, VGA.
- \* IOC rates 60, 90, 120, 180, 240 LPM
- \* Storage/Retrieval from disk
- \* Automatic Image Capture.
- \* Image Zoom, Pan, Reversal, Export.
- \* Slide Show Animation.
- \* Menu Driven Software.

**PRICE ONLY £99.00** inc. VAT. P&P £2.75

## PC SWL

### The PC SWL is a complete package allowing reception of MORSE CODE, RTTY, and FEC.

- \* RTTY Baudot 45,50,57,75 and 100 Baud.
- \* RTTY ASCII 75,110,150 and 300 Baud
- \* CIR 476 Codes FEC, SELCAL and NAVTEX.
- \* MORSE CODE 1 to 40 WPM.
- \* Automatic Calibration and Code Recognition.
- \* Unattended Capture and Printing.

**PRICE ONLY £99.00** inc. VAT. P&P £2.75

To introduce our latest shortwave communication product we are offering a special package price.

Order PC HF FAX and PC SWL together for **ONLY £178.00 INC VAT, P & P £2.75**

All units come complete with demodulator cable and comprehensive manual. They are simple to connect using no external power or expansion slots.

**CALL TODAY FOR FULL DETAILS.**

## COMAR ELECTRONICS



1A Birmingham Road,  
Cowes, Isle of Wight PO31 7BH  
Tel: 0983 200308





# SEEN & HEARD

## Tropospheric

Looking back to the good conditions on April 30/May 1, **Leo Barr** (Sunderland) heard many continental stations, at varying strengths with some in stereo and positively identified signals from West Germany (the programmes *Nachrock* and *Nachtexpress* from Sender Freies Berlin) and Holland (Nos Programmes 1&3) and BBC Radios One, 4 from Weardale, Northants Scotland and York and from the IBA, Max AM and Metro Radio. Leo, using his AOR-800E scanner, also noted good reception of amateur signals on the 144 and 432MHz bands throughout both evenings which proves that tropospheric conditions at that time were enhancing the range of signals from at least 80 to possibly more than 450MHz.

**Barry Bowman** (Prestwich) logged Capital FM, Century Radio and 98 FM from Ireland during the morning of May 5 and Simon Hamer heard a few West German stations on the 14th and programmes from Denmark, Norway and Sweden on the 25th.

"As an avid listener to the Radio 4 evening news and current affairs programme *PMI* was amazed to hear Val's (of *Blue Peter*/Elephant fame) voice booming from my handy portable radio on the evening of the 29th of May," wrote **Andy Mepham G4CBZ** from Rottingdean and when I tell you that Andy received this transmission, around 94MHz, from his parents house, Fig. 1, on the south coast of Spain, some 50km east of

Gibraltar you will see the importance of his report. "The usual Spanish station which occupied that space on my dial was completely squashed by Radio 4," said Andy.

## Info

**Peter Walduck** (Milton Keynes) has been listening to his fairly new local station Horizon Radio on 103.3MHz and tells me that this is 'spin-off' of Chiltern Radio. Peter's letter reminded me that before concluding my work for this month on June 19, I must check the Engineering Information on the BBC's CEEFAX, page 698, and the IBA's ORACLE, pages 297 (ITV) and 697 (Ch.4), to see what other Band II stations were in the pipe-line for us to look for when conditions are right.

By the time you read this the BBC should be on from Kidderminster on 104.6MHz, Walsden South (W. Yorkshire) with Radios 2, 3 and 4 on 88.4, 90.6 and 92.8MHz respectively and in September, from Chippenham (Wiltshire) with Rs 1, 2, 3, and 4 on 98.4, 88.8, 91.0 and 93.2MHz. They will also be preparing transmissions for Radio Berkshire from Hannington (104.1MHz), Henley (94.6MHz), Reading (104.4MHz) and Windsor (95.4MHz). The IBA have Radios Harmony (102.6MHz) and Wear FM (103.4MHz) coming on from Allesley Park and Haining respectively in August and Kiss FM (100.0MHz) from Croydon in September. Don't forget readers to 'page 'em up' because teletext is a good service and very useful to us.

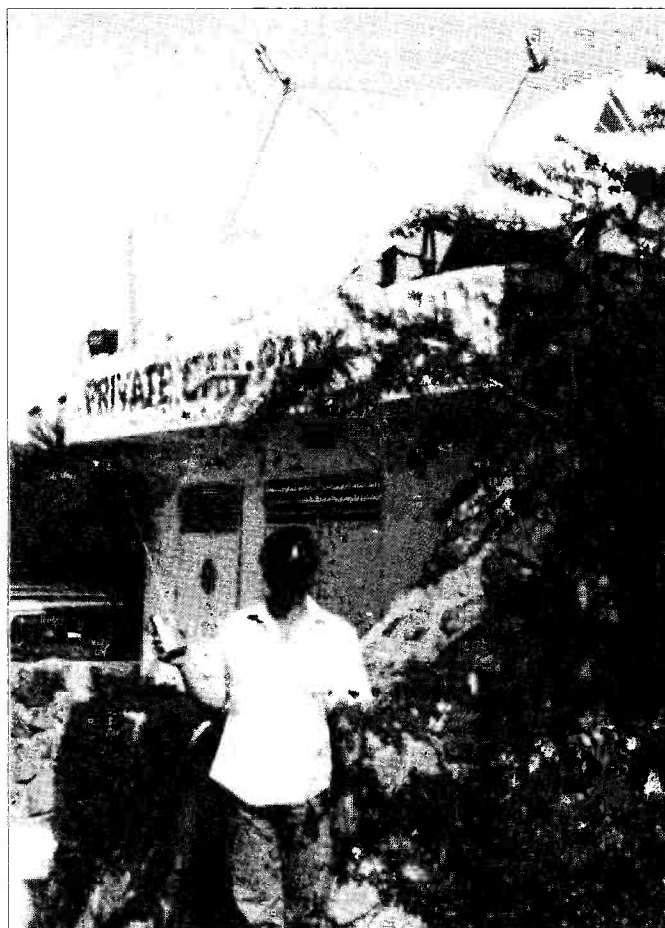

Fig. 1: Andy Mepham at his parents' house on the south coast of Spain.

Deadlines: August 17, September 17 and October 19

## TELEVISION

Ron Ham

Faraday, Greyfriars, Storrington, West Sussex RH20 4HE

## Sporadic-E

This month, thanks to my new and old contributors, I have the first reports of the beginning of the 1990 Sporadic-E season and how it has effected television signals in Band I and sometimes in Band II.

"Fortunately Sporadic-E has been showing signs of perking up these past few weeks," commented **David Glenday** (Arbroath) in his letter of June 6. Although until then David's DX was mainly from Italy, Spain and Yugoslavia he did receive pictures from Poland and the USSR and such unidentified captions as 'Kultur Journal' (Spitting-Image type puppets) on Ch. R1 (49.75MHz) and '7 SINN' on Ch. E4 (62.25MHz) between 2000 and 2007 on May 31.

From a seasoned television addict to a couple of welcome and enthusiastic newcomers to DXTV, **Barry Bowman** (Prestwich) and **Terence Burke** (Bradford) who both waited patiently for the first of the 1990 events and were pleasingly rewarded. Believe me lads, you will be fully experienced TV DXers by the time this season ends in September and will be passing your know how on to others.

Barry, a Band II enthusiast, bought

a D-100 converter for his Philips receiver last September and had to wait until this May to see his first major TV opening. He saw a variety of programmes, such as a documentary, films, news and weather, from Spain (TVE) during the Sporadic-E disturbances on days 25, 26, 28 and 29 and, on the 31st, he logged a picture from the USSR "at remarkable strength". Barry received programmes from the USSR again on June 1 and 8 and watched an American film from Czechoslovakia (CST1) and the French open tennis from Iceland on the 2nd plus news and an American 'Soap' from Sweden on the 8th.

Following his good start Terence wrote, "Although I've been interested in short-wave radio for about 10 years now, it is only recently that I have had a chance to try DXTV." A few weeks before his letter on June 8 he acquired a Panasonic TR3000G receiver and connected it, temporarily, to his Sony AN-1 h.f. active antenna. His efforts for trying paid off during the Sporadic-E openings on May 11, 15, 21, 26 and 28 and June 1 and 8 when he served his DXTV apprenticeship by seeing captions, logos, a variety of programmes and test-cards, in Band I, from stations in Austria (ORF),

Czechoslovakia (CST and SR1 TV Bratislava), West Germany (ARD), Italy (RAI-UNO), Poland, Spain (TVE1), Sweden (Kanal1 Sverige), the USSR (news captions BPEMR) and Yugoslavia (JRT Belgrade).

In New Radnor that long established viewer, **Simon Hamer**, identified pictures from Albania (RTSH), Algeria (RTA), Austria (ORF), Czechoslovakia (CST1 Bratislava), Finland (YLE), West-Germany (ARD1), Greece (EPT), Hungary (MTV), Iceland (RUV), Italy (RAI-UNO), Morocco (RTM), Norway (Greipstad), Poland (TVP), Portugal (RTP), Romania (TVRL), Spain (TVE1&2), Sweden (SVT1), Switzerland (+PTT/SRG-1), the USSR (TSS) and Yugoslavia (JRT) spread over May 15, 21, 28, 29, 30 and 31 and June 1, 2, 3, 6, 7, 8 and 9. Among the highlights in Simon's catch, if there could be anymore, he were pictures of Mr Gorbachou in the USA as high as Chs. R6 (175.25MHz) and R7 (183.25MHz) in Band III on June 1, signals from Algeria on Ch. E7 (189.25MHz), in Band III again and a 525-line North American transmission on Ch. A2 (55.25MHz) on June 3 and pictures from the USSR plus Cyrillic captions from another station on Ch. R5 (93.25MHz), in Band II, on the 8th.

Between May 11 and June 2, **Mike Bennett** (Slough) saw adverts from Hungary (TV1) programmes about farming from Poland (TVP), football and news from Italy and the USSR and test-cards from Czechoslovakia (1SR-P), Iceland (RUV ISLAND) in full colour, the Norwegian regionals (Bagn, Melhus, Hemnes, Kongsberg and Steigen), Portugal (RTP Porto) Sweden (Kanal1 Sverige), Yugoslavia (JRT RTB) and the USSR. Mike has seen adverts from Hungary, Romania's new identification, a circle with '2 Television Romania' inside and the national flag over the top and 'Olivete' scribed in the lower half of a Soviet clock. During the mornings of May 18 and June 1 **John Woodcock** (Basingstoke) received adverts from Italy (RAI-UNO) and from Spain (TVE) and Sweden (Kanal1 Sverige) on May 31.

He also reported unidentifiable pictures in Band I on May 24 and June 4 and 5. "The openings I have seen have been short and quick, but interesting," wrote John for the month prior to June 7. Toward the end of the Sporadic-E opening between 1900 and 2000 on May 28, I received a film and a news programme, presumably from the USSR, on Chs. R1 and 2 and with my

# SEEN & HEARD

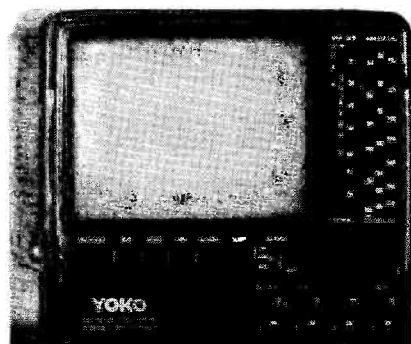

Fig. 1: Yoko TV.

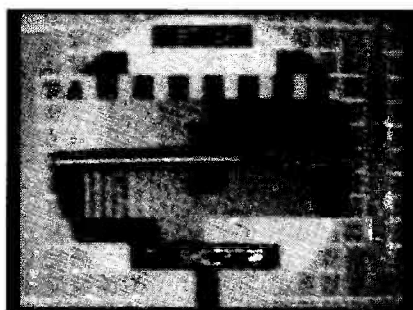

Fig. 2: Albania.



Fig. 3: Malaysia.



Fig. 4: Malaysia.

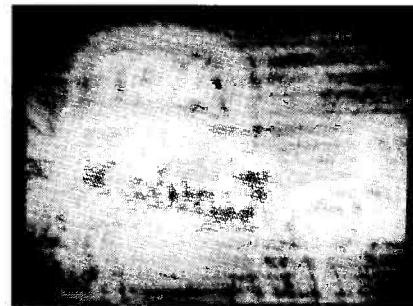

Fig. 5: Malaysia.



Fig. 6: Yugoslavia.

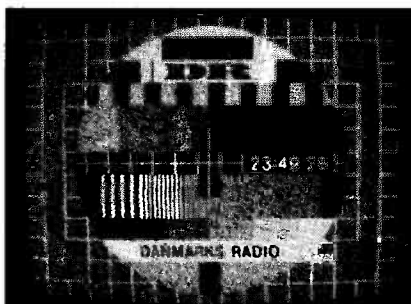

Fig. 7: Denmark.

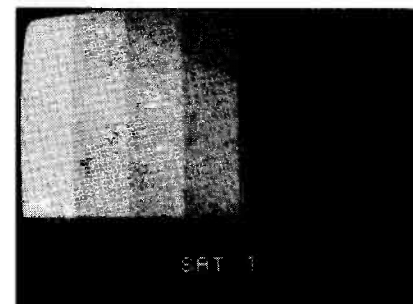

Fig. 8: W. Germany.

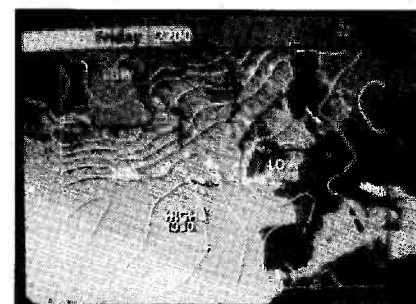

Fig. 9: Weather Map.



Fig. 10: Grampian.



Fig. 11: SSTV.

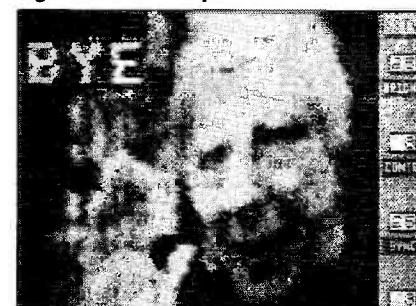

Fig. 12: SSTV.

ex-military R216 v.h.f. communications receiver I heard television synchronising pulses, frequently fading, on Chs. R3 (77.25MHz) and R4 (85.25MHz). Among the DX logged by **Bob Brooks** (Great Sutton) was the 'CST' logo from Czechoslovakia, clock captions from Poland, the USSR, Germany (ARD) and Spain on May 15 and 31 and June 2 and 5 respectively, programme details ('DAG1 and RAS2) followed by a childrens programme from Iceland (RUV) on June 5, news from the USSR on the 31st, Germany (ARD/ZDF) on June 1, 2, 3 and 4 and Italy (TGI) on the 2nd, idents such as 'MADRID', 'MTV' and 'PORTO' on May 31 and June 2 and 5 respectively and test-cards from Czechoslovakia (1SR/ P) on June 4, Scandinavia on May 7, 16 and 31 and June 5 and Yugoslavia (RTV LJUBANA) and the USSR on June 1.

When the intense Sporadic-E

opening on the 8th was at its peak around 1330, I logged very strong test-cards from Poland on Chs. R1, R2 and R3 and found that R3 could be tuned in on my Yoko TVC8M, Fig. 1, in the un-marked section of Band I (with the pointer between 11 and 12). I proved this by comparing any changes in signal with those received on the D100 converter feeding my Panasonic NV430 video recorder and the strength of the associated synchronising pulses coming in on my R216. Reasonable signals were also received on the latter from the sound of Chs. R3 (83.75MHz) and R5 (99.75MHz). I saw the caption, in English, 'Strom Moscow USSR' on Ch. R1 at 1157 on the 3rd, the Russian 'Optic' test-card on Ch. R1 mixing with pictures on Ch. E2 at 1145 on the 8th and when I checked Ch. R1 again at 1300 on the 12th, there appeared for a short while, a Russian clock showing 1600. I briefly saw a news

programme on Ch. R1 at 1830 on the 16th and pictures mixing on Chs. E2 and R1 and most likely news on Chs. R2 and 3, at 1800 on the 18th. At the same time I also heard Ch. R3 sound on 83.75MHz and R4 synchronising pulses.

## Picture Archives

My thanks are due to fellow journalist **Garry Smith** (Derby) for the photograph of the Albanian test-card, Fig. 2, scribed RTSH TV SHQIPTAR which he logged during one of the 1989 events, **Lt. Col. Rana Roy** (Meerut, India) for the typical DXy pictures that he received from Malaysia (TV3), on Ch. E2, during the evenings of October 25, 26 and 30, 1989, Figs 3, 4 and 5 respectively and to David Glenday for the caption he identified from Yugoslavia last August 10 on Ch. E3, Fig. 6 and for the test-patterns that he received during a

tropospheric opening from Denmark and West-Germany on Chs. E10, Fig. 7, and E48, Fig. 8, on July 6, 1989. Next day he saw the BBC1 weather map, from Chatton on Ch. E39, Fig. 9 and commented, "despite the low pressure, there were still good signals being received from Denmark and West Germany." Then David added, "Readers may like to see that UK television is received on the continent as well as vice-versa," when he sent a copy of Grampian TV's test card, Fig. 10, photographed in Rotterdam, on Ch. E24, by **Gosta van der Linden**.

## Tropospheric

Mike Bennett was among those who lost his u.h.f. antenna and rotor during the January gales and John Woodcock received negative pictures in Band III from France on May 12, 18, 20, 21, 24 and 25 and June 1 and 2.



# RADIO AMATEURS EXAM? PASS FIRST TIME!

**Before you enrol check the benefits of  
RRC'S unique Home Tuition Service**

RRC has helped thousands of students to success in their examinations with this unique system of postal tuition, one which guides you, step-by-step, to qualify in the shortest possible time. Only The Rapid Results College offers you all these advantages:

- |  |   |
|--|---|
| <input checked="" type="checkbox"/> A qualified personal tutor             | <input checked="" type="checkbox"/> Free advice before you enrol                    |
| <input checked="" type="checkbox"/> Study material prepared by specialists | <input checked="" type="checkbox"/> Telephone Helpline                              |
| <input checked="" type="checkbox"/> Completely self-contained courses      | <input checked="" type="checkbox"/> Free 'How to Study' Guide                       |
| <input checked="" type="checkbox"/> Handy pocket-sized booklets            | <input checked="" type="checkbox"/> Instalment Plan                                 |
| <input checked="" type="checkbox"/> Personal study programme               | <input checked="" type="checkbox"/> Free Postage on course material                 |
| <input checked="" type="checkbox"/> Regular marked tests                   | <input checked="" type="checkbox"/> Worldwide Airmail Service                       |
| <input checked="" type="checkbox"/> Courses regularly updated              | <input checked="" type="checkbox"/> Extra tuition free if you don't pass first time |
| <input checked="" type="checkbox"/> 48 hour despatch                       |   |

## POST COUPON TODAY FOR FREE RADIO AMATEURS PROSPECTUS

Please send me my prospectus as quickly as possible.

Mr/Mrs/Miss/Ms \_\_\_\_\_

Address \_\_\_\_\_

Postcode \_\_\_\_\_



**The Rapid Results College**  
Dept. JV104 Tuition House, London SW19 4DS. FREE ADVICE 081-947 7272 (9am-5pm)  
PROSPECTUS: 081-946 1102 (24 hour Recordcall Service quoting Dept. No. above.)



**DATING**  
ELECTRONICS LIMITED  
Clayton Wood Close  
West Park  
Leeds LS16 6QE  
Tel: 0532 744822  
Fax: 0532 742872

## For products you can rely upon to give amazing results

For information on **Active Antennas, RF Amplifiers, Converters, Audio Filters, the Morse Tutor and Speech Processors** send or telephone for a free catalogue and selective data sheets as required.

All our products are designed and made in Britain. Orders can be despatched within 48 hours subject to availability.





BARCLAYCARD VISA — VISA AND ACCESS WELCOME — 

THE UP-TO-DATE NEWS & INFORMATION SERVICE FOR  
THE LISTENING ENTHUSIAST

**0898 654676**  
UPDATED EVERY SATURDAY

Calls charged at 38p per minute peak,  
25p per minute off-peak.



**RADIO LINE**

# HAVING DIFFICULTY GETTING YOUR COPY OF SHORT WAVE MAGAZINE ?

**Then place a regular order with your newsagent NOW !**

Dear Newsagent, Distributed by Seymour  
please reserve / deliver my monthly copy of SHORT WAVE MAGAZINE

NAME .....

ADDRESS .....

.....

.....

Signed .....

# SEEN & HEARD

During the good tropospheric conditions on May 14 and 25, Simon Hamer received pictures from Belgium (BRT1 & RTBF1), Denmark (DR), France (TDF), East Germany (DFF1), West Germany (ARD/WDR1), Luxembourg (RTL+), Norway (NRK) and Sweden (SVT1) in Band III and Belgium (BRT2 & RTBF2 (TELE21)), Denmark (TV2 Hedensted), France (TDF), West Germany (ARD/WEST3 & ZDF), Holland (NED2&3) and Ireland (RTE1&2) in the u.h.f. bands. David Glenday received u.h.f. pictures from Holland (NED3) on the 14th and 18th, Denmark and Holland on the 28th and West Germany (NDR3 & ZDF) on the 31st. The first indication I had of a forthcoming weather change was around 1500 on June 15 when I had

my Plustron TVR5D, with its own rod antenna, inside my car and received a strong picture from France on Ch. L9 in Band III and again when co-channel interference was prominent in the u.h.f. band around 0600 on the 18th. During that period the atmospheric pressure fell from a steady 30.3in (1026mb) on the 15th to 30.0in (1015mb) at midday on the 18th when our garden benefited by 0.42in of rain.

## SSTV

First I must apologise to **Ian Armstrong G7GVN** (Millom) for giving his call-sign letters as GUN and to **John Higgins** (Birkenhead)

who was licensed G7GUN on March 2. Sorry lads, I got the V and U mixed up. However, congrats to John on passing the RAE and wish him every success in amateur radio and to Ian who received SSTV pictures from Austria, Czechoslovakia, Italy, Lithuania and Poland during the month prior to May 24. If any of you know of an SSTV transceiver program for a Commodore C64 computer, please let Ian know. Readers hearing those 'twittering' SSTV pulses on their h.f. receivers for the first time may not realise that, in addition to exchanging call-signs and signal

reports etc., in caption form, many operators show their skills in other fields by transmitting cartoon drawings or use photographs of themselves or members of their families as shown in Figs. 11 and 12 copied by **Max Wustrau G7BLH** (Bedford) around 14.230MHz last year. There is a lot more to the subject of slow scan television than first meets the eye and I suggest that any of you who are interested should talk to someone who is active in this field, especially now that computer technology has made the receiving side a lot easier.

Don't forget to send your TV reports as well as your TV pictures to Ron for use in the column

## LONG MEDIUM & SHORT

Brian Oddy G3FEX  
Three Corners, Merryfield Way, Storrington,  
West Sussex RH20 4NS

Many listeners are spending much of their leisure time away from their listening post just now, but that need not prevent them from enjoying a little DXing while out and about, as there is a wide choice of small portables available. Despite their size, many are capable of quite remarkable performance.

Most modern car radio receivers are both sensitive and selective and therefore provide listeners on the move with an ideal opportunity to check the bands from new locations.

### Long Wave DX

Note: l.w. & m.w. frequencies in kHz; s.w. in MHz; Time in UTC (=GMT).

Some unusual variations in reception during daylight have been observed by Kenneth Buck in Edinburgh. Whilst using exactly the same equipment, he found that the signals from Kaliningrad 171; Motala 189; Oslo 216; Konstantinow 225 and Minsk 279 were noticeably weaker than during the preceding month and those from Brasov 153 and Lahti 252 were inaudible. Perhaps these effects are due to changes in the sea paths involved.

After studying the reports in this column on the variations in the reception of the broadcasts from Atlantic 252 in different areas of the UK, Graham Whiting decided to make a spot check with his Sony ICF-2001D portable during a visit to the Forest of Dean. He rated their signal as SINPO 55555. The Philips 752 radio in his car gave similar results all the way home to Leamington Spa. Although his report of perfect reception resulted in an attractive QSL and a data sheet from the station, no doubt they will also be interested in reports from the areas where reception is poor.

### MW Transatlantic DX

An absence of signals from S.America was noted by Jim Willett in Grimsby, but he did receive three broadcasts from the Caribbean area. The first to become audible was VOA via Antigua, W. Indies on 1580, which rated SIO222

at 0005. The Atlantic Beacon, Turks and Caicos Islands on 1570 was heard at 0140 as SIO222. At 0550 he noted RFO Pointe a Pitre, Guadeloupe on 640 as SIO222.

Five of the broadcasts from Canada reached Jim between 0030 and 0245, see chart. The earliest stemmed from CKLM in Laval, Quebec 1570, which peaked SIO222. Between 0210 and 0250 he also logged three signals from the USA, WCBS 880 and WINS 1010 in New York, also WBAL in Baltimore 1090. Later, he picked up a station ident from CHNR in Simcoe, Ontario 1600, it was followed by a news bulletin at 0600. At 0620 he heard WLS in Chicago on 890, but there was deep fading on the signal.

In Bristol, Tim Shirley also found that the conditions favoured Canada, the USA and the Caribbean, see chart. The earliest signal to reach him originated from the Caribbean Beacon, Anguilla on 1610, which became audible at 0230, but it was not until 0330 that CJRS in Sherbrooke, Quebec on 1510 became audible. Others were then heard, see chart. At 0430 he logged KDKA in Pittsburgh, USA on 1020. Much to his surprise, the signals from CHAM in Hamilton, Ontario on 820 could still be heard at 0600.

### Other MW DX

Some of the sky wave signals from stations in N.Africa have been reaching the UK around dusk. Listening in Evesham, Marc Henry picked-up two of the broadcasts from Algeria, namely Ain Beida on 531 (600/300kW) and Les Trembles on 549 (600kW), both rated as 22222. A good signal from Alger, Algeria 981 (600/300kW) was also noted around dusk by Andy Cadier in Folkestone. Later, Sheila Hughes (Morden) logged Les Trembles 549 as 32332 at 2350 and Algiers on 891 (600/300kW) as 34333 at 0015. The 1200kW transmission from Sfax, Tunisia was heard at night by Simon Holland in Douglas, IOM. Up in Glasgow, Ike Odooom rated the signals from Les

Trembles 549 as SIO333 at 0448 and Algiers 891 as SIO433 at 0430.

The 20kW transmission from Riyadh, Saudi Arabia on 1422 was logged in Thumrait, Oman by Rhoderick Illman as 24342 at 1610. He also heard a broadcast from Al Khaisah, Qatar on 1233 (100kW) at 1630, which rated as 33333.

### MW Local Radio DX

The broadcasts from 'Isle of Wight Radio', the new incremental station on 1242kHz, have been attracting the attention of many DXers. During daylight their ground wave signal can be received quite well in some areas of the UK, but there is a problem with co-channel interference from Invicta Sound (Coast AM) in many places along the south coast. Late at night their sky wave signal has been reaching Scotland! John Stevens rated their signal in Largs as SIO333 at 0115. Listeners in some other areas of the UK have also been hearing their broadcasts at night, see chart.

A new incremental station to be known as 'Spectrum Radio' was due to start broadcasting in London on June 1, but the opening of the service had to be delayed because the IBA

test transmissions on 558kHz were marred by co-channel interference from an unofficial broadcast station. Writing from Battersea, Martyn Williams says, "Spectrum is aiming to serve the many foreign residents in London with music from all over the world". Surprising as it may seem, the IBA test transmission from Lots Road on 558kHz was heard in New Radnor by Simon Hamer at 1200, whilst the co-channel signal was off the air.

In his first report from Kettering, Paul Weston mentioned 'KCBC' on 1530kHz, which is the new incremental station serving Kettering and Corby. David Wratten rated their signal in Cambridge as SIO333 at 0815 and Alan Smith has informed me that their ground wave signals reach Northampton. No doubt their broadcasts will be received in other areas too, so please let me know if you hear them.

### Short Wave DX

As expected, the ionosphere has been disturbed from time to time by the effects of solar flares, but during most days good propagation conditions have existed in the high frequency

### Long Wave DX Chart

Freq kHz	Station	Location	Power (W)	DXer
153	DLF Donebach	Germany (W)	500	B,E,G,H,I,J,K,N
162	Allouis	France	2000	B,C,E*,G,H,I,J,K,N
171	Kaliningrad	USSR	1000	B,C*,E*,G,L,N
171	Moscow	USSR	500	K
177	Oranienburg	Germany (E)	750	B,C,E*,G,H,I,J,N
183	Saarouis	Germany (W)	2000	B,C,E*,G,H,I,J,K,N
189	Motala	Sweden	300	B,D,I
189	Tbilisi	USSR	500	D*
198	BBC Droitwich	UK	500	A,C,E,G,I,K,N
198	BBC Westerglen	UK	50	B,J
207	DLF Munich	Germany (W)	500	B,C,G,H,I,K,N
216	Roumoules	Monaco	1400	B,C,E,G,H,I,J,K,N
216	Oslo	Norway	200	B,D,H*
225	Konstantinow	Poland	2000	B,C,E*,G,H,I,J,K,N
234	Junglinster	Luxembourg	2000	B,C,D,E*,G,H,I,J,K,N
243	Kalundborg	Denmark	300	B,C,D,E*,G,H,I,J,K,L,N
252	Tipaza	Algeria	1500	B,C*,E*,G,H*,K*
252	Atlantic 252	S.Ireland	500	A,B,C,D,E,F,G,H,I,J,K,L,M,N,D
261	Burg (R.Volga)	Germany (E)	200	C,I*,*N
261	Moscow	USSR	2000	B,E*,G,K
270	Topolina	Czechoslovakia	1500	B,C,E*,G,H*,I,K,L*,N
279	Minsk	USSR	500	B,E*,L

Note: Entries marked \* were logged during darkness. All other entries were logged during daylight.

#### DXers:

A. Ted Agombar, Norwich.  
B. Kenneth Buck, Edinburgh.  
C. Andy Cadier, Folkestone.  
D. Scott Caldwell, Warrington.  
E. Jim Cash, Derby.  
F. Robin Clark, Plymouth.  
G. Marc Henry, Evesham.  
H. Sheila Hughes, Morden.  
I. George Millmore, Wootton, Isle of Wight.  
J. Ike Odooom, Glasgow.  
K. Fred Pallant, Storrington.  
L. Tim Shirley, Bristol.  
M. John Stevens, Largs.  
N. Phil Townsend, London.  
O. Graham Whiting, Leamington Spa.



# DEWSBURY

# ELECTRONICS

G4CLX



SEE REVIEW IN  
PRACTICAL  
WIRELESS  
AUGUST

## wavecom W 4010

professional-grade, high-performance data communications decoder/analyzer, yet easy to use and at an affordable price:

- decodes Morse code, standard baudot, bit-inversion, arq, fec, ASCII, packet radio and variable speed baudot and ASCII
- for professional users, 14 additional commercial data communications modes (on supplementary eproms) are available
- measures baud rates with high accuracy and makes synchronous and asynchronous bit analysis
- led-bar indication for tuning
- hard-and software additions and upgrade capabilities
- built in f7-b (f6) decoder
- universal microprocessor video card (24 lines x 80 characters or 18 lines x 40 characters)
- extensive rfi-filtering on all lines
- 5 int. language sets, including Cyrillic, Greek and Hebrew.
- RS-232c/v. 24 serial port, Centronics parallel port
- optimal customer's support due to in-home r + d and 1 year warranty

PRICES FROM **£975.00** inc. V.A.T.

FOR DETAILS OF THIS AND OTHER DECODERS PLEASE SEND S.A.E.

Dewsbury Electronics, 176 Lower High Street, Stourbridge, West Midlands DY8 1TG  
Telephone: Stourbridge (0384) 390063/371228  
Fax: (0384) 371228

**NOW  
AVAILABLE  
VERSION  
5**

Stockists of DAIWA – POCOM – ICOM – YAESU – TASCOS TELEREADERS – MICROWAVE MODULES



APPROVED KENWOOD DEALER.



Instant finance available subject to status. Written details on request.

# SEEN & HEARD

bands. It is still not certain that the peak of the present solar cycle has been reached.

Although the 25MHz (11m) band is in daily use by nine broadcasters, it is surprising that others have not decided to join them. The regular occupants are BRTF Brussels, Belgium 26.645; SRI via Schwarzenburg, Switzerland 25.680; RNI via Kvitsoy, Norway 25.730; Radio Denmark relayed by RNI 25.730; Radio DW via Julich, W. Germany 25.740; Radio Moscow, USSR 21.780; Radio Yugoslavia, Belgrade 25.795; RFI via Issoudun, France 25.820; BBC via Daventry, UK 25.870. They have now been rejoined by the Voice of the UAE in Abu Dhabi on 25.890. Whilst checking the band in Prenton, Kenneth Reece picked up their broadcast in Arabic at 0559, which he rated as 33433.

Reporting from Quebec, Alan Roberts says there has been a marked deterioration in the 11m propagation conditions between Europe and Canada. His daily checks proved to be very disappointing, as there was a complete absence of signals during 23 days. Although most of the broadcasts could be received during other days, there were considerable variations in signal rating. For example the BBC transmission to W. Africa via Daventry, UK 25.870 (Fr 1200-1245) varied between inaudible and a potent 45555. Particularly good propagation conditions existed during one day only - a sharp contrast to four months ago!

Although many of the 11m broadcasts can be heard in the UK, the reception of most of them is poor as they are all intended for other areas. In contrast, there are many broadcasts to Europe in the 21MHz (13m) band during the day. Those noted stemmed from Radio Japan via Moyabi, Gabon 21.690 (Russ, Sw, It, Fr 0530-0700), rated as SIO333 by

Freq kHz	Station	ILR	Power (kW)	Dxer	Freq kHz	Station	ILR	Power (kW)	Dxer
558	Spectrum Radio	1	?	D,K,U,6	1161	Viking R.(Gold)	1	0.35	B,G
585	R.Solway	B	2.00	E,J,N*,S	1170	Ocean Sound	1	0.12	Q
603	Invicta Snd(Coast)	1	0.10	D,N,P,Q,3,8	1170	R.Orwell	1	0.28	D,N,8
603	R.Gloucester	B	0.10	G,H,I,N,P,Q,X,8	1170	Signal R	1	0.20	E*,G,N
630	R.Bedfordshire	B	0.20	D,G*,J,L,N,P,Q,V*,3,5,8	1170	Swansea Sound	1	0.58	H*,L,M
630	R.Cornwall	B	2.00	B,H,L,Q	1170	TFM Radio (GNR)	1	0.32	J,S
657	R.Clwyd	B	2.00	B,E*,J,Q,S,8	1242	Invicta Snd(Coast)	1	0.32	D,M*,P,R,X,3,4,8
666	DevonAir R	1	0.34	H,N,Q,2,8	1242	Isle of Wight R	1	0.50	H,L,M*,N,O,Q,R,U*,X,Y,Z,1*,7*,8
666	R.York	B	0.80	G*,J,S,8	1251	Saxon R	1	0.76	D,F,P,S,3,8
729	BBC Essex	B	0.20	D,G*,J,Q,3,8	1260	GWR (Brunel R.)	1	1.60	H*,N,Q,8
738	Hereford/Worcester	B	0.037	G*,L,N,X,8	1260	Leicester (GEM-AM)	1	0.29	E*,G,N,5,8
756	R.Cumbria	B	1.00	J,Q,S	1260	R.York	B	0.50	J,S
756	R.Shropshire	B	0.63	G*,L,N,Q,8	1278	Pennine R.(C.Gold)	1	0.43	B,E,J
765	BBC Essex	B	0.50	A,C,D,G*,N,Q,3,5,8	1305	R.Hallam (C.Gold)	1	0.15	B,G,8
774	R.Kent	B	0.70	A,D,P,Q,3,5,8	1305	Red Dragon R	1	0.20	H,L,N,P,Q,S,8
774	R.Leeds	B	0.50	E,G,J	1323	R.Bristol	B	0.63	H,N,S,8
774	Severn Sound	1	0.14	J,L,N,8	1323	Southern Sound	1	0.50	D,P,Q,3,8
792	Chiltern R	1	0.27	D,G*,N,P,3,5,8	1332	Hereward R	1	0.60	D,3,5,8
801	R.Devon	B	2.00	G,H,I,L,N,Q,8	1332	Wiltshire Sound	B	0.30	N,Q,S
819	Hereford/Worcester	B	0.037	I,N,8	1359	Essex R.(Breeze)	1	0.28	D,P,3,8
828	2CR	1	0.27	D,H,Q	1359	Mercia Snd(Xtro-AM)	1	0.27	N,8
828	R.WM	B	0.20	E,N	1359	Red Dragon R	1	0.20	N
828	R.Aire	1	0.12	B,J	1359	R.Solent	B	0.85	H,Q,S
828	Chiltern R	1	0.20	N,P,3,5,8	1368	R.Lincolnshire	B	2.00	A,5,8
837	R.Cumbria	B	1.50	E,J	1368	R.Sussex	B	0.50	D,P,Q,S,3
837	R.Leicester	B	0.45	G,N,P,3,5,8	1368	Wiltshire Sound	B	0.10	N,P
855	R.Devon	B	1.00	H,Q	1413	Sunrise R	1	?	P,3
855	R.Lancashire	B	1.50	I,J	1431	Essex R.(Breeze)	1	0.35	D,P,S,V,3,8
855	R.Norfolk	B	1.50	A,D,J,N,P,3,8	1431	Radio 210	1	0.14	Q
873	R.Norfolk	B	0.30	D,G,J,N,P,3,5,8	1449	R.Cambridgeshire	B	0.15	A,C,5,8
936	GWR (Brunel R.)	1	0.18	J,L,N,P,Q,8	1458	R.Devon	B	2.00	H,Q
945	R.Trent (GEM-AM)	1	0.20	B,D*,G,I,N,S,5,8	1458	GLR	B	50.00	D,N*,P*,Q,5,8
954	DevonAir R	1	0.32	H,Q	1458	GMR	B	5.00	S,7
954	R.Wyvern	1	0.16	I,N,8	1458	R.Newcastle	B	2.00	J
990	R.Aberdeen	B	1.00	J	1458	Radio WM	B	5.00	G,N
990	Beacon R. (WABC)	1	0.09	N,8	1476	County Sound(Gold)	1	0.50	D,N,P,Q,8
990	R.Devon	B	1.00	H,L,P,Q,X	1485	R.Humberside	B	1.00	B,G,J,8
990	Hallam R.(C.Gold)	1	0.25	G,8	1485	R.Merseyside	B	1.20	I,S
999	Red Rose R	1	0.80	E*,J,S	1485	R.Oxford	B	0.50	N,X,8
999	R.Solent	B	1.00	D,H,N*,P,Q,8	1485	R.Sussex	B	1.00	D,P,Q
999	R.Trent (GEM-AM)	1	0.25	G,N,5,8	1503	R.Stoke-on-Trent	B	1.00	E*,G,I,N,S,8
1026	R.Cambridgeshire	B	0.50	G,N,P,V*,3,5,8	1521	R.Mercury	1	0.64	C,D,P*,Q,3,8
1026	Downtown R	1	1.70	J,N*,S	1521	R.Nottingham	B	0.50	G,S,8
1026	R.Jersey	B	1.00	D,H,L,P,Q	1530	R.Essex	B	0.15	D
1035	R.Kent	B	0.50	D,P,3,8	1530	KCBC Kettering	1	?	X,5,8
1035	NorthSound R	1	0.78	J,N*	1530	Pennine R.(C.Gold)	1	0.74	B,G,J,N*
1035	R.Sheffield	B	1.00	G	1530	R.Wyvern	1	0.52	H,N,S
1035	West Sound	1	0.32	S	1548	R.Bristol	B	5.00	H,L,N,Q
1107	R.Northampton	B	0.50	G,N,P,Q,5	1548	Capital R. (Gold)	1	97.50	D,N,P*,Q,V*,8
1116	R.Derby	B	1.20	B,G,N,W,5,8	1548	R.Cleveland	B	1.00	J
1116	R.Guernsey	B	0.50	D,H,P,Q,W,8	1548	R.Forth (Max AM)	1	2.20	S
1152	RFMB (Xtra-AM)	1	3.00	G,N	1548	R.Hallam	1	0.74	G,8
1152	R.Broadland	1	0.83	A,N,8	1557	R.Lancashire	B	0.25	N*,S,T
1152	R.Clyde (Clyde 2)	1	3.60	S	1557	Chiltern R	1	0.76	B,F,G,N,5,8
1152	LBC (L.Talkback R)	1	23.50	D,P*,Q	1557	Ocean Sound	1	0.50	H,P,Q,S*
1152	Metro R. (GNR)	1	1.80	J,W*	1584	R.Nottingham	B	1.00	G,5,8
1161	R.Bedfordshire	B	0.10	P,X,5,8	1584	R.Shropshire	B	0.50	N,S
1161	GWR (Brunel R.)	1	0.16	I,N,Q	1584	R.Tay	1	0.21	S
1161	R.Sussex	B	1.00	D,P,Q,W	1602	R.Kent	B	0.25	B,C,D,O*,P,Q*,3,8
1161	R.Tay	1	1.40	N*,S,W*					

Note: Entries marked \* were logged during darkness. All other entries were logged during daylight.

- Dxers**  
**A. Ted Agomar.** Norwich  
**B. Leo Barr.** Sunderland  
**C. Darren Beasley.** Bridgwater  
**D. Andy Cadler.** Folkestone  
**E. Scott Caldwell.** Warrington  
**F. Derek Carter.** Cambridge  
**G. Jim Cash.** Derby  
**H. Robin Clark.** Plymouth  
**I. Matthew Clarke.** On the Clent Hills  
**J. Adrian Don.** While on Pontop Pike  
**K. Simon Hamer.** New Radnor  
**L. Geoff Harris.** Sturminster Newton  
**M. Francis Hearne.** Bristol  
**N. Marc Henry.** Evesham  
**O. Simon Holland.** Douglas IOM  
**P. Sheila Hughes.** Llandudnam  
**Q. George Millmore.** Wootton Bassett  
**R. John Nash.** Brighton  
**S. Ika Odoom.** Glasgow  
**T. John Parry.** Northwich  
**U. Roy Patrick.** Derby  
**V. John Sadler.** Bishops Cleeve  
**W. Tim Shirley.** Bristol  
**X. Alan Smith.** Northampton  
**Y. Roy Spencer.** Coventry  
**Z. Cliff Stapleton.** Torquay  
**1. John Stevens.** Largs  
**2. Lucian Thomas.** London  
**3. Phil Townsend.** London  
**4. Ted Walden-Vincant.** G.Yarmouth  
**5. Paul Weston.** Kettering  
**6. Martyn Williams.** Bantersea  
**7. Harold Wood.** Manchester  
**8. David Wratten.** Cambridge



Philip Rambaut of Macclesfield.

Tim Shirley; Voice of Israel, Jerusalem 21.780 (Eng, Fr 1000-1100) 44444 at 1013 by Leo Barr in Sunderland; Radio Romania Int, Bucharest 21.665 (Eng 1300-1356) 43333 at 1300 by Chris Shorten in Norwich; Radio Kuwait, Sulaiyah 21.675 (Ar 0800-1800) SIO55555 at 1435 by Kenneth Buck; WCSN Scotts Corner, Maine 21.780 (Eng, Ger, Fr 1400-1555) 43434 at 1435 by Cliff Stapleton in Torquay; Voice of Israel, Jerusalem 21.760 (Heb 0515-1645) SIO555 at 1450 by Thomas Barnett in Slough; Radio Japan via Moyabi, Gabon 21.700 (Eng, Jap 1500-1700) SIO344 at 1500 by Brian Hallett in Burgess Hill; UAE Radio Dubai 21.605 (Ar, Eng 0600-1645) 33333 at 1600 by Derek Carter in Cambridge; Radio HCJB Quito, Ecuador 21.470 (Cz, Ger, Sw, Eng, Norw, Da, Fr 1800-2200) SIO333 at 1926 by Philip Rambaut in Macclesfield; WYFR via Okeechobee, Florida 21.615 (Eng, Ger, It 1600-2145) 55544 at 1934 by Darren Beasley in Bridgwater.

Some of the broadcasts to other areas may also be received here. They include the BBC via Hong Kong 21.715 (Eng 0100-0900), noted as 23332 at 0434 by Kenneth Reece; Radio Australia via Darwin 21.525 (Eng to C.Asia 0100-0900) 24542 at 0600 by David Edwardson in Wallsend; Radio Prague, Czechoslovakia 21.705 (Eng

to SE Asia 0730-0800) SIO333 at 0730 by Harold Wood in Manchester; Radio Australia via Carnarvon 21.775 (Eng to S.Asia 0100-1100) 43544 at 1006 by John Nash in Brighton; Radio Moscow, USSR 21.725 (Eng to Africa 0700-1600) 55555 at 1040 by Ken Whayman in Bexleyheath; Radio Finland via Pori 21.550 (Eng to USA 1300-1330) 44444 at 1300 by Sheila Hughes; SRI via Schwarzenburg 21.695 (Eng, Fr, Ger to S.Asia 1315-1500) SIO433 at 1400 by Alf Gray in Birmingham; VOA via Kavala, Greece 21.610 (Pa to Middle East 1430-1515) 44333 at 1430 by Rhoderick Ilman (Oman); WCSN Scotts Corner, Maine 21.640 (Eng, Fr to N/E Africa 1600-1955) SIO333 at 1657 by Ron Pearce in Bungay; Vatican Radio, Rome 21.650 (Fr, Eng, Port to Africa 1630-1825) 44444 at 1745 by Jim Cash in Swanwick; Radio Nederlands via Bonaire, Ned. Antilles 21.685 (Eng, Fr, Du to S.Africa 1830-2125) 55444 at 1837 by Ted Agomar in Norwich; Radio DW via Trincomalee, Sri Lanka 21.570 (Eng, Ger to SE Africa 1700-1855) 45554 at 1838 by John Parry in Norwich.

Good reception of some of Radio Australia's 17MHz (16m) broadcasts has been noted in the UK, although they are intended for other areas.



# STEPHENS-JAMES LTD.

47 WARRINGTON ROAD, LEIGH, LANCS. WN7 3EA

Telephone (0942) 676790

Turn at the Greyhound Motel on the A580 (East Lancs. Road).



**SHOP HOURS**  
**Mon - Fri 9.30-5.00pm**  
**Sat 9.30-4.30pm**  
 24 HOUR MAIL ORDER SERVICE

## ANTENNA RANGE

<b>CUSHCRAFT</b>	
A3 3 Element Tribander Beam	£329.00
A4 4 Element Tribander Beam	£353.35
10-3CD 3 Element 10m Monobander	£115.04
15-3CD 3 Element 15m Monobander	£139.70
20-3CD 3 Element 20m Monobander	£238.21
AP8 8 Band Vertical 25ft High	£164.35
AP5 5 Band Vertical 25ft High	£123.36
18 Element 2m Boomer Antenna	£106.59
15 Element 2m Boomer Antenna	£98.99
Ringo Ranger 2m Vertical	£42.98
New R5 5 Band half wave vertical	£259.00
DW 10, 18, 24 MHz Rotary dipole	£159.00
<b>BUTERNUT</b>	
HF 6VX 6 Band vertical Antenna	£167.00
HF 2V 80/40 metre Vertical	£142.00
A 1824 HF6V 17/12m Add on kit	£34.99
20MRK HF2V 20m Kit	£33.39

<b>HY-GAIN</b>	
TH2 Mk3 3 Element Tribander	£249.00
18AVT 5 Band Vertical	£146.00
<b>JAYBEAM</b>	
TB3 Mk3 3 Element Tribander	£365.00
TB2 Mk3 2 Element Tribander	£246.00
TB1 Mk3 Rotary Triband dipole	£123.30
VR3 Mk3 Triband Vertical	£85.56
DB44 & 6m Element Beam	£139.37
4Y/4m 4m 4 Element Beam	£198.46
4Y/6m 6m 4 Element Beam	£58.05
LW5/2m 5 Element 2m	£22.53
LW8/2m 5 Element 2m	£28.28
PBM14/2m Parabeam	£83.05
5XY/2m 5 Element Crossed	£42.68
8XY/2m 8 Element Crossed	£54.60
<b>HAND HELD SCANNING RECEIVERS</b>	
WIN 108 Air band	£175.00
AR100 Handheld Receiver	£249.00
AR900UK	£235.00
Base station Receiver AR2002	£487.00
NEW HF 225 general coverage receiver	£395.00
NEW "Jupiter" Multi-Channel Handheld Receiver	£299.00
"Jupiter" Base Receiver	£345.00

## KENWOOD RANGE

TS950SD HF Transceiver	£3,199.00
TS950S HF Transceiver	£2,499.00
SP950 Filtered Speaker	£87.50
TS940s HF Transceiver	£1995.00
AT940 Automatic Antenna tuner	£244.88
SP940 Speaker with filters	£87.55
TS440S HF Transceiver	£1138.81
AT440 Automatic Antenna tuner	£144.82
PS50 20 amp power supply	£222.49
TS140S HF Transceiver	£862.00
PS430 Power supply	£173.78
AT250 Automatic Antenna tuning unit	£366.00
AT230 Antenna tuning Unit	£208.67
SP230 Speaker with filters	£66.49
TL922 HF Linear amplifier	£1495.00
MC500 Base station microphone	£46.00
MC60A De Luxe desk microphone	£88.22
TR751E 2m Multimode Mobile Transceiver	£599.00
TR851E 70cm multimode transceiver	£699.00
TM231E 50watt 2m Transceiver	£289.00
TM431E 35watt 70cm Transceiver	£318.00
TM701E 25watt 2m/70cm Transceiver	£489.00
TS680S HF Transceiver + 6Metres	£995.00
TH25 2m FM Handheld Transceiver	£238.00
TH205E 2m FM Handheld Transceiver	£199.00
TH215E 2m Handheld FM Transceiver	£228.00
TH405E 70cm Handheld FM Transceiver	£245.00
R5000 General coverage receiver	£875.00
VC20 VHF Converter 108-174MHz	£167.21
R2000 General coverage receiver	£595.00
VC10 VHF Converter 118-174MHz	£161.95
H55 De Luxe headphones	£37.54
TS790E Dual Bander Transceiver	£1495.00
LF30A Low Pass Filter	£32.26
SP50 Mobile Speaker Unit	£20.40
TH75E Handheld Dual Bander	£398.00
Full range of accessories stocked microphones. SWR meter, DC Leads, Antennas etc.	
Full size G5RV Antenna £18.00. Half size £16.00. High Power 7MHz Traps £19.50. Dipole Kits £25.00. 3.7MHz traps £12.00. 200 watt. 8MHz traps £12.00.	
AOR950 Base Station Receiver	£249.00

## TEN-TEC

We are pleased to announce we are now the official North West Stockist for the full range of the TEN-TEC range of HF equipment.

"Paragon" HF Transceiver with full general coverage receiver facilities. **£1839.00**  
 "Corsair" MkII HF Amateur Band Transceiver **£1200.00**  
 New Amateur Band only Transceiver "Omni V" **£1900.00**

FULL RANGE OF ACCESSORIES AVAILABLE SEND S.A.E. FOR DETAILS

## MFJ ACCESSORIES RANGE

MFJ 1601 Random Wire Tuner	£45.00
MFJ 1701 6 way Antenna switch	£39.50
MFJ 949C Versatuner	£168.00
MFJ 941D Versatuner	£125.00
MFJ 901B Versatuner	£65.00
MFJ 300 watt dummy load	£33.50
MFJ RF Noise Bridge	£63.10
MFJ-931 Artificial Ground	£79.53
MFJ-962B 1kW Antenna Tuner	£291.95

<b>ROTATORS</b>	
G400RC	£169.00
G6600RC	£219.00
T2 X Heavy duty rotator	£399.00
CDE AR40	£168.72
CD 451 1R	£237.00
EMOTATOR 1057SY	£159.00

<b>POWER SUPPLIES</b>	
PS30M Heavy duty 30A, 22A cont	£129.50
PS120M 3-15V variable 12A max	£79.50

Postage/ carriage at cost. We are also stockist for Global, Datong, and have a full range of publications by RSGB-ARRL and others. Our secondhand list is updated daily. Please send SAE for this or any information.

## YAESU

# Reg Ward & Co. Ltd.

1 Western Parade, West Street, Axminster, Devon EX13 5NY  
 Tel: (0297) 34918

## KENWOOD

**YAESU FRG 8800** **£649.00**  
  
 Super HF/VHF receiver (VHF option) LCD direct readout with 8-bit CPU function control. 21 button keypad entry or V.F.O. frequency selection. Full general coverage 150kHz-29.999MHz AM/FM/LSB/USB/CW. 12 memories with back up. 100/120/220/240V plus 12V d.c. operation (optional). Clock and timer on/off control - socket. FRV8800 VHF CONVERTIBLE £1000.00 (1180174MHz direct read out - plug in) FRVWFM £49.00 (wide band FM unit)

**FRT7700 Receive ATU 150kHz-30MHz** **£59.00**  
 carriage £3.50

**YAESU FRG9600** **£499.00 (60-905MHz)**  
**FRG9600M 60-950MHz** **£509.00**

  
 All mode scanning receiver covering 60-905MHz (60-905 9600M) continuously with 100 keypad programmable memory channels. Full, limited or memory scanning.  
 Optional accessories D130 Discone antenna £75.00 carr. £4.00 PA4C power supply £25.00 carr. £2.50. FC965 DX Ext converter £89.00 carr. £3.00. FC1300 Ext converter **£119.00** carr. £3.00.

## HANDY SCANNERS!

<b>HX850E REGENCY</b> new low price <b>£179.00</b> carriage £4.00
20 Channel memory AM/FM selectable scanner 60-89MHz, 118-136MHz, 140-174MHz, 406-495MHz.
<b>AR800 VHF/UHF</b> <b>£169.00</b> carriage £4.00
Handheld scanner 75-105, 118-174 406-495 830-950MHz
<b>AR900 VHF/UHF Handheld</b> 108-174, 220-280 300-380, 401-470, 830-950MHz <b>£199.00</b> carriage £4.00
<b>AR1000 VHF/UHF</b> <b>£249.00</b> carriage £4.00
8-1300MHz 1000 memories.
<b>JUPITER II Handheld</b> 25-550MHz 800-1300MHz <b>£275.00</b> carriage £4.00
<b>BEARCAT UBC 200XL</b> <b>£229.00</b> carriage £4.00
66-88 136-174 406-512 806-956MHz.

## ICOM

<b>IC-R71E HF Receiver</b> <b>£855.00</b>
100kHz-30MHz CW/SSB/AM/RTTY/FM (optional). Direct frequency entry. 32 memories. Scanning. Remote control and 12 volt d.c. option.
<b>IC-R7000VHF/UHF</b> <b>£989.00</b>
Continuous coverage receiver. 25MHz-2000MHz FM/AM/SSB modes direct frequency entry. 99 memories. Scanning. remote control option.

## NEW

<b>R100 Mobile/Base Scanner</b> 500kHz-1800MHz <b>£499.00</b> carriage £4.00
<b>R1 Handheld scanner</b> 150kHz-1300MHz <b>£399.00</b> carriage £4.00
<b>R72 HF Receiver</b> 100kHz-30MHz <b>£645.00</b>

## SONY

<b>ICFPRO80</b> <b>£299.00</b>
✓ Super-wide coverage (PRO80) - 150kHz. 108MHz plus 115.15MHz 223MHz. PRO70 - 150kHz -108MHz **
✓ Pro-feel 8 way tuning system
✓ 40-station random preset memory
✓ 2-position AM selectivity SSB and narrow FM reception
✓ Squelch controller (auto & manual)
<b>ICF 20010</b> <b>£299.00</b>
Super-wide coverage (150-29999 9kHz 76-108MHz, 116-136MHz) with the versatility of both digital and "precise-feel" analog tuning. There's also two types of scan modes, either auto-stop or 1.5 second hold, 2-position AM selectivity, AM RF-gain control, AM attenuator, 3-position tone control, direct meter band access, 4-event programmable time and SSB* reception. Plus an external antenna for AM, FM and AIR Band. In short, everything an enthusiast could ever want in a high-performance receiver - and can only get from Sony!

<b>AIR7</b> <b>£229.00</b>
✓ AIR band/FM/AM reception
✓ Compact, hand-held design
✓ Quartz PLL-synthesizer digital tuning
✓ Microprocessor control of direct, scan, present tuning, plus the program, priority and delayed scan functions for AIR band
✓ 30 - station preset memory (10 per band)
✓ Front-panel oval speaker
✓ Rubber-booted helical antenna
✓ Carrying belt and earphone.

## KENWOOD R5000

**£875.00**  
  
 The frequency range is continuous from 100kHz to 30MHz and its modes of operation are USB, LSB, CW, AM. FM and FSK. An optional VHF converter (VC20), extends the frequency range to include 108 to 174MHz.

**R2000** **£595.00**  
 This is an innovative all-mode SSB, CW, AM, FM receiver that covers 150kHz-30MHz. With an optional VC-10VHF converter unit, coverage of the 118-174MHz frequency range is possible. New microprocessor controlled operating features and an "UP" conversion PLL circuit assure maximum flexibility and ease of operation.

**LOWE HF-225** **£425.00**  
  
 carriage £5.00 Coverage is continuous from 30kHz to 30MHz and operating modes are AM, USB, LSB and CW with an optional FM and synchronous AM board. A comprehensive range of bandwidth filters are standard. 2.5, 4, 7 or 10kHz.

## BASE/MOBILE SCANNERS

<b>JUPITER BASE STATION MVT6000</b> 25-550MHz 800-1300MHz 12VDC or 24VAC 100 memories 5, 10, 12.5, 25 or 30kHz steps. <b>£345.00</b> carriage £5.00
<b>KENWOOD R21</b> 100kHz-955MHz <b>£465.00</b> carriage £4.00
<b>AOR AR2002</b> 26-550-800-1300MHz 12VDC or 240VAC <b>£487.00</b>
<b>AOR AR3000</b> 100kHz-2036MHz <b>£765.00</b> carriage £8.00

## ANTENNAE!

<b>DATONG AO370</b> HF O/Door Act. Ant <b>£77.62</b> carriage £4.00
<b>DATONG AO270</b> HF Indoor Act. Ant <b>£58.22</b> carriage £3.00
<b>O 130-26</b> 1300kHz <b>£75.00</b> carriage £4.00
<b>OSC 770</b> 70-700MHz <b>£24.95</b> carriage £4.00

OPEN TUES.-SAT. 9.00-5.30 (CLOSED MONDAYS)  
 LUNCH 1.00-2.00

STOCK ITEMS USUALLY DESPATCHED WITHIN 48 HOURS

Instant credit available. Mail/Telephone order by cheque or credit card. Cheques cleared before goods despatched.

# SEEN & HEARD

## Medium Wave DX Chart

Freq kHz	Station	Country	Power (kW)	DXer	Freq kHz	Station	Country	Power (kW)	DXer
520	Wurzberg	Germany (W)	0.2	P*	945	Toulouse	France	300	K*
531	Ain Beida	Algeria	600	K*	954	RCE Madrid	Spain	20	K*
531	Leipzig	Germany (E)	100	O	963	Porto	Finland	600	K*,L*
531	Oviedo	Spain	10	E*,K*,P*	963	RRE Seixal	Portugal	10	E*
540	BRT-2 Wavre	Belgium	150/50	F,K,O,U	972	NDR/WDR Hamburg	Germany (W)	300	K*
549	Les Trembles	Algeria	600	K*,M*,P*	981	Alger	Algeria	600/300	D*,K*
549	DLF Bayreuth	Germany (W)	200	K,O,U	990	SER R.Bilbao	Spain	10	K*
558	Espoo	Finland	100	O,R*	990	BBC-Redmoss	UK	1	P
558	Valencia	Spain	20	K*,P*	999	R Popular, Madrid	Spain	20	K*,M*
567	West Berlin	Germany (W)	100	K*	1008	Hilversum-5 Flevo	Holland	400	M*,O,U
567	RTE-1 Tullamore	S.Ireland	500	F,H,J,K,M*, O,P*,U	1017	SWF Wolfshelm	Germany (W)	600	M*,V*
576	Stuttgart	Germany (W)	300	J,O	1035	Prog.3 Lisbon	Portugal	120	E*,K*
576	Riga	USSR	500	P*	1044	DDR-1 Burg	Germany (E)	250	C*,K*
585	FIP Paris	France	8	K*,O,R	1053	BBC-R1 Stagshaw	UK	50	I
585	RNE-1 Madrid	Spain	200	K*,M*,P*	1062	Kalundborg	Denmark	250	C*,P*
594	HRF Frankfurt	Germany (W)	400	K*,P*	1071	Brest	France	20	O
603	Sevilla	Spain	20	P*	1089	BBC-R1 Moorside Edge	UK	150	I,O
603	BBC-R4 Newcastle	UK	2	I	1089	BBC-R1 Washford	UK	50	K
612	RTE-2 Athlone	S.Ireland	100	F,J,K,M,P	1107	BBC-R1 Wallasey	UK	0.5	B,I
621	RTBF-1 Wavre	Belgium	300	E*,J,K,M,O,U	1125	La Louviere	Belgium	20	O
621	Barcelona	Spain	10	P*	1125	BBC Landrindod Wells	UK	1	K
630	Vigra	Norway	100	P*	1134	Valencia	Spain	10	K*
639	La Coruna	Spain	100	K*,M*,P*	1143	Century R. Dublin	Ireland (S)	?	E,K,L*
648	Palma de Mallorca	Spain	10	E*,P*	1143	Kaininograd	USSR	150	K*
648	BBC Orfordness	UK	500	L,J,K,M*,D	1179	Solvesborg	Sweden	600	K*,M*
657	Burg	Germany (E)	250	K*	1188	Kuurne	Belgium	5	K*,O
657	RCE-2 Madrid	Spain	20	E*,K*	1197	VOA via Munich	Germany (W)	300	K*
657	BBC-R.Wales Wrexham	UK	2	H,K	1197	BBC-R3 Bournemouth	UK	0.5	O
666	Bodenseesender	Germany (W)	300/180	E*,P*	1206	Bordeaux	France	100	C*
675	Marseille	France	600	M*,P*	1206	Wroclaw	Poland	200	E*,K*
675	Hilversum-3 Lopic	Holland	120	F*,K,M*,O,U	1215	BBC-R3 Moorside Edge	UK	100	A,O
684	RNE-1 Sevilla	Spain	250	M*,P*	1215	BBC-R3 Newcastle	UK	2	I
684	Beograd	Yugoslavia	2000	R*	1233	Prague	Czechoslovakia	400	C*
693	BBC-R2 Stagshaw	UK	50	I	1233	AI Khatisah	Qatar	100	N
702	Zamora	Spain	5	P*	1242	Marseille	France	150	S*
711	RF Armorique	France	?	U	1251	Huisborg	Netherlands	10	C*,K*
711	Rennes 1	France	300	F,O,V*	1269	Neuminster	Germany (W)	600	A,K*,V*
711	Heidelberg	Germany (W)	5	P*	1278	RTE-2 Dublin/Cork	Ireland (S)	10	G,K
720	BBC-R4 Lisnagarvey	N.Ireland	10	I,K	1296	BBC Orfordness	UK	500	K*,L*,U
720	Norte	Portugal	100	P*	1296	Baku	USSR	150	R*
720	BBC-R4 Lots Rd London	UK	0.5	F*,O	1314	Kvitsoy	Norway	1200	C*,F*,K*,P*,U
729	RTE-1 Cork	S.Ireland	10	G,K*	1323	R.Moscow via Leipzig	Germany (E)	150	K*,V*
729	Oviedo	Spain	50	P*	1332	Rome	Italy	300	C*
738	Paris	France	4	O	1341	BBC-Ulster Lisnagarvey	N.Ireland	100	F*,J,K*
738	RNE-1 Barcelona	Spain	250	K*,M*,P*	1350	Nancy/Nice	France	100	K*,P*,V*
747	Hilversum-2 Flevo	Holland	400	K*,M*,P*,U	1359	RBI Berlin	Germany (E)	250/100	K*
756	Brunswick	Germany (W)	800/200	M*,P*	1368	Manx Radio, Foxdale	I.O.M	20	B,C*,F*
765	Sottens	Switzerland	500	M*,P*	1377	Lille	France	300	K*,O,U
774	RNE-1 San Sebastian	Spain	60	P*	1386	Kaunas	USSR	1000	C*,E*,F*,K*,M*
783	Burg	Germany (E)	1000	K*,O,P*	1395	R.Tirana via Lushnja	Albania	1000	M*,V*
792	Limoges	France	300	K*	1404	Brest	France	20	J,L*,O,V*
792	Sevilla	Spain	20	K*,P*	1413	RCE Zaragoza	Spain	20	K*
801	BRF via Munich	Germany (W)	420	P*	1422	Heusweiler	Germany (W)	600	K*,M*,V*
801	Castellon	Spain	5	P*	1422	Riyadh	Saudi Arabia	20	N
810	SER Madrid	Spain	20	K*,P*	1431	Dresden	Germany (E)	250	K*,R*
810	BBC-Scot Westerglen	UK	100	L,K*	1440	Marrach	Luxembourg	1200	F,G,J*,K*,O,V*
819	Sud-Radio	Andorra	900	L*	1449	BBC-R4 Redmoss	UK	2	B,I
819	Toulouse	France	50	P*	1467	TWR Monte Carlo	Monacco	1000/400	K*,L*,M*,P*,V*
837	Nancy	France	200	K*,O	1485	BBC-R4 Carlisle	UK	1	I
846	Rome	Italy	540	F*	1494	Leningrad	USSR	1000	F*,K*
855	RAIS Berlin	Germany (W)	100	K*	1503	Stargard	Poland	300	M*
855	Murcia	Spain	125	P*	1512	BRT Wolvortem	Belgium	600	F*,J,K*,L*,M,O,V*
864	Paris	France	300	K*,O,U,V*	1521	Oviedo	Spain	5	K*
873	AFN Frankfurt	Germany (W)	150	F*,K*,P	1530	Vatican Radio, Rome	Italy	150/450	B,F*,J*,K*,M*,O*,S*
882	BBC-Wales Washford	UK	70	F,G,H,I,K,O,U	1539	DLF Mainflingen	Germany (W)	700	F*,K*
891	Algiers	Algeria	600/300	M*,P*	1557	Nice	France	300	E*
900	Milan	Italy	600	P*	1566	Sfax	Tunisia	1200	L*
909	BBC-R2 Clevedon	UK	50	K	1575	RBI via Burg	Germany (E)	250	K*,L*
909	BBC-R2 Moorside Edge	UK	200	I,O	1575	Genoa	Italy	50	E*
927	BRT-1 Wolvortem	Belgium	300	F*,K,O,U	1584	Pamplona	Spain	2	E*
936	Radio Bremen	Germany (W)	100	K*	1593	Langenberg	Germany (W)	400/800	F*,J*,K*,L*,V*
936	Lerida	Spain	2	O*	1602	R.Onteniente	Spain	2	K*
936	Lvov	USSR	500	E*	1611	Vatican Radio, Rome	Italy	5	L*,T*

### DXers:

- A. Ted Agombar, Norwich.
- B. Leo Barr, Sunderland.
- C. Darren Beasley, Bridgewater.
- D. Andy Cadier, Folkestone.
- E. Scott Caldwell, Warrington.
- F. Jim Cash, Swanwick.
- G. Robin Clark, Plymouth.
- H. Matthew Clarke, on the Clint Hills.
- I. Adrian Don, Porton Pike.
- J. Geoff Harris, Sturminster Newton.
- K. Marc Henry, Evesham.
- L. Simon Holland, Douglas, IOM.
- M. Sheila Hughes, Morden.
- N. Rhoderick Illman, Thurmount, Oman.
- O. George Millmore, Wootton 10W.
- P. Ike Odoom, Glasgow.
- Q. Roy Patrick, Derby.
- R. Tim Shirley, Bristol.
- S. Alan Smith, Northampton.
- T. John Stevens, Largs.
- U. Phil Townsend, London.
- V. Paul Weston, Kettering.

but few were noted: Radio Sophia, Bulgaria 17.825 (Ger, Fr, Eng 0530-0700), rated 54444 at 0643 by Andy Cadier; Radio Pakistan, Islamabad 17.555 (Ur, Eng 0715-1120) 43333 at 1118 by Alan Smith; Radio Suriname Int., via RNB Brasilia, Brazil 17.755 (Du, Eng 1700-1745) 43543 at 1733 by John Nash; Voice of Israel, Jerusalem 17.590 (Fr, Eng 2030-1955) SIO555 at 1900 by Neil Wheatley in Newcastle-upon-Tyne; Radio HCJB Quito, Ecuador 17.790 (Eng to Europe 1900-2000) SIO243 at 1920 by Kenneth Buck; RCI via Sackville, E.Canada 17.875 (Fr, Eng 2030-2200) 32323 at 2120 by Robin Clark in Plymouth; VOFTaiwan via Okeechobee, Florida 17.750 (Eng 2200-2300) 44434 at 2200 by Sheila Hughes.

Good long distance reception has also been noted in the 15MHz (19m) band. Some of Radio Australia's broadcasts via Shepparton have reached our shores, namely 15.560 (Eng to C.Pacific 0030-0600), rated as SIO433 at 0525 by Philip Rambaut; 15.320 (Eng, Fr to C.Pacific 0200-0800) 44444 at 0525 by Bill Griffith; 15.160 (Eng, Fr to C.Pacific, W.USA 0030-0830), heard at 0600 by Tim Shirley; 15.465 (Eng to SE Asia 2100-0730), heard at 0650 by Donald Blashill in Cheltenham; 15.240 (Eng to S.Pacific 2200-0830) 45344 at 0830 by Darren Beasley.

Quite a number of the broadcasts to other distant places were logged: Radio Romania Int., Bucharest 15.340 (Eng to Africa 0530-0600), noted as 53444 at 0549 by Jim Cash; BBC via Hong Kong 15.280 (Eng, Chino to C.Asia 0100-1100) 23433 at 0608 by Kenneth Reece; TWR Agana, Guam 15.200 (Eng to E.Asia 0800-0927) 23332 at 0858 by Rhoderick Illman (Oman); RTL Luxembourg 15.350 (Fr to USA, 24hr) 45444 at 0900 by Roy Patrick in Derby; VOA via Greenville, USA 15.120 (Eng to C.America 1000-1200) 32232 at 1055 by Alan Smith; Voice of Greece, Athens 15.630 (Gr, Eng to USA 1500-1550) 44444 at 1530 by Sheila Hughes; UAE Radio Dubai 15.320 (Ar, Eng to N.Africa, Middle East 0600-2050) SIO433 at 1610 by Brian Hallett; BBC via Ascension Island 15.400 (Eng to Africa 1500-2300) SIO343 at 1615 by Neil Wheatley; Radio RSA Johannesburg, S.Africa 15.365 (Fr to W.Africa 1800-2000) 54444 at 1805 by Chris Shorten; Radio Netherlands via Talata Volon, Madagascar 15.560 (Eng to S/C.Africa 1830-1925) 53433 at 1830 by John Sadler; RFI via Issoudun, France 15.300 (Fr to W.Africa 0700-2100) 55555 at 1832 by Ike Odoom; Africa No.1., Gabon 15.475 (Fr, Eng to W.Africa 1600-2110) 45554 at 1910 by John Parry; Radio Damascus, Syria 15.095 (Eng to USA 2110-2210) 34343 at 2135 by Cliff Stapleton; VOA via Greenville, USA 15.580 (Eng to W.Africa 1600-2200) 33334 at 2158 by Roy Spencer.

Also noted, were some of the broadcasts to Europe: Radio HCJB Quito, Ecuador 15.270 (Cz, Sw, Norw, Da, Ger, Eng 0500-0830), rated as 54444 at 0745 by Ted Agombar; Radio Sophia, Bulgaria 15.330 (Eng, It, Ger, Fr 1830-0025) SIO433 at 1530 by Alf Gray; UAE Radio Dubai 15.435 (Ar, Eng 0600-2050) SIO433 at 1630 by Kenneth Buck; Radio Pakistan, Islamabad 15.605 (Ur, Eng 1645-1900) 53534 at 1730 by John Nash; VOA via

Most stem from their Shepparton station in SE Australia: 17.630 (Chin, Eng to C/E Asia 2130-0000), noted as SIO322 at 2130 by Philip Rambaut; 17.715 (Eng to SE Asia 2200-0000) 43444 at 2200 by Roy Spencer in Coventry; 17.795 (Eng, Fr to C.Pacific areas 2100-0830) 44423 at 2245 by Lucian Thomas in London, also 43444 at 0530 by Bill Griffith in London. Their station in Darwin, N.Australia radiates their programme to E/C.Asia on 17.750 (Eng, Chin. 2300-0600), which Robin Harvey (Bourne) rated as 54434 at 2300.

The early morning transmission from Radio New Zealand Int. on 17.680 is still being marred by a plain carrier radiated by Radio Moscow between 0505 and 0550. Whilst monitoring this frequency on a daily basis at 0500, Kenneth Reece noted variations in the RNZI signal ranging from 33333

to inaudible. Later, he found that reception often improved and one morning their signal peaked to a remarkable 54434 at 0712. RNZI now advise listeners to re-tune to 9.855MHz at 0800UTC, see later. John Stevens has been trying to hear the RNZI transmission in English to Pacific areas on 17.680 at 1800, but usually it is inaudible owing to a co-channel transmission from Radio Moscow (Ar, Sp to N.Africa 1800-2030).

A number of broadcasts intended for listeners outside Europe were noted in the logs: Radio Japan, Yamata 17.810 (Eng, Jap to SE Asia 0700-0900) noted as 23432 at 0744 by David Edwardson; SRI via Schwarzenburg 17.670 (Eng to SE Asia 1000-1030) 53543 at 1000 by Ken Whayman; AIR via Delhi, India 17.387 (Eng to E.Asia 1000-1100) 45333 at

1059 by Darren Beasley; WSHB Cypress Creek, USA (Eng to W.USA 1400-1555) 43333 at 1420 by Chris Shorten; BBC via Limassol, Cyprus 17.740 (So to E.Africa 1430-1500) 42432 at 1430 by Rhoderick Illman; Radio Romania Int., Bucharest 17.720 (Eng to S.Asia, Middle East 1500-1526) 32322 at 1500 by John Sadler in Bishops Cleeve; Radio RSA Johannesburg, S.Africa 17.835 (Eng to Africa 1500-1600) 33433 at 1506 by Darran Taplin in Brenchley; RTM Tanger, Morocco 17.595 (Eng, Fr to N.Africa 1400-1700) SIO433 at 1515 by Thomas Barnett; VOA via Greenville, USA 17.785 (Eng to W.Africa 1600-2200) SIO344 at 2035 by Brian Hallett; RCI via Sackville, Canada 17.820 (Eng to Africa 2130-2159) 54545 at 2140 by Cliff Stapleton.

Many of the 16m broadcasts are beamed to Europe during the day,



**G2VF LOOP ANTENNAS WITH ATU FOR HF HAM BAND TRANSMISSION** (SWR One to One 40, 15 and 10 One Point Five to One 80 and 20) **AND SWLs LONG AND MEDIUM WAVE FOR BCLs.** Loops 21 inches square or triangle. No special skills required. Circuits, Parts Lists sources of supply assembly data. HIGH FREQUENCY LOOP 80 to 10Metres £5. LONG AND MEDIUM WAVE LOOP FOR BCLs £3. LONG MEDIUM SHORT WAVE LOOP 1500 to 10 METRES FOR BCL SWL £8. SHORT WAVE ATU LOOP OR LONG WIRE £4. PRE AMP LW MW S WAVE £2. PHOTO COPY HRO MANUAL £4. MW LOOP WITH PRE AMP ATU £3. PRE AMP FOR G2VF HF LOOP OR ATU £4. SHORT WAVE ATU BUILT-IN PRE AMP FOR LOOP OR LONG WIRE £7. SAE details. All projects D.I.Y. METAL DETECTOR £2 F. G. Rylands, 39 Parkside Avenue, Millbrook, Southampton SO1 9AF. Tel: (0703) 775064.

**THE KITS WITH ALL THE BITS!** 

**A 3-BAND RECEIVER KIT FOR £66.50!**

★ Complete in Every Detail!  
★ 80-40-20m Bands!  
★ Direct Conversion!  
★ Fully Detailed Manual!



Other super kits include:  
DTR3 TRANSCEIVER, ATUs, AUDIO FILTER etc etc ... all 'well styled' and complete!

*For full details of the 'CARLTON' and the rest of our range, send a SAE to:*

**LAKE ELECTRONICS, 7 MIDDLETON CLOSE, NUTHALL, NOTTINGHAM NG16 1BX**  
or ring Alan G4DVV on (0602) 382509 (callers by appointment only).

**ALL VALVES & TRANSISTORS**

Call or phone for a most courteous quotation  
**081-743 0899**

We are one of the largest stockists of valves etc, in the U.K.

**COLOMOR ELECTRONICS LTD.** 170 GOLDHAWK ROAD LONDON W12 8HJ

**LINK ELECTRONICS**  
THE MAJOR RETAILER OF  
**REALISTIC SCANNERS**  
**NEW SCANNERS!**

**PRO 2006:** NEW THIS MONTH  
★ PHONE FOR DETAILS! £349.95 ★

---

**PRO 2005:** AM/FM 25-520, 760-1300MHz  
400 Memories 240VAC/12VDC  
★ ONLY! £285 while stocks last! ★

---

**PRO 2022:** 68-88, 108-136 (AM), 136-174  
380-512, 806-960 MHz 200 Memories 240VAC/12VDC  
★ ONLY! £199.95 ★ List price £239.95 ★

---

**PRO 2024:** 68-88, 108-136 (AM), 136-174  
380-512MHz, 60 Memories 240VAC (12VDC on request)  
★ ONLY! £149.95 ★ List price £179.95 ★

---



**PRO 2025:** NEW THIS MONTH  
★ PHONE FOR DETAILS! £99.95 ★

---

**PRO 34 Handheld:** 68-88, 108-136 (AM), 136-174  
380-512, 806-960MHz 200 Memories  
★ ONLY! £199.95 ★ List price £249.95 ★

All Scanners Include FREE P&P 12 months warranty

**Link Electronics**  
(Authorised Tandy Dealer)  
228 Lincoln Road,  
Peterborough PE1 2NE  
(0733-45731) SAE for leaflet

**ALYNTRONICS**  
129 CHILLINGHAM ROAD, HEATON,  
NEWCASTLE-UPON-TYNE NE6 5XL TEL: 091-2761002

THE ONLY AUTHORISED DEALER IN THE NORTH-EAST FOR

**ICOM & YAESU**

WE ALSO STOCK MANY OTHER ITEMS OF EQUIPMENT FROM

MFJ ★ BUTTERNUT ★ CUSHCRAFT TONNA ★ DIAMOND ★ AOR  
BEARCAT ★ FAIRMATE ★ JUPITER ★ LOWE ★ TEAM  
MIDLAND ★ NEVADA ★ CTE ★ WELZ  
★ REVEX ★ BOOKS & MAPS ★



LICENSED CREDIT BROKER

OPEN 10am - 5.45pm TUES - FRI 10am - 4.45pm SAT

**S.E.M.** UNIT C, UNION MILLS, ISLE OF MAN  
Tel. Marown (0624) 851277

**QRM ELIMINATOR**  
A unique design, which has revolutionised interference suppression. Connects in your aerial lead and phases out interference before it gets to your receiver. Any sort of QRM, it can be next to your RX (your computer?) or several miles away, e.g. power lines, 1.5-30MHz. **£79.50.** Ex-stock.

**S.E.M. VHF CONVERTER**  
Plugs into any h.f. receiver aerial socket to give you coverage from 118 to 146MHz. Tune your receiver from 2 to 30MHz. **£65.00.** Ex-Stock.

**S.E.M. HF CONVERTER**  
Plugs into your v.h.f. scanner aerial socket and converts its range to cover 100kHz to 60MHz. Gives you full i.f., m.f., h.f., v.h.f., u.h.f. coverage. **£55.00.**

**VERY WIDE BAND PRE-AMPS.**  
3MHz to 500MHz, 9dB gain, 1.5dB N.F. and unprecedented performance. Basic Pre-Amp **£37.00.** Switched through when OFF **£42** from stock.

**AUDIO MULTIFILTER**  
Gives variable selectivity 3kHz-20Hz, passband tuning, Hi or Lo pass filters and 2 notch filters. They say this is the best filter anywhere. **£75** from stock.

If you require more information on our products, ring or write.  
Prices include VAT and delivery.  
C.W.O. or CREDIT CARD by phone.



Short Wave Receivers & Scanners

Aerial Accessories & Masts

**ELLIOTT ELECTRONICS**  
for the Radio Enthusiast



Instant finance available  
Written details on request.





RIGS, ANTENNAS, SWR BRIDGES,  
POWER SUPPLIES, TEST GEAR,  
COMPONENTS, MORSE KEYS,  
COAXIAL CABLES, ROTATORS,  
MICS, PLUGS AND SOCKETS,  
SWITCHES.



**Books for radio amateurs**  
FAMOUS "Complete Guide to VHF/UHF Frequencies 26-2250MHz"

**JAYBEAM AMATEUR ANTENNAS**  
APPOINTED DISTRIBUTOR



QSY  
OLD  
MAN TO

Call us on LEIC. 553293  
OR COME AND LOOK AROUND  
AT  
**26/28 Braunstone Gate, Leicester.**

# SEEN & HEARD

Tanger, Morocco 15.205 (Eng 1700-2200) 54455 at 1741 by Robin Clark; Voice of Israel, Jerusalem 15.640 (Yu, Heb, Eng, Fr 1645-1955) 55444 at 1900 by Ken Whayman; Voice of Vietnam, Hanoi 15.010 (Eng, Russ, Viet, Sp 1600-2130), heard at 1600 by Julian Wood in Elgin; RCI via Sackville, E. Canada 15.325 (Eng 2100-2159) 55544 at 2132 by Andy Cadier; Radio Korea, Seoul 15.575 (Ar, It, Eng, Sp, Port, Ger 1645-2300) 32222 at 2119 by Robin Harvey; WWCR Nashville, USA 15.690 (Eng 1200-0100)

33333 at 1630 by Derek Carter. Another broadcaster is now taking advantage of the good conditions in the 13MHz (22m) band, namely Radio Baghdad, Iraq. Alf Gray rated their transmission on 13.660 (Eng 2000-2115?) as SIO444 at 2105. Particularly good reception of the broadcasts from Radio Australia via Carnarvon on 13.745 (Eng to S Asia 1430-1700) has been noted in the UK. The SIO444 noted by Simon Hamer at 1600 is a typical rating. Their broadcast to C. Pacific

areas via Shepparton 13.700 (Eng 0600-0830) was logged as SIO422 at 0640 by Brian Hallett.

Some of the many other 22m broadcasts stem from Radio Jordan, Amman 13.655 (Eng to Europe 0530-1315), rated as SIO434 at 1200 by Harold Wood; BBC via Rampisham, UK 13.660 (Ar to N. Africa 1250-2000) SIO333 at 1316 by Philip Rambaut; Radio Pyongyang, N. Korea 13.650 (Sp, Eng, Fr to E. Asia, USA 1200-1350) 34222 at 1348 by Rhoderick Ilman (Oman); Radio Austria Int., Vienna 13.730 (Ger, Fr, Eng, Sp to Europe 0400-1700) 54444 at 1430 by Sheila Hughes; Radio Pakistan, Islamabad 13.665 (Ur, Eng to N. Africa, Middle East 1315-1630) SIO333 at 1601 by Kenneth Buck; AWR Agat, Guam 13.720 (Hi, Tel to S. Asia 1600-1700) 34433 at 1658 by Darran Taplin; Radio Kuwait, Sulaiyah 13.610 (Eng, Ar to Europe, USA 1800-2100) 43434 at 1835 by Cliff Stapleton; Radio DW via Julich, W. Germany 13.790 (Ha, Eng to Africa 1800-1950) 2121 at 1904 by Robin Harvey; RCI via Sackville, Canada 13.670 (Eng, Fr to Africa 1800-2000) 33333 at 1929 by Darren Beasley; WSHB Cypress Creek, USA 13.770 (Eng, Ger, Fr to E. USA, Europe 2000-2155) 55444 at 2015 by Chris Shorten; RFI Berlin, GDR 13.760 (Eng, Ger to W. USA 2145-2300) 43444 at 2154 by Roy Spencer; WHRI Noblesville, USA 13.760 (Eng, Sp, Port, Yu to E. USA, Europe 1700-0000) 33333 at 2255 by Lucian Thomas; Voice of the UAE in Abu Dhabi 13.605 (Eng to N. Africa, S. Europe 2200-0000) 33453 at 2310 by David Edwardson; WRNO New Orleans, USA 13.720 (Eng to E. USA, Europe 2100-0000) 45545 at 2356 by Robin Clark.

## Transatlantic DX Chart

USA				
880	WCBS	New York, NY	0230	B
890	WLS	Chicago, IL	0620	B
1010	WINS	New York, NY	0210	B
1020	KDKA	Pittsburg, PA	0430	A
1090	WBAL	Baltimore, MD	0250	B
Canada				
550	CFNB	Fredericton, NB	0400	A
580	CFRA	Ottawa, ON	0245	B
590	VOCM	St John's, NF	0150	B
820	CHAM	Hamilton, ON	0600	A
930	CJYQ	St John's, NF	0100	B
1200	CFGO	Ottawa, ON	0020	B
1290	CHRM	Matane, PQ	0430	A
1510	CJRS	Sherbrooke, PQ	0330	A
1570	CKLM	Laval, PQ	0030	B
1600	CHNR	Simcoe, ON	0600	B
C America & Caribbean				
640	RFQ	Guadeloupe	0550	B
1570	Atlantic Beacon	Turks & Caicos IIs	0140	A, B
1580	VOA	Antigua	0005	A, B
1610	Caribbean Beacon	The Valley Anguilla	0230	A

**DXers:**  
A: Tim Shirley, Bristol.  
B: Jim Willett, Grimsby.

There are many broadcasts to Europe in the 11MHz (25m) band. Those noted stemmed from Radio HCJB Quito, Ecuador 11.835 (Eng 0700-0830), rated as SIO444 at 0720 by Brian Hallett; SRI via Beromunster, Switzerland 12.030 (Fr, Ger, It, Eng 1000-1230) 54544 at 1211 by Roy Spencer; Voice of Mediterranean, Malta 11.925 (Eng 1400-1500) 53543 at 1400 by John Nash; Radio Pakistan, Islamabad 11.570 (Eng 1720-1800) 44444 at 1738 by Darran Taplin; AIR via Aligarh, India 11.620 (Eng, Hi 1845-2045) 43333 at 1937 by Alan Smith; Radio Portugal, Lisbon 11.740 (Eng, Fr, It 1900-2030) 45333 at 1900 by Roy Patrick; RAI Rome 11.800 (Eng, Da, Sw, Esp 1935-2020) 53453 at 1943 by Jim Cash; Radio Beijing, China 11.500 (Russ, Ger, Eng 1700-2155) 43443 at 2000 by Ken Whayman; Radio

## Tropical Band DX Chart

Freq kHz	Station	Country	UTC	DXer
2.420	R Sao Carlos	Brazil	0252	J
2.560	Xinjiang	China	2355	D
3.210	R Mozambique	Mozambique	0327	J
3.215	R Orange	S Africa	2040	J, Q
3.220	R HCJB Quito	Ecuador	0332	J
3.230	ELWA Monrovia	Liberia	2200	Q
3.255	BBC via Maseru	Lesotho	0334	J
3.270	SWABC 1, Namibia	S.W Africa	0337	J
3.300	R Cultural	Guatemala	0253	C, J
3.315	SIBS Freetown	Sierra Leone	2210	Q
3.915	BBC Kranji	Singapore	1900	C, H, Q
3.955	BBC Daventry	England	2045	A, C, G, K, P
3.960	RFE/RL Munich	W Germany	0015	C
3.965	RFI Paris	France	2050	C, K
3.980	VOA Munich	W Germany	0600	C, P
3.985	R Beijing, China	via SRI Berne	2100	D, F
3.985	SRI Berne	Switzerland	0640	P
3.995	DW Cologne (Julich)	W Germany	2100	C, K
4.010	R Frunze 1	USSR	1604	I
4.040	R Yerevan 1	USSR	1615	I
4.055	R Moskva 1 (Kalinin)	USSR	1937	C
4.220	PBS Xinjiang	China	2340	D
4.460	R Beijing	China	2130	Q
4.500	Xinjiang	China	2340	D
4.610	R Khabarovsk	USSR	2113	B
4.650	R Santa Ana	Bolivia	2357	D
4.735	Xinjiang	China	2230	D, E
4.740	R Afghanistan	via USSR	1926	C, Q
4.760	ELWA Monrovia	Liberia	2040	L
4.765	R Moscow	via Cuba	0554	C
4.770	FRCN Kaduna	Nigeria	2000	Q
4.790	R Atlantida	Peru	0157	D
4.795	R Douala	Cameroon	2040	L, Q
4.815	R diff TV Burkina	Duagadougou	1905	D, L
4.820	La Voz Evangelica	Honduras	0424	C, E
4.820	R Moskva 4 (Khanty-M)	USSR	2300	E
4.825	R Cancao Nova	Brazil	0157	I
4.825	R Moscow	USSR	0007	C
4.830	Gaborone	Botswana	2040	J, L, Q
4.830	R Tachira	Venezuela	0212	C, D
4.832	R Relej	Costa Rica	0507	C, D, J, Q
4.835	RTM Bamako	Mali	2050	C, E, L
4.845	ORTM Nouakchott	Mauritania	2050	C, E, L
4.850	R Yaounde	Cameroon	2040	C, E, L
4.865	PBS Lanzhou	China	2120	D, Q
4.865	Caracol	Colombia	0526	C
4.865	V of Cinaruco	Colombia	0208	D, J
4.870	R Cotonou	Benin	2040	O, E, L
4.870	SLBC Colombo	Sri Lanka	1900	O
4.880	SABC Radio 5	S Africa	1900	Q
4.885	R Clube do Para	Brazil	0314	J
4.885	Voice of Kenya	Kenya	1920	L
4.900	V de la Rev Conakry	Guinea	2040	E, L
4.905	R Relogio, Rio	Brazil	0002	D
4.905	R Nat N'djamena	Chad	1907	C, L
4.910	R Zambia, Lusaka	Zambia	2035	L
4.915	R Anhanguera	Brazil	0522	C
4.915	R Ghana, Accra	Ghana	2040	L
4.915	Voice of Kenya	Kenya	1920	L
4.930	RRI Surakarta, Java	Indonesia	2342	I
4.930	R Moscow	USSR	1816	C
4.935	Voice of Kenya	Kenya	1920	B, C, L, M
4.940	R Kiev 2	USSR	1920	C, L
4.945	Caracol, Neiva	Colombia	0200	Q
4.958	R Baku	USSR	1915	C, M
4.970	R Rumbos, Caracas	Venezuela	0316	J
4.975	R Uganda, Kampala	Uganda	2040	L
4.980	Ecos del Torbes	Venezuela	0005	D, J
4.985	R Brazil Central	Brazil	0320	C, J
4.990	AIR via Madras	India	0005	O
4.990	FRCN Lagos	Nigeria	1925	C, D, H, L, N
5.005	R Nacional, Bata	Eq Guinea	1920	C, L, N
5.010	R Malagasy	Madagascar	1800	Q
5.020	La Voix du Sahel	Niger	0630	D
5.035	R Bangui	C. Africa	1925	L
5.035	R Alma Ata	USSR	1947	C
5.040	R Tbilisi 1	USSR	1820	C
5.050	SBC Singapore	Singapore	2345	I, O
5.055	Faro del Caribe	Costa Rica	0500	C
5.055	RFO Cayenne (Matoury)	French Guiana	0500	Q
5.060	PBS Xinjiang	China	2245	D
5.075	Caracol Bogota	Colombia	0453	C, E, J
5.163	R Beijing	China	2100	C
5.260	R Alma Ata 2	USSR	1947	C

Ted Agomber: Grundig Sensit 400 + random wire.  
Thomas Barnett: Kenwood R2000 + random wire.  
Leo Barr: Matsui MR4099 + Spooler Loop.  
Darren Beasley: Philips D2325 + Hexagon loop or a.t.u. + 10m random wire.  
Donald Blackill: Philips D2325 portable.  
Kenneth Buck: Lowe HF225 + random wire or home built L.F. set + loop.  
Andy Cadier: Saisho SW5000 + 40m random wire or home built antenna.  
Scott Caldwell: Saisho 2000 + random wire or Toshiba TR-111 + loop.  
Derek Carter: Matsui MR4099 + random wire.  
Jim Cash: Kenwood R5000 + dipole or Sony AN-1 active antenna.  
Robin Clark: Saisho SW5000.  
Matthew Clarke: Sony Walkman radio cassette.  
Adrian Dan: Philips 752 digital car radio + whip antenna on car.  
David Edw. rdeen: Trio R600 + trap dipole 22m long.  
Alf Gray: Coder CR70 + Coder a.t.u. + Evans rod antenna.  
Bill Griffiths: Matsui MR4099 + Sony AN-1 active antenna.  
Brian Hallett: Trio R2000 + 10m random wire.  
Simon Hamer: Grundig S1400 + 13m wire.  
Geoff Harris: Home-built reflex receiver + hexagon loop.  
Robin Harvey: Matsui MR 4099 + SW loop.  
Francis Heame: Sharp GFA3 cassette radio + random wire.  
Marc Henry: Roberts R25 antenna.  
Simon Holland: Sangean AT5-6034 portable + built-in whip.  
Sheila Hughes: Panasonic DR48 + 15m inverted L or Vega 206 portable.  
Rhoderick Ilman: Sony ICF 7600DS + 23m random wire.  
George Millmore: Tartung TMR 7602 portable.  
Dick Moon: Icom R-79.  
John Nash: Kenwood R5000 + DeLong AD370 active antenna.  
Ire Odoo: Philips D2325 portable.  
Fred Pellant: Trio R2000 + random wire in loft.  
John Parry: Realistic DX-400 + 33m random wire.  
Roy Patrick: Lowe HF 125 + 20m wire.  
Ron Pearce: Restored Philco Domestic receiver (Class 13471).  
Philip Rambaut: Int. Marine Radio R.700M + random wire.  
Kenneth Reeca: Icom R9000 or Kenwood R5000 + delta loop.  
Alan Roberts: Panasonic RF-B40 portable + whip.  
John Sadler: DX-400 or Omega 4020 + a.t.u. + s.w. loop.  
Tim Shirley: Trio R600 + random wire.  
Chris Shorten: Matsui MR 4099 portable + 10m wire.  
Alan Smith: Matsui MR4099 + Mizuno KC-3 a.t.u. + vertical dipole.  
Mike Smith: Lowe HF 225 + ATU + random wire.  
Roy Spencer: Realistic DX-400 + 5m wire in loft.  
Cliff Stapleton: Trio R1090 + dipole or 25m random wire.  
John Stevens: Hammarlund HQ 180 or Icom R70 + random wire.  
Darran Taplin: Lowe HF225 + Global 1900 a.t.u. + 30m random wire.  
Lucian Thomas: Panasonic RF-1680L + short wire.  
Phil Townsend: Lowe SRX-30 + a.t.u. + 10m random wire.  
Ted Walden-Vincent: JVC twin tape portable.  
Ken Whayman: Realistic DX-440 or Panasonic RF2200 + 15m inverted L.  
Neil Wheatley: Sangean AT5-6034 portable.  
Graham White: Sony ICF 2001D portable or Philips 752 car radio.  
Jim Willett: RCA AR77 + Diawa CL-22 a.t.u. + X dipole in loft.  
Harold Wood: Philips D2325 portable + whip.  
Julian Wood: Trio R6000 + Yamauchi TR1750 a.t.u. + 3m wire.



## COMPUTERS AND RADIO

Improve computer decoding of RTTY, CW & SSTV signals with our audio filter

RTTY only or CW only (unboxed but fully built & tested) ..... £7.00  
 RTTY/CW (ditto and with tuning) ..... £13.50  
 LED) ..... £8.00  
 CONSTANT LEVEL AMPLIFIER ..... £8.00

RTTY Super or SSTV Super. This unit has an adjustable constant level output. No need for constant adjustment of volume control ..... £19.50  
 RTTY/CW Super. As above but switchable between RTTY & CW ..... £23.00

**RMS-3 THE FILTER** RTTY/CW/SSTV with AGC in one superb unit ..... £35.00  
 When ordering above units, please state software supplier. This will enable us to supply correct filters.

**TERMINAL UNITS RECEIVE ONLY (RTTY/CW)** ..... £45.00

The above units provide audio, TTL and OCL outputs on RX. The output level is constant and full output is achieved with inputs between 10mV and 5V of audio.  
**SPECTRUM 128 + 2**  
 CASSETTE PORT ADD-ON. Enables owners of the Spectrum 128 + 2 to run existing programs which require the audio signal being fed into the cassette port. There is no need to open the computer, simply connect to the expansion port ..... £19.50

For further details of these and our other products, send an sae or see earlier advertisements

# J. & P. ELECTRONICS LTD.

Unit 45, Meadowmill Estate, Dixon Street,  
 Kidderminster DY10 1HH Tel: (0562)753893





(0202) 665524

**PRACTICAL WIRELESS...**  
**THE RADIO MAGAZINE... ON SALE AT YOUR LOCAL NEWSAGENT NOW, OR WHY NOT TAKE ADVANTAGE OF A JOINT SUBSCRIPTION WITH SWM AND SAVE MONEY!**  
**Details from PW Publishing Ltd. Enefco House, The Quay, Poole Dorset BH15 1PP. TEL: (0202) 665524**

## AVIATION ENTHUSIASTS AVIATORS - LISTENERS

AIR TRAFFIC CONTROLLERS - on hand to help 'Guide' you towards an interesting & rewarding pastime. AIR BAND RADIOS-SCANNERS etc. Over 20 to choose from: AERIALS & ACCESSORIES: MAPS - BOOKS: CHARTS: CAA PUBLICATIONS: POSTCARDS: MODELS: TIE PINS & BADGES: AIRBAND TRANSCEIVERS: PHOTOS: PILOTS PRODUCTS

Information pack only **50p.**

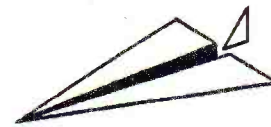

### AIR SUPPLY

**83b High Street, Yeadon, Leeds LS19 7TA. TEL: 0532-509581**  
 Shop just two minutes from Leeds Bradford Airport.  
 (Closed Wednesday & Sunday).

## VHF & UHF ENTHUSIASTS



Our Audio Switch Unit will link your RX & Tape Recorder to collect signals while you sleep or work. A boon to Airbanders  
 Requires 12V. DC @ 60mA.  
**SUPPLIED BUILT & TESTED COMPLETE WITH AUDIO LEADS.**  
 ACCESS & VISA ..... £48.95 inc P & P.  
 Or send S.A.E. for details to: **AEROTRONIC CONTROLS LTD.**  
 HALESFIELD 22, TELFORD, SHROPSHIRE TF7 4QX. (0952) 586329

## SCANNING?

HAVE YOU NOTICED THAT THERE IS SO MUCH RADIO SPECTRUM TO SCAN, AND LITTLE OR NO INFORMATION AVAILABLE ON WHERE THE REALLY INTERESTING TRAFFIC IS? LOOK NO FURTHER — WE OFFER A WIDE RANGE OF FREQUENCY LISTINGS AND BAND PLANS.  
 FOR A FREE COPY OF OUR LATEST CATALOGUE JUST SEND AN A4 SAE TO:  
 S.S.C. P.O. BOX 71 BOURNEMOUTH DORSET BH9 1DT.  
**STOP PRESS:** Confidential Band Plan NOW OUT. Same Price £19.50 But this time loads more spot frequencies. Order yours today.



## CENTRE OF ENGLAND AUTUMN MOBILE RALLY 1990

Ham Radio, Computer, TV & Electronics • Displays by Traders • Bring & Buy • Catering • Ample Free Parking • Special Event Station

Held **SUNDAY, SEPTEMBER 23rd, 10.30am** Trader Enquiries Tel: 0952 598173

**British National Motorcycle Museum by N.E.C., Junction 6, M42**

Admission £1 (R.A.I.B.C./O.A.P.s FREE) ★ Concession on price to Museum

## INDEX TO ADVERTISERS

Aerial Techniques ..... 36	Colomor Electronics ..... 54	J. & P. Electronics ..... 56	..... 21
Aerotronic Controls ..... 56	Comar ..... 45	Javiation ..... 28	Rylands F G ..... 54
Air Supply ..... 56	Datong ..... 48	Johnsons Shortwave Radio ..... 32	S E M ..... 54
Alyntronics ..... 54	Dewsbury Electronics ..... 50	Klingenfuss Publications ..... 43	SRP Trading ..... 36
ARE ..... 13	Dressler Communications ..... 27	Lake Electronics ..... 54	SSC ..... 56
ASK Electronics ..... 44	Elliott Electronics ..... 54	Link Electronics ..... 54	Solid State Electronics ..... 36
BBC ..... 28	EMP ..... 23	Lowe Electronics ..... 8,9	South Midlands Communications ... ..... Cover iv
Beckett. P ..... 46	ERA ..... 32	Medium Wave Circle ..... 43	Spacotech ..... 45
Bredhurst Electronics ..... 27	Flightdeck ..... 36	Nevada Communications ..... ..... Cover ii, 18, 19, 39	Stephens James ..... 52
Centre of England Rally ..... 56	Garex Electronics ..... 43	Practical Wireless ..... 56	Technical Software ..... 45
Capco ..... 28	Howes. CM Communications ..... 43	Rapid Results College ..... 48	Ward Reg & Co ..... 52
Circuit ..... 23	Icom (UK) ..... Cover iii	Raycom Communications Systems	Waters & Stanton ..... 35

PUBLISHED on the fourth Thursday of each month by PW Publishing Ltd., Enefco House, The Quay, Poole, Dorset BH15 1PP. Printed in England by KSC Printers Ltd, Tunbridge Wells, Kent. Distributed by Seymour, Windsor House, 1270 London Road, Norbury, London SW16 4DH, Tel: 01-679 1899, Fax: 01-679 8907, Telex: 8812945. Sole Agents for Australia and New Zealand - Gordon and Gotch (Asia) Ltd., South Africa - Central News Agency Ltd. Subscriptions INLAND £19.00, EUROPE £21, OVERSEAS (by ASP) £22, payable to SHORT WAVE MAGAZINE, Subscription Department, PW Publishing Ltd., Enefco House, The Quay, Poole, Dorset BH15 1PP. SHORT WAVE MAGAZINE is sold subject to the following conditions, namely that it shall not, without the written consent of the publishers first having been given, be lent, re-sold, hired out or otherwise disposed of by way of trade at more than the recommended selling price shown on the cover, and that it shall not be lent, re-sold, hired out or otherwise disposed of in a mutilated condition or in any unauthorised cover by way of Trade, or affixed to or as part of any publication or advertising, literary or pictorial matter whatsoever.

# SEEN & HEARD

Damascus, Syria 12.085 (Ger, Fr, Eng 1805-2105) 43434 at 2025 by Cliff Stapleton; Radio Sophia, Bulgaria 11.660 (Ger, It, Fr, Eng 1830-2100) 55544 at 2044 by Andy Cadier; Radio Romania Int, Bucharest 11.940 (Ger, Eng, Fr 1900-2126) SIO333 at 2110 by Alf Gray; Radio Finland via Pori 11.755 (Fin, Sw, Ger, Eng, Fr 0700-2230) 55444 at 2111 by Ike Odoo; Radio Japan via Moyabi, Gabon 11.835 (Jap, Eng 2200-0000) SIO333 at 2300 by Francis Hearne in Bristol.

Some of the many broadcasts to other areas stem from TWR Bonaire, Ned. Antilles 11.930 (Eng to USA 0300-0430), logged as 32232 at 0412 by Kenneth Reece; RBL via Wusterhausen, GDR 11.785 (Eng, Ger to Middle East 0745-0945) 44444 at 0942 by Leo Barr; Radio Korea via Sackville, Canada 11.715 (Eng to USA 1030-1100) 44334 at 1040 by Chris Shorten; Radio Australia via Shepparton 11.910 (Eng to SE Asia 1100-1300) 33232 at 1126 by Rhoderick Illman; KFBS Saipan, N.Mariana Islands 11.650 (Russ to

N.Asia 0900-1400) SIO211 at 1245 by Philip Rambaut; FEBA Radio, Seychelles 11.860 (Am, Or, Tig to E.Africa 1631-1831) 44444 at 1800 by Mike Smith in Cambridge; Voice of Greece, Athens 11.645 (Gr, Eng to Africa 1800-1850) SIO444 at 1840 by Kenneth Buck; Voice of the UAE in Abu Dhabi 11.985 (Ar, Eng to USA 2200-0200) 54444 at 2202 by Darren 2115 by Francis Hearne.

While checking the 7MHz (41m) band, Harold Wood rated WYFR via Okeechobee, Florida 7.355 (Russ, Ger, Eng to Europe 0400-0745) as SIO544

at 0530; Darran Taplin logged AIR via Aligarh, India 7.412 (Hi, Eng to Europe 1845-2230) as 45433 at 2201; Leo Barr noted Radio Australia via Carnarvon 7.240 (Eng to S.Asia 1700-2100) 33333 at 1759; Neil Wheatley rated WHRI South Bend USA 7.315 (Eng, Sp to Europe 0000-0600) as SIO434 at 0030.

In the 6MHz (49m) band, Sheila Hughes noted Radio Korea, Seoul 6.480 (It, Fr, Kor, Ar, Port, Eng, Ger, Sp 1545-2345) as 54444 at 2030; Bill Griffith logged Radio Nacional, Brazil 6.180 (Port to S.America 0900-0100) as 54444 at 2200.

Abbreviations	
Am	Amharic
Ar	Arabic
Chin	Chinese
Cz	Czechoslovakian
Dan	Danish
Du	Dutch
Eng	English
Esp	Esperanto
Far	Farsi
Fin	Finnish
Fr	French
Ger	German
Gr	Greek
Ha	Hausa
Heb	Hebrew
Hi	Hindi
Hung	Hungarian
It	Italian
Jap	Japanese
Kir	Kirghiz
Kor	Korean
Norw	Norwegian
Or	Oromo
Pa	Pashto
Port	Portuguese
Russ	Russian
So	Somali
Sp	Spanish
Sw	Swedish
Taj	Tajik
Tel	Telugu
Tig	Tigrinya
Tur	Turkish
Ur	Urdu
Viet	Vietnamese
Yi	Yiddish
Yu	Yugoslavian

## Station Addresses

BBC Radio Cambridge, Broadcasting House, 104 Hills Road, Cambridge CB2 1LD.

ILR Invicta Sound (Coast AM), 37 Earl Street, Maidstone, Kent ME14 1PF.

Radio Bangladesh, NBA House, Shahbag Avenue, Dhaka-1000, Bangladesh.

Radio Budapest, P.O.Box 1, H-1800 Budapest, Hungary.

Radio Yugoslavia, P.O.Box 200, 11000 Beograd, Yugoslavia.

Voice of America, Washington, DC 20547, USA.

## LW MARITIME RADIO BEACONS

Brian Oddy G3FEX

Three Corners, Merryfield Way, Storrington, West Sussex RH20 4NS

There are some very long hauls noted in the chart this time! The extensive log sent along by John Macdonald was compiled at his home location in Bettyhill, Scotland, which is probably one of the most favourable locations for I.w./m.w. Dxing in the UK - it is close to the sea and far from urban noise!

John has spent much time in trying to improve his equipment. In

January he obtained a new 'Radio West' loop, which proved to be more sensitive than the 'Worcester' loop which he used last year. Nevertheless, he says his progress in adding new

beacons to his list was very slow until he purchased an MFJ 1020A active antenna, which he uses as an 'active pre-selector', or tunable pre-amplifier, with an outdoor 10m wire running N/

S. A marked improvement in reception was immediately apparent with this system and subsequently it has enabled him to add many 'new' beacons to his list.

Recent DXpeditions to Sheigra, which is quite close to Bettyhill, produced such remarkable m.w. transatlantic Dx results (see page 52, June '90 SWM) that John decided to try searching for North American I.w.

## Long Wave Maritime Radiobeacon Chart

Freq kHz	Call	Station Name	Location	DXer	Freq kHz	Call	Station Name	Location	DXer	Freq kHz	Call	Station Name	Location	DXer
285.0	GY	Castle Breakwater	Channel Is	G*	296.5	NP	Nieuwpoort W Pier	Belgium	B*	305.7	LS	Hirtshals	Norway	C,E
286.0	T	Ambrose LS	N York USA	E	296.5	OH	Old Head Kinsale	Ireland	D*,E	305.7	OE	Ostende	Belgium	H
287.3	BC	Bloscow Roscoff	N France	G	296.5	SB	South Bishop LH	Pembrok	C	305.7	SW	Skagen	Norway	C
287.3	BT	Bjartangar	Iceland	E	298.8	AD	Ameland	Holland	C	305.7	WH	West Hinder	off Belgium	A
287.3	BY	Bressey LH	Shetland Is	G*	298.8	BL	Burt of Lewis	Is of Lewis	C	308.0	BD	Barra Head LH	Is of Barra	C,G
287.3	CM	Cromer LH	Norfolk	E,G*	298.8	CW	Cape Wrath LH	Sutherland	C	308.0	CA	Pointe de Creach	France	C,G
287.3	CR	Channel LV	??	B*	298.8	FA	Farstugrunden	Sweden	C	308.0	DG	Drogden	Denmark	C
287.3	DG	Douglas Pier LH	I.O.M	C,D,E	298.8	HO	Hornbjarg	Iceland	C	308.0	GL	Eagle Island LH	W.Ireland	C,G*
287.3	FH	Fruhoimen	Norway	E	298.8	KN	Kallan	Finland	C	308.0	GR	Grimesy	Iceland	C
287.3	FN	Walney Island	off Lancs	D,E	298.8	LK	Sule Skerry LH	off Orkney	C	308.0	HD	Hendanes Vagsoy	Norway	G
287.3	GA	Outer Gabbard LV	off Suffolk	A*,B*	298.8	LZ	Lizard LH	S.Cornwall	C	308.0	HK	Texel	Germany	B*
287.3	HN	Hornafjordur	Iceland	A*,B*	298.8	MF	Muckie Flugga LH	Shetland Is	C	308.0	MZ	Mizen Head LH	S.Ireland	B*
287.3	LV	Dudgeon LV	off Norfolk	C	298.8	MN	Hammerodde	Denmark	C	308.0	RR	Round Island LH	Nr Cornwall	B*,C
287.3	PS	Point Lynas	Anglesey	E	298.8	OB	Hoburg	Scain	C	308.0	TY	Tory Island LH	N.Ireland	C,D
287.3	SK	Smith's Knoll LV	off Norfolk	A*,C	298.8	PE	Penlee Pt	UK	C	308.0	VA	Vieland	Norway	C
289.6	D	Rota	Spain	G*	298.8	QS	Casquets LH	Channel Is	B*,E	308.0	WL	Hemsoe	Sweden	E
289.6	FD	Fotra LH	F. of Forth	C,G*	298.8	RD	Roches Douvres LH	Channel Is	C	310.3	AL	Pointe d'Ailly LH	France	E,J*
289.6	SL	Slatteroy	Norway	E	298.8	SD	Start Point LH	S.Devon	C	310.3	BO	Boulogne	France	A
289.6	CP	Thyboroen LH	Denmark	A,C	298.8	SP	Start Point LH	France	C	310.3	DU	Dungeness LH	S.Kent	A,B*,F,H,J*
291.9	IN	St. Catherine's Pt	I.O.W	A*,B*,F,J*	298.8	UD	Cabo Salou	France	C	310.3	GD	Girdle Ness	Aberdeen	C
291.9	ER	Pointe de Ver LH	N.France	B*	301.1	CN	Cregneish	I.O.M	C,D,E,I	310.3	GU	Cap Gris Nez	France	E
291.9	FG	Pointe de Barfleur	N.France	A*,B*,F,J*	301.1	GE	Skarvoy egersund	Norway	C	310.3	LR	Hals Barre LH	Denmark	E
291.9	KD	Kinnairds Head LH	Aberdeen	C	301.1	HO	Hirsholm Main LH	Denmark	C	310.3	LP	Laeso Rende LH	Denmark	E
291.9	MH	Mahon, Minorca	Balearic Is	J*	301.1	NF	North Foreland LH	E.Kent	A*,H,J	310.3	PH	Cap d'Alprech	France	A,B*,F,H
291.9	NR	N.Ronaldsday LH	Orkney Is	C	301.1	PS	Cabo Penas LH	N.Spain	F	310.3	VI	Cabo Vilano	Spain	A
291.9	OM	Stroma Pt. LH	Caithness	C	301.1	PY	Point of Ayre LH	I.O.M	C,D,I*	312.6	FN	Feistein	Norway	C
291.9	PB	Portland Bill LH	Dorset	B*	301.1	SR	Skerries LH	Anglesey	C	312.6	GU	Geltungane	Norway	C
291.9	SB	Sumburgh Head	Shetland Is	C	301.1	SU	South Rock LV	Co Down	C	312.6	KH	Kish Bank	E.Ireland	C,D*,E
291.9	TI	Cap d'Antifer	France	B*	301.1	TN	Tresvikpynten	Norway	C	312.6	MA	Marstein	Norway	C
294.2	AH	Altacarry Head LH	Antrim	C,I*	301.1	UN	Understen	Sweden	E	312.6	MB	Nab Tower LH	off Sussex	B*,G
294.2	AL	Almagrundet LH	Sweden	C	301.1	WK	Wicklow Head LightCo	Wicklow	B*,C,D*,J	312.6	PT	Souter Pt	Durham	C
294.2	DA	Placida LH	Is of Arran	C,G,I*	303.4	FB	Fiamborough Hd LH	E.Yorkshire	C,E	312.6	RB	Cherbourg	France	B*
294.2	ER	Eierland LH	Holland	C	303.4	FP	Fife Ness Point	Fife	C	312.6	SM	Skagata	Iceland	E
294.2	EG	Eilean-Glas LH	Is of Harris	E	303.4	HI	Helsinki	Finland	C	312.6	SR	Stubbenkammer	Germany (E)	C
294.2	MR	Marinenleuchte	Germany	E	303.4	HK	Hekkingen	Norway	C	312.6	UT	Utsira	Norway	C,G
294.2	MW	Mew Island LH	off Co.Down	C,E	303.4	KD	Kalbadagrund	Finland	C	312.6	VR	Vitvaer	Norway	C
294.2	NO	Cabo de la Nao LH	Spain	K	303.4	LT	Longstone LH	Berwick	C	313.5	KU	Nordvalen	Sweden	E
294.2	PA	Cabo de Palos LH	Spain	K	303.4	ON	Orregrund	Finland	C	314.5	DV	Grundkallen	Sweden	E
294.2	RH	Rimns of Islay	Is of Islay	C,I*	303.4	SJ	Souter Light	Sunderland	C	314.5	SS	Simpnasklub	Sweden	E
296.5	BN	Blavandshuk LH	Denmark	C	303.4	SL	Spurn LV	off Yorks	B*,J	318.5	RS	Kolkasrags	USSR	E
296.5	BN	Ballycotton	S.Ireland	E	305.7	OB	Corbiere	Jersey C.I	C	318.5	KL	Ristna	USSR	E
296.5	HM	Hanstholm	Denmark	C,E	305.7	FR	Faerder LH	Norway	C	318.5	SV	Soerne	USSR	E
296.5	HO	Tennholm	Norway	E	305.7	RS	Rail's LV	off Kant	A,H,J	318.5	LEC	Stavanger	Norway	B*,C,D*,H
296.5	KL	Sklinna	Norway	E	305.7	KY	Okoy LH	Norway	C	412.0	AS	Aarflus LH	Denmark	D*
296.5	LA	Lista LH	S.Norway	C,G*	305.7	L	Torre de Hercules	Spain	E	414.0	FK	Frederikshavn Blkw	Denmark	D*
296.5	LS	Lundy's S.LH	off N.Devon	B*	305.7	LG	Landegode LH	Norway	E					
296.5	NK	Inchkeith	F. of Forth	C	305.7	LL	Halloe LH	Norway	C,E					

### DXers:-

- (A) Thomas Barnett, Slough.
- (B) Darren Beasley, Bridgwater.
- (C) Kenneth Buck, Edinburgh.
- (D) Simon Holland, Douglas, I.O.M.
- (E) John Macdonald, Thurso.

- (F) Fred Pallant, Storrington.
- (G) Tim Shirley, Bristol.
- (H) Alan Smith, Northampton.
- (I) John Stevens, Largs.
- (J) Darran Taplin, Brencley.
- (K) Jurgen Thiel, Javea, Spain.

Note. Entries marked \* were logged during darkness. All other entries were logged during daylight.



# SEEN & HEARD

maritime radiobeacons! Having checked the band after midnight during several nights, he picked up a beacon signing 'T' in a particular sequence, just up from 286kHz. A check with the American Beacon Guide confirmed the pattern as that of Ambrose LS!

Apparently there are two other beacons signing T, but they follow a different pattern. John informs me that the location of Ambrose LS is shown on Plate 103 of The Times Atlas of the World.

The beacon log sent along by Alan Smith in Northampton should help to convince the listeners who are located well inland that one does not have to live on the coast to enjoy this aspect of our hobby!

Alan used a Matsui MR4099 portable with just the built-in ferrite rod antenna to compile his list, which just goes to show what can be achieved with simple equipment! In Slough, Thomas Barnett says he

finds it takes time, patience and a keen ear, but he logs them eventually. Kenneth Buck is wondering if he has logged all the maritime beacon signals which reach Edinburgh, as he listened for seven hours and failed to add any new ones to his list!

Reporting from Bridgwater, Darren Beasley says "I have completed my long wave a.t.u. and it is working very well indeed. What makes it even more pleasing for me is that I designed and built it myself".

During an initial check Darren found that he could only receive a few beacons with his Philips D2935 receiver (see page 60, May '90 SWM), but the addition of his a.t.u. and a 10m random wire antenna has enabled him to log 21 beacons!

He says "There are some more beacons I have heard, but I have not been able to identify them as yet, as the signals are very weak. Also I have not explored the band in any detail during dark hours, so that may enable

me to hear some more beacons."

Several listeners have been trying this aspect of our hobby for the first time. In Brenchley, Darran Taplin found that the S7 level of electrical interference in his area during the day prevents him from hearing any of the beacon signals other than that from Dungeness lighthouse (DU) on 310.3kHz, which is S9+20dB!

However he noted a marked fall in the interference level after dark, so he decided to check the band then and was very surprised at the number of beacons he could receive. Using his Lowe HF225 receiver, Global AT-1000 a.t.u. and a 30m inverted L antenna, Darran logged some interesting beacon signals including MH on 291kHz, which stems from Mahon, Menorca in the Western Mediterranean!

The beacon signal FR, radiated from the Faerder lighthouse in Norway on 305.7kHz, was heard by Fred Pallant while exploring the band

for the first time in Storrington. He also picked up some of the beacon signals from sites along the coastline of the UK and France. Fred used a Trio R2000 receiver with a random wire in the loft.

Another newcomer to the band is Simon Holland in Douglas, IOM. No doubt the clear sea paths from his location will help him to log many of the beacons along the western coastline of the UK and those in S. Ireland! Simon tried listening during daylight and after dark and he compiled an interesting log which includes beacons in Denmark and Norway.

Some of the entries in the logs proved to be Aeronautical Radiobeacons, which cannot be included in the chart.

It is worth noting that most of them have three letter callsigns, whereas nearly all of the Maritime Radiobeacons have two letter callsigns.

# BOOKCASE

## AN INTRODUCTION TO VHF/UHF FOR RADIO AMATEURS BP281 I.D. POOLE

Bernard Babani (publishing) Ltd. ISBN 0-85934-226-3  
101 pages. £3.50

Available from the SWM Book Service, 75p post and packing

The book is aimed primarily at the newcomer, giving an outline of the essentials of v.h.f./u.h.f. operation. However, it should also be of use to the more experienced v.h.f./u.h.f. user as a reference.

The book has nine chapters. It covers topics including propagation, aerials, transmitters and receivers, band and bandplans, DXing, mobile and repeater operation as well as data modes. To finish the book there is a chapter on scanners and there is also an appendix which includes useful abbreviations and codes.

### An Introduction to VHF/UHF for Radio Amateurs

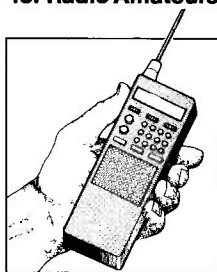

## A BEGINNERS GUIDE TO MODERN ELECTRONIC COMPONENTS BP285

R.A. PENFOLD

Bernard Babani (publishing) Ltd. ISBN 0-85934-230-1  
166 pages, £3.95

Available from the SWM Book Service, 75p post and packing

It is easy for newcomers to electronics to become confused by the wide range of components currently available. There are now a great many different types of component on offer in shops and catalogues, often with numerous variations on each type. It can be difficult to know your carbon compositions from your metal films, and your diacs from your triacs! This book covers a wide range of modern components, including: Resistors (including potentiometers); Capacitors; Inductors; Diodes (including Zeners and Varicaps); Transistors (silicon and germanium); Opto electronic devices; Operational amplifiers; Logic integrated circuits; Loudspeakers and microphones as well as meters.

The basic functions of the components are described, but this is not a book on electronic theory and does not assume that the reader has an in-depth knowledge of electronics.

## MOBILE RADIO SERVICING HANDBOOK

Roger Belcher, Mike Fitch, David Ogley, Geoff Varrall  
Heinemann Professional Publishing. ISBN 0-434-92187-4

281 pages hard covered, £25.00  
Available from good book shops

The fast changing component and system technology of mobile radio communications is having a major impact on the way in which equipment is installed, commissioned, serviced and maintained. The four authors have combined to supply the technician or engineer with sufficient information to be able to undertake, or plan, repair-and-maintenance work on modern mobile radio systems, with hand-held or vehicle mounted mobiles. In addition, the book covers the impact of data over radio, cellular radio and trunking technologies on servicing, diagnosis and repair procedures.

Essential background topics covered include radio theory, a.m. and f.m., radio wave propagation, reception and demodulation, fundamentals of receiver and transmitter systems, principles of transmitter and receiver design, synthesiser techniques, selective tone signalling and the digital signalling control and access protocols of cellular and trunked radio, but this book is intended primarily as a source of readily accessible information on how to fault-find and repair mobile radio equipment - mobiles, base stations and antennas - to circuit modules and component level.

## THE ATV COMPENDIUM MIKE WOODING G6IQM

The British Amateur Television Club  
ISBN 0-9513779-1-4

104 pages. £3.00

Available from the SWM Book Service,  
75p post and packing

For something approaching the past decade, the BATC has been publishing handbooks, dealing exclusively with the world of amateur television. The author has tried to include projects that use state-of-the-art devices and techniques, without precluding those who do not own sophisticated test equipment or have degrees in mechanical engineering.

There is no 70cm section though. This is because there is little in the way of new things for 70cm ATV, but plenty for the other bands such as 3cm.

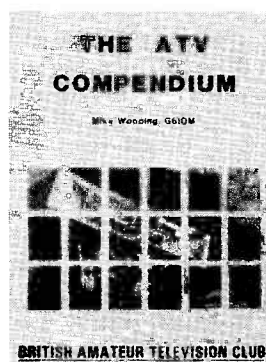

The books listed have been selected as being of special interest to our readers. They are supplied from our editorial address direct to your door. Some titles are overseas in origin.

## HOW TO ORDER

**POST AND PACKING:** add 75p for one book, £1 for two or more books, orders over £25 post and packing free. Overseas readers add £1.50 for one book, £1.50 for two or more for surface mail (airmail) and send a postal order, cheque or international money with your order (quoting book titles and quantities). In F.W. Publishing Limited, FREEPOST, Enrico House, The Quay, Poole, Dorset BH15 1PP. Please make your cheques payable to Short Wave Magazine, payment by Access, Mastercard, Eurocard or Visa also accepted on telephone orders to Poole (0202) 665524. Books are normally dispatched by return of post but please allow 10 days for delivery. Prices correct at time of going to press. Please note: all payments must be made in Sterling.

### RADIO

\* A recent addition to our Book Service. O/P = Out of print, O/S = Out of stock.

#### AIR & METEO CODE MANUAL

**10th Edition. Joerg Klingenfuss**  
Detailed descriptions of the World Meteorological Organisation Global Telecommunication System operating FAX and RTTY meteo stations, and its message format with decoding examples. Also detailed description of the Aeronautical Fixed Telecommunication Network amongst others. 289 pages. **£14.00**

#### BETTER RADIO/TV RECEPTION

**A. Nallawalla, A. T. Cushen and B. D. Clark**  
An Australian book giving guidance and advice to listeners seeking reliable reception of distant radio stations, and to DX listening hobbyists. 134 pages. **£9.95**

#### BETTER SHORTWAVE RECEPTION (USA)

**W. S. Orr W6SAI and S. D. Cowan W2LX**  
Receivers, antennas, propagation, QX listening techniques for the short waves and v.h.f. 158 pages. **O/S**

#### PASSPORT TO WORLD BAND RADIO 1990

This book gives you the information to explore and enjoy the world of broadcast band listening. It includes features on different international radio stations, receiver reviews and advice as well as the hours and languages of broadcast stations by frequency. 398 pages. **O/S**

#### SCANNERS (Third Edition)

**Peter Rouse GU1DKD**  
A guide for users of scanning receivers, covering hardware, antennas, accessories, frequency allocations and operating procedures. 245 pages. **£7.95**

#### SCANNERS 2

**Peter Rouse GU1DKD**  
The companion to Scanners, this provides even more information on the use of the v.h.f. and u.h.f. communications band and gives constructional details for accessories to improve the performance of scanning equipment. 216 pages. **£9.95**

#### SHORT WAVE RADIO LISTENERS' HANDBOOK

**Arthur Miller**  
In easy-to-read and non-technical language, the author guides the reader through the mysteries of amateur, broadcast and CB transmissions. 207 pages. **£7.99**

#### RADIOTELETYPE CODE MANUAL

**10th Edition. Joerg Klingenfuss**  
This book gives detailed descriptions of the characteristics of telegraph transmission on short waves, with all commercial modulation types including voice frequency telephony and comprehensive information on all RTTY systems and c.w. alphabets. 96 pages. **£9.00**

#### THE SATELLITE EXPERIMENTER'S HANDBOOK (USA)

A guide to understanding and using amateur radio, weather and TV broadcast satellites. 207 pages. **£7.50**

#### 1934 OFFICIAL SHORT WAVE RADIO MANUAL

**Edited by Hugo Gernsback**  
A fascinating reprint from a bygone age with a directory of all 1934 s.w. receivers, servicing information, constructional projects, circuits and ideas on building vintage sets with modern parts. 260 pages. **£10.15**

#### HIGH POWER WIRELESS EQUIPMENT

**Articles from Practical Electricity 1910-11**  
**Edited by Henry Walter Young**  
A reprint of interesting practical articles from the early days of radio. 99 pages. **£6.85**

### BEGINNERS

#### AN INTRODUCTION TO RADIO DXING (BP91)

**R. A. Penfold**  
How to find a particular station, country or type of broadcast and to receive it as clearly as possible. 112 pages. **£1.95**

#### BEGINNER'S GUIDE TO RADIO

**9th Edition. Gordon J. King**  
Radio signals, transmitters, receivers, antennas, components, valves and semiconductor, CB and amateur radio are all dealt with here. 266 pages. **£7.95**

#### ELECTRONICS SIMPLIFIED - CRYSTAL SET CONSTRUCTION (BP92). F. A. Wilson

Especially written for those who wish to take part in basic radio building. All the sets in the book are old designs updated with modern components. 72 pages. **£1.75**

#### THE SIMPLE ELECTRONICS CIRCUIT AND COMPONENTS Book One (BP62)

The aim of this book is to provide an in-expensive but comprehensive introduction to modern electronics. 209 pages. **£3.50**

### TELEVISION

#### THE ATV COMPENIUM

**Mike Wooding G6IQM**  
This book is for those interested in amateur television, particularly the home construction aspect. There is not a 70cm section as the author felt this is covered in other books. Other fields, such as 3cm TV, are covered in depth. A must for the practical ATV enthusiast. 104 pages. **£3.00**

#### AN INTRODUCTION TO SATELLITE TELEVISION (BP195)

**F. A. Wilson**  
Answers all kinds of questions about satellite television. For the beginner thinking about hiring or purchasing a satellite TV system there are details to help you along. For the engineer there are technical details including calculations, formulae and tables. 104 pages. **£5.95**

#### A TV-DXERS HANDBOOK (BP176)

**R. Bunney**  
Information on transmission standards, propagation, receivers including multi-standard, colour, satellites, antennas, photography, station identification, interference etc. Revised and updated 1986. 87 pages. **£5.95**

#### GUIDE TO WORLD-WIDE TELEVISION TEST CARDS

**3rd Edition. Keith Hamer & Garry Smith**  
Completely revised and expanded, this is a handy reference book for the DXTV enthusiast. Over 200 photographs of Test Cards, logos, etc., world wide. 60 pages. **£4.95**

#### SATELLITE TELEVISION INSTALLATION GUIDE

**2nd Edition. John Breeds**  
A practical guide to satellite television. Detailed guidelines on installing and aligning dishes based on practical experience. 56 pages. **£11.95**

### THEORY

#### COMMUNICATION (BP49)

**Elements of Electronics Book 5**  
**F. A. Wilson**  
Fundamentals of line, microwave, submarine, satellite, digital multiplex, radio and telegraphy systems are covered, without the more complicated theory or mathematics. 256 pages. **£2.95**

#### FILTER HANDBOOK A practical design guide

**by Stefan Niewiadomski**  
A practical book, describing the design process as applied to filters of all types. Includes practical examples and BASIC programs. 195 pages. **£25.00**

#### FROM ATOMS TO AMPERES

**F. A. Wilson**  
Explains in simple terms the absolute fundamentals behind electricity and electronics. 244 pages. **£3.50**

#### AUDIO (Elements of electronics - book 6)

**F. A. Wilson**  
This book studies sound and hearing, and examines the operation of microphones, loudspeakers, amplifiers, oscillators, and both disk and magnetic recording. Intended to give the reader a good understanding of the subject without getting involved in the more complicated theory and mathematics. 204 pages. **£3.95**

#### PRACTICAL ELECTRONICS CALCULATIONS AND FORMULAE (BP53)

**F. A. Wilson**  
This has been written as a workshop manual for the electronics enthusiast. There is a strong practical bias and higher mathematics have been avoided where possible. 249 pages. **£3.95**

#### SOLID STATE DESIGN FOR THE RADIO AMATEUR

**Wes Hayward W7ZOI and Doug DeMaw W1FB**  
Back in print by popular demand! A revised and corrected edition of this useful reference book covering all aspects of solid-state design. 256 pages. **£10.95**

#### THE ARRL ELECTRONICS DATA BOOK

**Doug DeMaw W1FB**  
Back by popular demand, completely revised and expanded, this is a handy reference book for the r.f. designer, technician, amateur and experimenter. 260 pages. **£8.95**

#### A BEGINNERS GUIDE TO MODERN ELECTRONIC COMPONENTS (BP285)

**R. A. Penfold**  
This book covers a wide range of modern components. The basic functions of the components are described, but this is not a book on electronic theory and does not assume the reader has an in-depth knowledge of electronics. It is concerned with practical aspects such as colour codes, deciphering code numbers and the suitability. 164 pages. **£2.95**

#### EVERYDAY ELECTRONICS DATA BOOK

**Mike Tooley BA**  
This book is an invaluable source of information of everyday relevance in the world of electronics. It contains not only sections which deal with the essential theory of electronic circuits, but it also deals with a wide range of practical electronic applications. 250 pages. **£8.95**

### LISTENING GUIDES

#### AIR BAND RADIO HANDBOOK (3rd Edition)

**David J. Smith**  
Listen to conversations between aircraft and ground control. The author, an air traffic controller, explains more about this listening hobby. 174 pages. **£6.99**

#### AIR TRAFFIC CONTROL

**David Adair**  
A guide to air traffic control with maps, drawings and photographs explaining how aircraft are guided through crowded airspace. 176 pages. **O/P**

#### DIAL SEARCH

**6th Edition. George Wilcox**  
The listener's check list and guide to European broadcasting. Covers m.w., l.w., v.h.f. and s.w., including two special maps. 54 pages. **£3.95**

#### FLIGHT ROUTINGS 1990

**T. T. Williams**  
Identifies the flights of airlines, schedule, charter, cargo and mail, to and from the UK and Eire and overflights between Europe and America. 104 pages. **£4.95**

#### GUIDE TO BROADCASTING STATIONS

**20th Edition 1989/90. Philip Darrington**  
Frequency and station data, receivers, antennas, Latin American DXing, reporting, computers in radio, etc. 240 pages. **£9.95**

#### GUIDE TO FACSIMILE STATIONS 10th Edition

**Joerg Klingenfuss**  
This manual is the basic reference book for everyone interested in FAX. Frequency, call sign, name of the station, ITU country/geographical symbol, technical parameters of the emission are all listed. All frequencies have been measured to the nearest 100Hz. 318 pages. **£12.00**

#### GUIDE TO FORMER UTILITY TRANSMISSIONS

**3rd Edition. Joerg Klingenfuss**  
Built on continuous monitoring of the radio spectrum from the sixties until the recent past. A useful summary of former activities of utility stations providing information in the classification and identification of radio signals. 126 pages. **£8.00**

#### GUIDE TO UTILITY STATIONS

**8th Edition. Joerg Klingenfuss**  
This book covers the complete short wave range from 3 to 30MHz plus the adjacent frequency bands from 0 to 150kHz and from 1.6 to 3MHz. It includes details on all types of utility stations including FAX and RTTY. There are 15802 entries in the frequency list and 3123 in the alphabetical call sign list plus press services and meteorological stations. 502 pages. **£19.00**

#### HF DECEANIC AIRBAND COMMUNICATIONS

**3rd Edition. Bill Laver**  
Aircraft channels by frequency and band, main ground radio stations, European R/T networks, North Atlantic control frequencies. 29 pages. **£3.50**

#### INTERNATIONAL RADIO STATIONS GUIDE (BP255)

Revised and updated in 1988, this book shows the site, country, frequency/wavelength and power of stations in Europe, the Near East and N. Africa, North and Latin America and the Caribbean, plus short wave stations worldwide. 128 pages. **£4.95**

#### MARINE UK RADIO FREQUENCY GUIDE

**Bill Laver**  
A complete guide to the UK s.w. and v.h.f. marine radio networks. Useful information, frequency listings and the World Marine Coastal Phone Stations. 62 pages. **£4.95**

#### NEWNES SHORT WAVE LISTENING HANDBOOK

**Joe Pritchard G1UQW**  
A technical guide for all short wave listeners. Covers construction and use of sets for the s.w.l. who wants to explore the bands up to 30MHz. 288 pages. **£12.95**

#### THE COMPLETE VHF/UHF FREQUENCY GUIDE

**Updated 1988**  
This book gives details of frequencies from 26-2250MHz with no gaps and who uses what. Recently updated, there are chapters on equipment requirements as well as antennas, etc. 88 pages. **£5.95**

#### THE INTERNATIONAL VHF FM GUIDE

**7th Edition. Julian Baldwin G3UHK and Kris Partridge G8AAU**  
The latest edition of this useful book gives concise details of repeaters and beacons worldwide plus coverage maps and further information on UK repeaters. 70 pages. **£6.95**

#### THE POCKET GUIDE TO RTTY AND FAX STATIONS

**Bill Laver**  
A handy reference book listing RTTY and FAX stations, together with modes and other essential information. The listing is in ascending frequency order, from 1.6 to 27.1MHz. 46 pages. **£2.95**

#### SHORT WAVE LISTENERS CONFIDENTIAL FREQUENCY LIST

**Bill Laver**  
Covering the services and transmission modes that can be heard on the bands between 1.635 and 29.7MHz. **£8.95**

#### VHF/UHF AIRBAND FREQUENCY GUIDE (Updated)

A complete guide to the airband frequencies including how to receive the signals, the frequencies and services, VOLMET and much more about the interesting subject of airband radio. 74 pages. **£5.95**

#### WORLD RADIO TV HANDBOOK 1990

Country-by-country listings of long, medium and short wave broadcast and TV stations. Receiver test reports. English language broadcasts. The s.w.l.'s bible. 576 pages. **£18.99**

### INTERFERENCE

#### INTERFERENCE HANDBOOK (USA)

**William R. Nelson WA6FGG**  
How to locate and cure r.f.i. for radio amateurs, CBers and TV and stereo owners. 253 pages. **£6.75**

#### RADIO FREQUENCY INTERFERENCE (USA)

What causes r.f.i. Are all r.f.i. problems difficult, expensive and time-consuming to cure? These questions and many more are answered in this book. 84 pages. **£4.30**

### AMATEUR RADIO

#### AMATEUR RADIO CALL BOOK (RSGB)

**Spring Edition**  
Now incorporates a 48-page section of useful information for amateur radio enthusiasts. 310 pages. **£7.70**

#### AMATEUR RADIO OPERATING MANUAL (RSGB)

A mine of information on just about every aspect of amateur operating. International call sign series holders, prefix lists, DXCC countries list, etc. 204 pages. **£6.16**

#### AMATEUR RADIO SATELLITES the first 25 years

**Arthur C. Gee G2UK**  
This souvenir publication mainly a pictorial account of the pattern of developments which have occurred over the last 25 years. 34 pages. **£2.25**

#### AN INTRODUCTION TO AMATEUR RADIO (BP257)

**I. D. Poole**  
This book gives the newcomer a comprehensive and easy to understand guide through amateur radio. Topics include operating procedures, jargon, propagation and setting up a station. 150 pages. **£3.50**

#### HINTS AND KINKS FOR THE RADIO AMATEUR

**Edited by Charles L. Hutchinson and David Newkirk**  
A collection of practical ideas gleaned from the pages of QST magazine. 152 pages. **O/S**

#### HOW TO PASS THE RADIO AMATEURS' EXAMINATION (RSGB)

**Clive Smith G4FZH and George Benbow G3HB**  
The background to multiple choice exams and how to study for them with sample RAE papers for practice plus maths revision. 88 pages. **£5.65**

#### PASSPORT TO AMATEUR RADIO

**Reprinted from PW 1981-1982**  
The famous series by G.W.J.G.A., used by thousands of successful RAE candidates



in their studies. Plus other useful articles for RAE students.  
96 pages. £1.50

## **PRACTICAL IDEAS FOR RADIO AMATEURS**

**Ian Poole G3YVX**  
Offers a wealth of hints, tips and general practical advice for all transmitting amateurs and short wave listeners. 120 pages. £5.95

## **RADIO AMATEUR'S GUIDE TO RADIO WAVE PROPAGATION**

**(HF Bands), F. C. Judd G2BCX**  
The how and why of the mechanism and variations of propagation in the h.f. bands. 144 pages. £8.95

## **THE 1990 ARRL HANDBOOK FOR THE RADIO AMATEUR**

This is the 66th edition of this very useful hardback reference book. Updated throughout it has several new sections covering oscilloscopes, spectrum analysers, digital frequency synthesis, phase-noise measurement and new constructional projects. 1200 pages. £15.95

## **\*THE ARRL OPERATING MANUAL**

Another very useful book from the ARRL. Although written for the American radio amateur, this book will also be of use and interest to the UK amateur. 684 pages. £12.95

## **THE ARRL SATELLITE ANTHOLOGY**

The best from the Amateur Satellite News column and articles out of 31 issues of QST have been gathered together in this book. The latest information on OSCARS 9 through 13 as well as the RS satellites is included. Operation on Phase 3 satellites (OSCAR 10 and 13) is covered in detail. 97 pages. £4.95

## **THE COMPLETE DX'er**

**Bob Locher W9KMI**  
Now back in print, this book covers equipment and operating techniques for the DX chaser, from beginner to advanced. 187 pages. £7.95

## **THE RAE MANUAL (RSGB)**

**G.L. Benbow G3HB**  
The latest edition of the standard aid to studying for the Radio Amateurs' Examination. Updated to cover the latest revisions to the syllabus. 132 pages. £5.65

## **THE RADIO AMATEUR'S DX GUIDE (USA)**

**15th Edition**  
The guide contains information not easily obtained elsewhere and is intended as an aid and quick reference for all radio amateurs interested in DX. 38 pages. £2.95

## **THE RADIO AMATEUR'S QUESTIONS & ANSWER REFERENCE MANUAL**

**4th Edition, R. E. G. Petri G8CCJ**  
This book has been compiled especially for students of the City and Guilds of London Institute RAE. It is structured with carefully selected multiple choice questions, to progress with any recognised course of instruction, although it is not intended as a text book. 280 pages. £7.95

## **VHF HANDBOOK FOR RADIO AMATEURS (USA)**

**H. S. Briar W9EGQ & W. I. Orr W6SAI**  
VHF/UHF propagation, including moonbounce and satellites, equipment and antennas. 335 pages. £7.95.

## **VHF/UHF MANUAL (RSGB)**

**G. R. Jessop G6J/P**  
Theory and practice of amateur radio reception and transmission, between 30MHz and 24GHz. 520 pages. £8.94

## **YOUR GATEWAY TO PACKET RADIO**

**Stan Horzepa WA1LOU**  
What is packet radio good for and what uses does it have for the 'average' amateur? What are protocols? Where, why, when? Lots of the most asked questions are answered in this useful book. It included details of networking and space communications using packet. 278 pages. £7.95

# **MAPS**

## **IARU LOCATOR MAP OF EUROPE**

**DARC**  
This multi-coloured, plastics laminated, map of Europe shows the AIRU ("Maidenhead") Locator System. Indispensable for the v.h.f. and u.h.f. DX'er. 692 x 872mm. £5.25

## **RADIO AMATEUR'S PREFIX MAP OF THE WORLD (USA)**

Showing prefixes and countries, plus listings by order of country and of prefix. 1014 x 711mm. £2.95

## **RADIO AMATEUR'S WORLD ATLAS (USA)**

Seventeen pages of maps, including the world-polar projection. Also includes the table of allocation of international call sign series. £3.50

# **DATA REFERENCE**

## **DIGITAL IC EQUIVALENTS AND PIN CONNECTIONS (BP140)**

**A. Michaels**  
Equivalents and pin connections of a popular selection of European, American and Japanese digital i.c.s. 256 pages. £5.95

## **INTERNATIONAL DIODE EQUIVALENTS GUIDE (BP108)**

**A. Michaels**  
Possible substitutes for a large selection of many different types of semiconductor diodes. 144 pages. 0/P.

## **INTERNATIONAL TRANSISTOR EQUIVALENTS GUIDE (BP85)**

**A. Michaels**  
Possible substitutes for a popular selection of European, American and Japanese transistors. 320 pages. £3.50

## **LINEAR IC EQUIVALENTS AND PIN CONNECTIONS (BP141)**

**A. Michaels**  
Equivalents and pin connections of a popular selection of European, American and Japanese linear i.c.s. 320 pages. 0/P

## **NEWNES AUDIO & HI-FI ENGINEER'S POCKET BOOK**

**Vivian Capel**  
This is a concise collection of practical and relevant data for anyone working on sound systems. The topics covered include microphones, gramophones, CDs to name a few. 190 pages. Hardback. £9.95

## **NEWNES COMPUTER ENGINEER'S POCKET BOOK**

This is an invaluable compendium of facts, figures, circuits and data and is indispensable to the designer, student, service engineer and all those interested in computer and microprocessor systems. 203 pages. Hardback. £9.95

## **NEWNES ELECTRONICS POCKET BOOK**

**5th Edition**  
Presenting all aspects of electronics in a readable and largely non-mathematical form for both the enthusiast and the professional engineer. 315 pages. Hardback. £8.95

## **NEWNES RADIO AND ELECTRONICS ENGINEER'S POCKET BOOK**

**18th Edition, Keith Brindley**  
Useful data covering math, abbreviations, codes, symbols, frequency bands/allocations, UK broadcasting stations, semi-conductors, components, etc. 325 pages. Hardback. £9.95

## **NEWNES TELEVISION AND VIDEO ENGINEER'S POCKET BOOK**

**Eugene Trundle**  
This is a valuable reference source for practitioners in "entertainment" electronic

equipment. It covers TV reception from v.h.f. to s.h.f. display tubes, colour camera technology, video recorder and video disc equipment, video text and hi-fi sound. 323 pages. Hardback. 0/P

## **POWER SELECTOR GUIDE (BP235)**

**J. C. J. Van de Ven**  
This guide has the information on all kinds of power devices in useful categories (other than the usual alpha numeric sort) such as voltage and power properties making selection of replacements easier. 180 pages. £4.95

## **RSGB RADIO DATA REFERENCE BOOK**

**G. R. Jessop G6J/P**  
The 5th Edition of an essential book for the radio amateur's or experimenter's workbench. 244 pages. Hardback. 0/P

## **TRANSISTOR SELECTOR GUIDE (BP234)**

**J. C. J. Van de Ven**  
This guide has the information on all kinds of transistors in useful categories (other than the usual alpha numeric sort) such as voltage and power properties making selection of replacements easier. 192 pages. 0/P

# **FAULT FINDING**

## **ARE THE VOLTAGES CORRECT?**

**Reprinted from PW 1982-1983**  
How to use a multimeter to fault-find on electronic and radio equipment, from simple resistive dividers through circuits using diodes, transistors, i.c.s and valves. 44 pages. £1.50

## **GETTING THE MOST FROM YOUR MULTIMETER (BP239)**

**R. A. Penfold**  
This book is primarily aimed at beginners. It covers both analogue and digital multimeters and their respective limitations. All kinds of testing is explained too. No previous knowledge is required or assumed. 102 pages. £2.95

## **MORE ADVANCED USES OF THE MULTIMETER BP265**

**R.A. Penfold**  
This book is primarily intended as a follow-up to BP239, Getting the most from your Multimeter. By using the techniques described in this book you can test and analyse the performance of a range of components with just a multimeter (plus a very few inexpensive components in some cases). The simple add-ons described extend the capabilities of a multimeter to make it even more useful. 85 pages. £2.95.

## **OSCILLOSCOPIES, HOW TO USE THEM, HOW THEY WORK 3rd Edition**

**Ian Hickman**  
This book describes oscilloscopes ranging from basic to advanced models and the accessories to go with them. £12.95

## **PRACTICAL HANDBOOK OF VALVE RADIO REPAIR**

**Chas E. Miller**  
The definitive work on repairing and restoring valued broadcast receivers dating from the 1930s to the 60s. Appendices giving intermediate frequencies, valve characteristic data and base connections. 230 pages. Hardback. £20.00

## **SERVICING RADIO, HI-FI AND TV EQUIPMENT**

**Gordon J. King**  
A very practical book looking at semiconductor characteristics, d.c. and signal tests, fault-finding techniques for audio, video, r.f. and oscillator stages and their application to transistor radios and hi-fi. 205 pages. 0/P

## **TRANSISTOR RADIO FAULT FINDING CHART (BP70)**

**C. E. Miller**  
Used properly, should enable most common faults to be traced reasonably quickly. Selecting the appropriate fault description at the head of the chart, the reader is led through a sequence of suggested checks until the fault is cleared. 635 x 455mm (approx). £0.95

# **CONSTRUCTION**

## **HOW TO DESIGN AND MAKE YOUR OWN P.C.B.s (BP121)**

**R. A. Penfold**  
Designing or copying printed circuit board designs from magazines, including photographic methods. 80 pages. £2.50

## **INTRODUCING QRP**

**Collected articles from PW 1983-1985**  
An introduction to low-power transmission, including constructional details of designs by Rev. George Dobos G3RLW for transmitters and transceivers from Top Band to 14MHz, and test equipment by Tony Smith G4FAL. 64 pages. £1.50

## **MORE ADVANCED POWER SUPPLY PROJECTS (BP192)**

**R. A. Penfold**  
The practical and theoretical aspects of the circuits are covered in some detail. Topics include switched mode power supplies, precision regulators, dual tracking regulators and computer controlled power supplies, etc. 92 pages. £2.95

## **POWER SUPPLY PROJECTS (BP76)**

**R. A. Penfold**  
This book gives a number of power supply designs including simple unregulated types, fixed voltage regulated types and variable voltage stabilised designs. 91 pages. £2.50

## **PRACTICAL POWER SUPPLIES**

**Collected articles from PW 1978-1985**  
Characteristics of batteries, transformers, rectifiers, fuses and heatsinks, plus designs for a variety of mains driven power supplies, including the "PW" "Marchwood" giving a fully stabilised and protected 12V 30A d.c. 48 pages. £1.25

## **QRP NOTEBOOK**

**Doug DeMaw W1FB**  
This book deals with the building and operating of a successful QRP station. Lots of advice is given by the author who has spent years as an ardent QRP'er. All the text is easy-to-read and the drawings large and clear. 77 pages. £4.95

## **TEST EQUIPMENT CONSTRUCTION**

**R.A.Penfold**  
Describes, in detail, how to construct some simple and inexpensive, but extremely useful, pieces of test equipment. 104 pages. £2.95

## **50 (FET) FIELD EFFECT TRANSISTOR PROJECTS**

**F.G.Rayer**  
50 circuits for the s.w.l., radio amateur, experimenter or audio enthusiast using i.e.t.s. 104 pages. £2.95

# **ANTENNAS (AERIALS)**

## **AERIAL PROJECTS (BP105)**

Practical designs including active, loop and ferrite antennas plus accessory units. 96 pages. £2.50

## **ALL ABOUT CUBICAL QUAD ANTENNAS (USA)**

**W. I. Orr W6SAI & S. D. Cowan W2LX**  
Theory, design, construction, adjustment and operation of quads. Quads vs. Yagis. Gain figures. 109 pages. £5.50

## **ALL ABOUT VERTICAL ANTENNAS (USA)**

**W. I. Orr W6SAI & S. D. Cowan W2LX**  
Theory, design, construction, operation, the secrets of making vertical work. 191 pages. £7.50

## **AN INTRODUCTION TO ANTENNA THEORY (BP198)**

**H. C. Wright**  
This book deals with the basic concepts relevant to receiving and transmitting antennas. Lots of diagrams reduce the amount of mathematics involved. 86 pages. £2.95

## **ANTENNA IMPEDANCE MATCHING**

**Wilfred N. Caron**  
Proper impedance matching of an antenna to a transmission line is of concern to antenna engineers and to every radio amateur. A properly matched antenna as the termination for a line minimises feed-line losses. Power can be fed to such a line without the need for a matching network at the line input. There is no mystique involved in designing even the most complex multi-element networks for broadband coverage. Logical step-by-step procedure is followed in this book to help the radio amateur with this task. 192 pages. £11.95

## **BEAM ANTENNA HANDBOOK (USA)**

**W. I. Orr W6SAI & S. D. Cowan W2LX**  
Design, construction, adjustment and installation of h.f. beam antennas. 198 pages. 0/P

## **HF ANTENNAS FOR ALL LOCATIONS (RSGB)**

**L. A. Moxon G6XN**  
Taking a new look at how h.f. antennas work, and putting theory into practice. 260 pages. £5.19

## **\*NOVICE ANTENNA NOTEBOOK**

**Doug DeMaw W1FB**  
Another book from the pen of W1FB, this time offering "new ideas for beginning hams". All the drawings are large and clear and each chapter ends with a glossary of terms. 130 pages. £5.95

## **OUT OF THIN AIR**

**Collected Antenna Articles from PW 1977-1980**  
Including such favourites as the ZL Special and 2BCX 16-element beams for 2m, and the famous "Slim Jim", designed by Fred Judd G2BCX. Also features systems for "Top Band, medium-wave/long wave loop designs and a v.h.f. direction finding loop. Plus items on propagation, accessories and antenna design. 80 pages. £1.80

## **PRACTICAL WIRE ANTENNAS - Effective HF Oesigins for the Radio Amateur, John D Heys G3BQC**

Wire antennas offer one of the most cost-effective ways to put out a good signal on the h.f. bands and this practical guide to their construction has something to interest every amateur on a budget. 100 pages. £7.53.

## **SIMPLE, LOW-COST WIRE ANTENNAS FOR RADIO AMATEURS (USA)**

**W. I. Orr W6SAI & S. D. Cowan W2LX**  
Efficient antennas for Top Band to 2m, including "invisible" antennas for difficult station locations. 191 pages. £6.75

## **THE ARRL ANTENNA BOOK (USA) 15th Edition**

A station is only as effective as its antenna system. This book covers propagation, practical constructional details of almost every type of antenna, test equipment and formulas and programs for beam heading calculations. £12.95

## **THE ARRL ANTENNA COMPENDIUM (USA)**

**Volume One**  
Fascinating and hitherto unpublished material. Among the topics discussed are quads and loops, loop periodic arrays, beam and multi-band antennas, verticals and reduced size antennas. 175 pages. £7.50

## **WIRES & WAVES**

**Collected Antenna Articles from PW 1980-1984**  
Antenna and propagation theory, including NBS Yagi design data. Practical designs for antennas from medium waves to microwaves, plus accessories such as a t.u.s. s.w.r., and power meters and a noise bridge. Dealing with TVI. 160 pages. £3.00

## **W1FB'S ANTENNA NOTEBOOK**

**Doug DeMaw W1FB**  
This book provides lots of designs, in simple and easy to read terms, for simple wire and tubing antennas. All drawings are large and clear making construction much easier. 124 pages. £5.95

## **25 SIMPLE AMATEUR BAND AERIALS (BP125)**

**E. M. Noll**  
How to build 25 simple and inexpensive aerials, from a simple dipole through beam and triangle designs to a mini-thombic. Dimensions for specific spot frequencies including the WARC bands. 80 pages. £1.95

## **25 SIMPLE INDOOR AND WINDOW AERIALS (BP136)**

**E. M. Noll**  
Designs for people who live in flats or have no gardens, etc., giving surprisingly good results considering their limited dimensions. 64 pages. £1.75

## **25 SIMPLE SHORT WAVE BROADCAST BAND AERIALS (BP132)**

**E. M. Noll**  
Designs for 25 different aerials, from a simple dipole through helical designs to a multi-band umbrella. 80 pages. £1.95

## **25 SIMPLE TROPICAL AND MW BAND AERIALS (BP145)**

**E. M. Noll**  
Simple and inexpensive aerials for the broadcast bands from medium wave to 49m. 64 pages. £1.75

## **THE RADIO AMATEUR ANTENNA HANDBOOK**

**William I. Orr W6SAI & Stuart D. Cowan W2LX**  
Yagi, quad, quagi, 1-b, vertical, horizontal and "sloper" antennas are all covered. Also towers, grounds and rotators. 190 pages. £6.75

# **COMPUTING**

## **AN INTRODUCTION TO COMPUTER COMMUNICATIONS (BP177)**

**R. A. Penfold**  
Details of various types of modem and their applications, plus how to interconnect computers, modems and the telephone system. Also networking systems and RTTY. 96 pages. £2.95

## **AN INTRODUCTION TO COMPUTER PERIPHERALS (BP170)**

**J. W. Penfold**  
Covers a wide range of computer peripherals such as monitors, printers, disk drives, cassette recorders, modems, etc., explaining what they are, how to use them and the various types of standards. 80 pages. £2.50

## **MICROPROCESSING SYSTEMS AND CIRCUITS (BP77)**

**Elements of Electronics Book 4**  
**F. A. Wilson**  
A comprehensive guide to the elements of microprocessing systems, which are becoming ever more involved in radio systems and equipment. 256 pages. 0/P

# **MORSE**

## **INTRODUCING MORSE**

**Collected Articles from PW 1982-1985**  
Ways of learning the Morse Code, followed by constructional details of a variety of keys including Iambic, Triambic, and an Electronic Bug with a 528-bit memory. 48 pages. £1.25

## **THE MORSE CODE FOR RADIO AMATEURS (RSGB)**

**Margaret Mills G3ACC**  
A guide to learning to send and receive Morse code signals up to the 12 w.p.m. required for the radio amateur aspiring to a Class A licence having passed the RAE. 19 pages. £2.88

## **THE SECRET OF LEARNING MORSE CODE**

**Mark Francis**  
Designed to make you proficient in Morse code in the shortest possible time, this book points out many of the pitfalls that beset the student. 87 pages. £4.95





# Yaesu has serious listeners for the serious listener

Yaesu's serious about giving you better ways to tune in the world around you.

And whether it's for local action or worldwide DX, you'll find our VHF/UHF receivers are the superior match for all your listening needs.

**The FRG-9600. A premium VHF/UHF scanning communications receiver.** The 9600 is no typical scanner. And it's easy to see why.

You won't miss any local action with continuous coverage from 60 to 905MHz.

You have more operating modes to listen in on: upper or lower sideband, CW, AM wide or narrow, and FM wide or narrow.

You can even watch television programmes by plugging in a video monitor into the optional video output. (NTSC System).

Scan in steps of 5, 10, 12½, 25 and 100kHz. Store any frequency and related operating mode into any of the 99 memories. Scan the

memories. Or in between them. Or simply "dial up" any frequency with the frequency entry pad.

Plus there's more, including a 24-hour clock, multiplexed output, fluorescent readout, signal strength graph, and an optional PA4C, AC power adaptor.

Extend the coverage further with the optional FC965DX 0.15-30MHz and FC1300 800-1300MHz external converters.

**The FRG-8800 HF communications receiver. A better way to listen to the world.** If you want a complete communications package, the FRG-8800 is just right for you.

You get continuous worldwide coverage from 150kHz to 30MHz. And local coverage from 118 to 174MHz with an optional VHF converter.

Listen in on any mode: upper and lower sideband, CW, AM wide or narrow, and FM.

Store frequencies and operating modes into any of the twelve channels for instant recall.

Scan the airwaves with a number of programmable scanning functions.

Plus you get keyboard frequency entry. An LCD display for easy readout. A SINPO signal graph. Computer interface capability for advanced listening functions. Two 24-hour clocks. Recording functions. And much more to make your listening station complete.

**Listen in.** When you want more from your VHF/UHF or HF receivers, just look to Yaesu. We take your listening seriously.

## YAESU

*South Midlands Communications Ltd*  
*S.M. House, School Close,*  
*Chandlers Ford Industrial Estate,*  
*Eastleigh, Hants SO5 3BY*  
*Tel: (0703) 255111*  
**UK Sole Distributor**



Dealer inquiries invited.

Prices and specifications subject to change without notice.  
 FRG-9600 SSB coverage: 60 to 460 MHz.



# ICOM

**ICOM are proud to introduce the IC-R72 Communications Base Receiver to complement the IC-R100 Mobile and IC-R1 Handheld receivers giving the enthusiastic listener a full choice.**



### Features:

- Direct Frequency entry
- 99 Memory Channels
- Built-in clock and timer
- AC/DC operation
- Noise Blanker
- Pre-amp and Attenuator
- ICOM's DDS system (direct digital synthesiser)

### IC-R72 Communications Receiver

ICOM's communication receivers have a reputation for reliability and quality. Building on this reputation the IC-R72 HF receiver is one of a new line of wideband receivers to satisfy listeners everywhere.

This compact receiver has continuous coverage from 100kHz – 30MHz, in SSB, AM and CW modes. An optional UI-8 adds FM reception. The easy to operate IC-R72 is superb for beginners or experienced DX'ers alike and is equipped with a variety of functions.

The IC-R72 boasts a unique internal storage battery which provides approx. one hours operation when an external supply is not available, making it ideal for portable use or during power failures. The IC-R72 joins ICOM's current line of quality receivers. For a free brochure on this or any other ICOM Amateur Radio product contact your local authorised ICOM dealer or ICOM (UK) Ltd.

### Icom (UK) Ltd

Dept. SW, Sea Street, Herne Bay, Kent CT6 8LD. Tel: 0227 741741. Fax: 0227 360155.

**Visa & Mastercards:** Telephone orders taken by mail order, instant credit & interest-free HP. Despatch on same day whenever possible.

